

# SUPER-PACK®

**CARTONCINI CALIBRATI DI ALTA QUALITÀ E PRECISIONE - I PRIMI CARTONCINI "CERTIFICATI" AL MONDO**  
**HIGH QUALITY AND PRECISION UNDERPACKING PAPER - THE FIRST CERTIFIED UNDERPACKING PAPERS IN THE WORLD**  
**ALZAS CALIBRADAS DE ALTA CALIDAD Y PRECISION - LOS PRIMEROS PAPELES CALIBRADOS "CERTIFICADOS" EN EL MUNDO**



Speciale trattamento repellenza al solvente  
*Special solvent - repellent treatment*  
 Tratamiento especial repelente al solvente



**MISURE STANDARD "UFFICIALI"**  
**"OFFICIAL" STANDARD SIZES**  
**MEDIDAS ESTANDAR "OFICIALES"**

TOK T - OFFSET	370 x 270
GTO 46	448 x 350
QUICKMASTER 46	485 x 340
GTO 52 / PRINTMASTER 52	510 x 360
SPEEDMASTER 52 / SX 52	532 x 377
KOR 57	568 x 460
KORA	575 x 500
KORD 62	622 x 500
KORD 64	648 x 510
MO - SORK	650 x 530
KORS 72	722 x 570
SPEEDMASTER 72/SORM	730 x 595
SPEEDMASTER 74 - OLD MODEL / SX 74	750 x 550
SPEEDMASTER 75 XL - SPEEDMASTER 74	750 x 620
SPEEDMASTER 74 - CD	760 x 620
SORD	892 x 670
SPEEDMASTER 102 / SX 102 / SORS 102 ROTASPEED	1030 x 735
SPEEDMASTER 102 CD / 102 CX	1030 x 795
SPEEDMASTER 105 XL / 106 XL	1054 x 765
SPEEDMASTER 145 XL	1460 x 1070
SPEEDMASTER 162 XL	1630 x 1220



**LA PIÙ VASTA GAMMA DI CARTONCINI CALIBRATI AL MONDO!**  
**THE LARGEST RANGE OF CALIBRATED PAPER IN THE WORLD!**  
**¡LA MAYOR GAMA DE TARJETAS CALIBRADAS DEL MUNDO!**



**SEVERE VERIFICHE PER IL CONTROLLO DELLO STANDARD QUALITATIVO  
PRECISE MEASUREMENTS ARE MADE TO CHECK THE QUALITY STANDARD  
SEVERAS COMPROBACIONES PARA EL CONTROL DE CALIDAD**

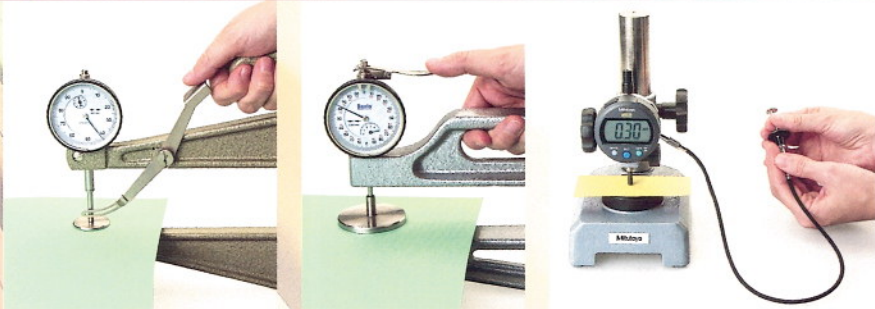

SPessori  
DISPONIBILI  
THICKNESSES  
AVAILABLE  
ESPORES  
DISPONIBLES

mm	my	inch	
0,05	50	002"	ROSA / PINK / ROSA
0,075	75	003"	VERDE ACQUA / AQUAMARINE / AGUAMARINA
0,10	100	004"	AVORIO / IVORY / MARFIL
0,125	125	005"	SALMONE / SALMON / SALMÓN
0,15	150	006"	MARRONE / BROWN / MARRON
0,175	175	007"	CORALLO / CORAL / CORAL
0,20	200	008"	VERDE / GREEN / VERDE
0,25	250	010"	ARANCIO / ORANGE / NARANJA
0,30	300	012"	GIALLO / YELLOW / AMARILLO
0,35	350	014"	PISTACCHIO / PISTACHIO / PISTACHO
0,40	400	016"	AZZURRO / LIGHT BLUE / AZUL
0,50	500	020"	GRIGIO / GREY / GRIS

**I CARTONCINI CALIBRATI "SUPER PACK"  
VENGONO FORNITI STESI IN BOX DI CARTONE  
CON RINFORZI LATERALI IN LEGNO**

**THE "SUPER PACK" UNDERPACKING PAPERS  
ARE SUPPLIED PACKED FLAT IN CARDBOARD  
BOXES WITH LATERAL WOODEN SUPPORTS**

**LOS PAPELES CALIBRADOS "SUPER PACK"  
SE SUMINISTRAN PLANOS, EN CAJAS DE CARTON  
CON REFUERZOS LATERALES DE MADERA**

**SPESORE SPECIFICO PER OTTENERE UN "PACK"  
PRECISO NELLE MACCHINE HEIDELBERG  
SPECIFIC THICKNESS TO OBTAIN A PRECISE "PACK"  
IN HEIDELBERG PRESSES**

**ESPEJOR ESPECÍFICO PARA OBTENER UN "PACK"  
PRECISO EN MÁQUINAS HEIDELBERG**

**LO TROVI SOLO DA NOI ...  
YOU CAN ONLY GET IT FROM US ...  
PUEDES ENCONTRARLO SOLO CON NOSOTROS**

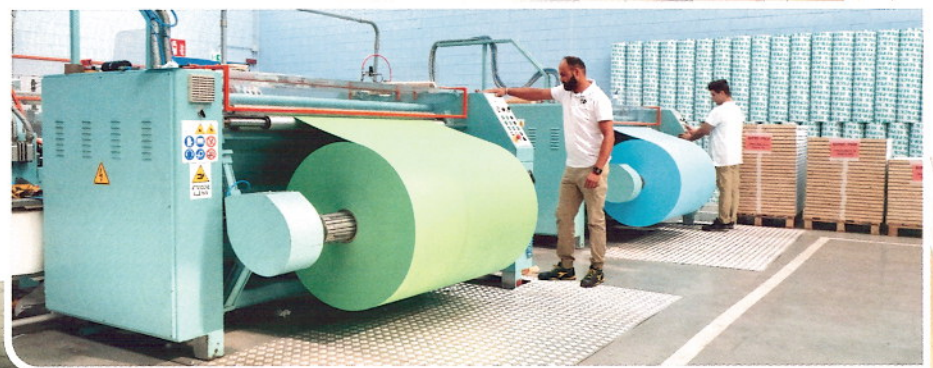

**N.T.L.T.®**  
**No Thickness Loss Technology**

**PATENTED**  
**HIGHLANDER**  
**PACK INFINITY®**  
**STRUCTURAL UNDERPACKING**  
**"INDESTRUCTIBLE"**



**ADHESIVE  
VERSION  
NOW  
AVAILABLE**



**THE ONLY EXISTING  
NON-DEFORMABLE STRUCTURAL  
UNDERPACKING IN THE WORLD**

# UNDER THE PRINTING BLANKET IN ORDER TO OBTAIN THE "PERFECT PACK"

**N.T.L.T.®**

## **No Thickness Loss Technology** (NON-DEFORMABLE STRUCTURAL UNDERPACKING)

**FOR A VERY HIGH PRINT QUALITY**

**THE PRECISION OF THE "PACK" IS VERY IMPORTANT ... BUT OFTEN UNDERESTIMATED !**

**JUST APPLY THESE FOUR RULES  
TO GET A "PERFECT PACK"**

- 1 CAREFULLY CONSULT THE MACHINE MANUAL**  
IN ORDER TO IDENTIFY THE EXACT THICKNESS  
OF THE "PACK" TO USE.

### **"PACK" TRADITIONAL METHOD**

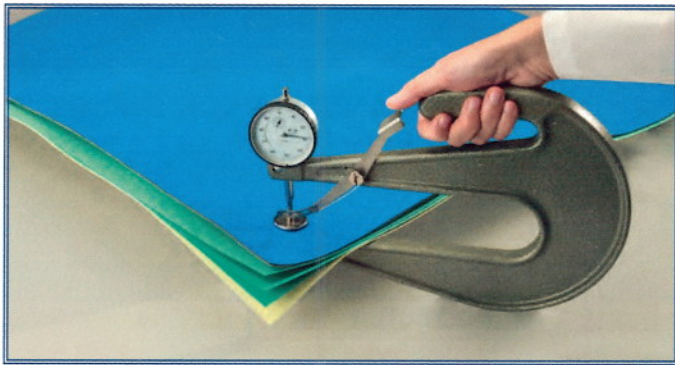

- 3 DO NOT INCREASE THE THICKNESS  
OF THE "PACK" !**  
AN EXCESSIVE THICKNESS OF THE "PACK"  
WILL RESULT IN A SIGNIFICANT REDUCTION OF  
THE PRINT QUALITY AND THE BLANKET WILL BE  
MARKED AND WILL KEEP THE TRACES OF  
THE PREVIOUS PRINT JOB .

### **"PACK" WITH HIGHLANDER INFINITY®**

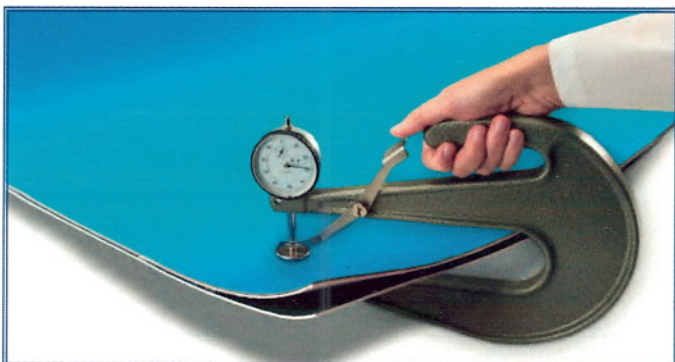

- 2 RESPECT PERFECTLY  
THE THICKNESS OF THE "PACK"**  
MEASURING WITH A MICROMETRE EACH  
INDIVIDUAL COMPONENT OF THE UNDERPACKING USED.

**INCORRECT PACK**  
Increased pack thickness

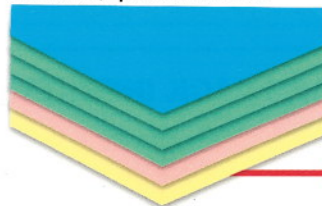

PRINT RESULT

**CORRECT PACK**  
Exact pack thickness as  
indicated in the machine manual

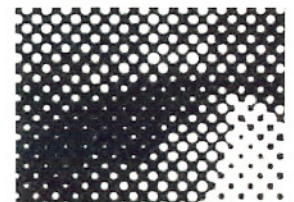
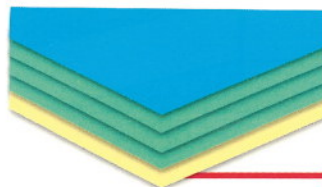

PRINT RESULT

- 4 HOW TO OBTAIN THE "PERFECT PACK":**  
THE USE OF OUR PRINTING BLANKETS PRODUCED  
WITH **N.T.L.T. (No Thickness Loss Techno-**  
**logy)** WITH THE STRUCTURAL UNDERPACKING

**HIGHLANDER PACK INFINITY®** guarantees precisely the exact thickness of the "PACK" as indicated in the press manual and the maintaining of the thickness for a large number of production runs.

# PATENTED HIGHLANDER PACK INFINITY®

**THE ONLY STRUCTURAL UNDERPACKING  
FOR PRINTING BLANKETS  
WITH HIGH DIMENSIONAL STABILITY  
AND A GROUND SURFACE  
(KEEPS THE THICKNESS STABLE)**

## HIGHLANDER

is an innovative non-deformable underpacking that can be used under any printing blanket with the purpose of obtaining the absolutely **precise** thickness (Pack) in conformity with the indications in all the machine manufacturers' manuals.

The **Precision** and the **Maintaining** of the thickness are the most important characteristics of **HIGHLANDER** which differentiate it from any other similar product in the world and which guarantee a superior quality of dot printing.

## HIGHLANDER PACK INFINITY® NON-ADHESIVE

is produced in the following thicknesses:

- 0.40mm
- 0.45mm
- 0.50mm
- 0.55mm
- 0.60mm

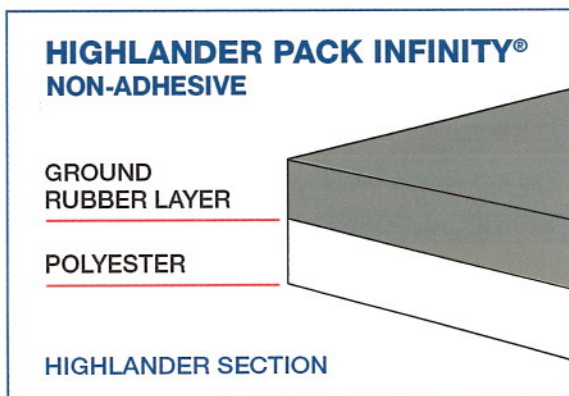

- 0.65mm
- 0.70mm
- 0.75mm
- 0.80mm
- 0.85mm
- 0.90mm
- 0.95mm
- 1.00mm
- 1.10mm
- 1.15mm
- 1.30mm
- 1.35mm
- 1.40mm
- 1.45mm
- 1.50mm

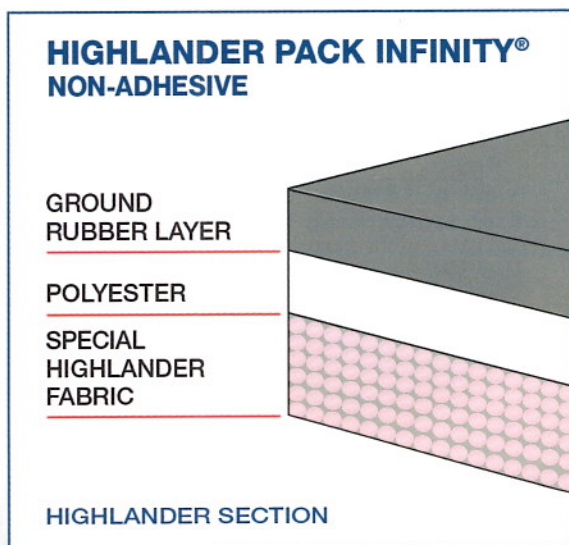

## HIGHLANDER PACK INFINITY® NON-ADHESIVE

is supplied in cut sheets and in rolls.

**HIGHLANDER** is manufactured using a special production system which guarantees a real dimensional stability superior to all other materials present in the market.

The dimensional stability of **HIGHLANDER** guarantees the complete maintaining of the thickness of all the Pack, ensuring a longer working life than any other system in use today.

**HIGHLANDER** is the only underpacking manufactured with the surface totally ground, thus guaranteeing a greater durability that is not comparable with any other known system.

## HIGHLANDER PACK INFINITY®

is made using a special fabric structure coupled with a layer of polyester and a layer of rubber.

**NEW!!**

## HIGHLANDER PACK INFINITY®

**ADHESIVE VERSION NOW AVAILABLE!**

## HIGHLANDER PACK INFINITY® ADHESIVE

is produced in the following thicknesses:

- 0.65mm
- 0.70mm
- 0.75mm
- 0.80mm
- 0.85mm

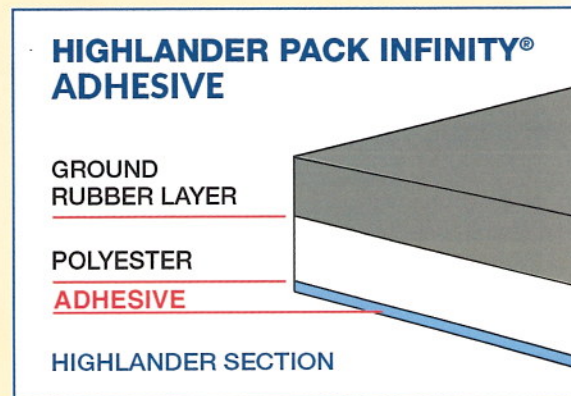

- 0.90mm
- 0.95mm
- 1.00mm
- 1.05mm
- 1.10mm
- 1.15mm
- 1.20mm
- 1.25mm
- 1.30mm
- 1.35mm
- 1.40mm
- 1.45mm
- 1.50mm



## HIGHLANDER PACK INFINITY® ADHESIVE

is supplied in cut sheets.



**RACCOGLI GRUMI  
HICKEY REMOVERS  
QUITAMOTAS**

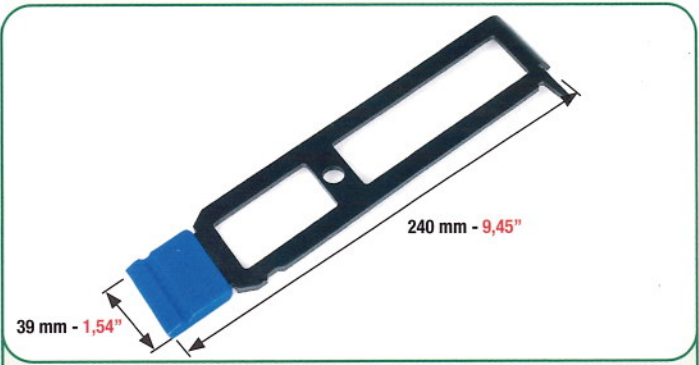

**RACCOGLI GRUMI COMPLETO PER:  
COMPLETE HICKEY REMOVER FOR:  
QUITAMOTAS COMPLETO PARA:**

**HEIDELBERG SPEEDMASTER 52**

CODICE - CODE - CÓDIGO

**3796**

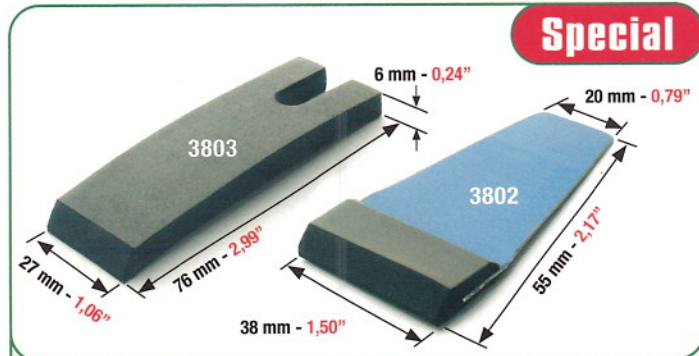

**RACCOGLI GRUMI PER:  
HICKEY REMOVER FOR:  
QUITAMOTAS PARA:**

**HEIDELBERG MO**

ORDINE MINIMO 5 PEZZI  
MINIMUM ORDER 5 PCS  
PEDIDO MÍNIMO 5 PIEZAS

CODICE - CODE - CÓDIGO

**3803  
3802**

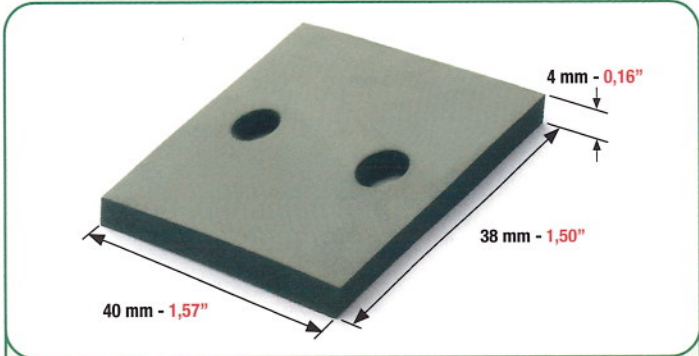

**RICAMBIO IN GOMMA PER RACCOGLI GRUMI:  
RUBBER HICKEY REMOVER REPLACEMENT FOR:  
RECAMBIO DE GOMA PARA QUITAMOTAS PARA:**

**HEIDELBERG MO/SORM/SORD/SORS**

ORDINE MINIMO 5 PEZZI  
MINIMUM ORDER 5 PCS  
PEDIDO MÍNIMO 5 PIEZAS

CODICE - CODE - CÓDIGO

**3801**

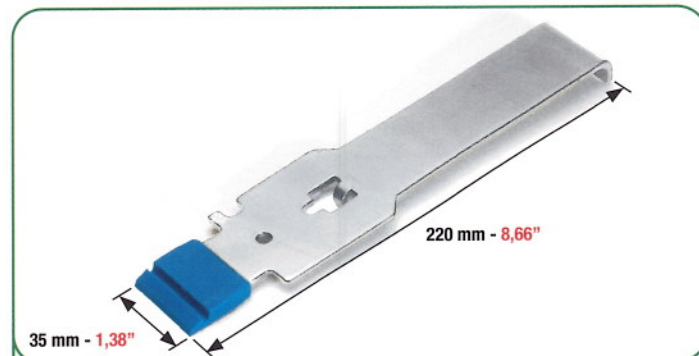

**RACCOGLI GRUMI COMPLETO PER:  
COMPLETE HICKEY REMOVER FOR:  
QUITAMOTAS COMPLETO PARA:**

**HEIDELBERG SPEEDMASTER 74**

CODICE - CODE - CÓDIGO

**3806**



**RACCOGLI GRUMI COMPLETO PER:  
COMPLETE HICKEY REMOVER FOR:  
QUITAMOTAS COMPLETO PARA:**

**HEIDELBERG SPEEDMASTER 74CD/75XL**

CODICE - CODE - CÓDIGO

**3806-A**



RACCOGLI GRUMI COMPLETO PER:  
COMPLETE HICKEY REMOVER FOR:  
QUITAMOTAS COMPLETO PARA:

**HEIDELBERG SORM/SORD/SORS**

CODICE - CODE - CÓDIGO

**3797**



RACCOGLI GRUMI IN GOMMA PER:  
RUBBER HICKEY REMOVER FOR:  
QUITAMOTAS DE GOMA PARA:

**HEIDELBERG SORD-Z**

CODICE - CODE - CÓDIGO

ORDINE MINIMO 5 PEZZI  
MINIMUM ORDER 5 PCS  
PEDIDO MÍNIMO 5 PIEZAS

**3804**

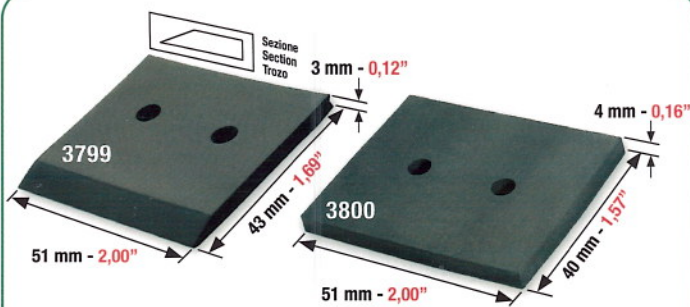

RICAMBIO IN GOMMA PER RACCOGLI GRUMI PER:  
RUBBER HICKEY REMOVER REPLACEMENT FOR:  
RECAMBIO DE GOMA PARA QUITAMOTAS PARA:

**HEIDELBERG SPEEDMASTER 102-SORS/102CD**

CODICE - CODE - CÓDIGO

ORDINE MINIMO 5 PEZZI  
MINIMUM ORDER 5 PCS  
PEDIDO MÍNIMO 5 PIEZAS

**3799**  
**3800**



RACCOGLI GRUMI COMPLETO PER:  
COMPLETE HICKEY REMOVER FOR:  
QUITAMOTAS COMPLETO PARA:

**HEIDELBERG SPEEDMASTER 102/102CD**

CODICE - CODE - CÓDIGO

**3798**



RACCOGLI GRUMI COMPLETO PER:  
COMPLETE HICKEY REMOVER FOR:  
QUITAMOTAS COMPLETO PARA:

**HEIDELBERG SPEEDMASTER 105XL**

CODICE - CODE - CÓDIGO

**3795**

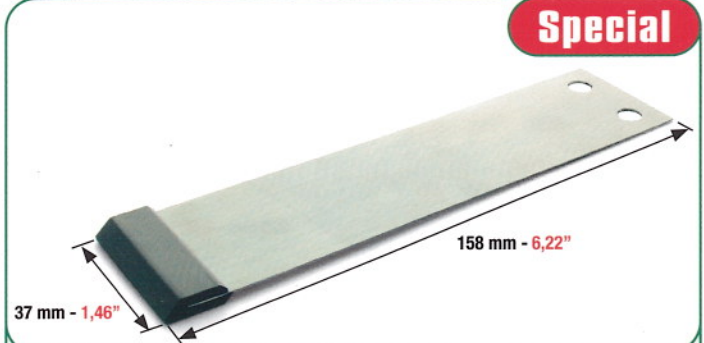

RACCOGLI GRUMI PER:  
HICKEY REMOVER FOR:  
QUITAMOTAS PARA:

**HEIDELBERG**

CODICE - CODE - CÓDIGO

ORDINE MINIMO 5 PEZZI  
MINIMUM ORDER 5 PCS  
PEDIDO MÍNIMO 5 PIEZAS

**3805**



GUARNIZIONE TRA GRUPPI STAMPA KP.L.M.V.  
SEAL BETWEEN PRINTING UNITS KP.L.M.V.  
GUARNIZIONE ENTRE UNIDADES DE IMPRESION KP.L.M.V.

**HEIDELBERG SM 102 CD**

CONFEZIONE DA 2 PEZZI (DX + SX)  
PACKET OF 2 PCS (RIGHT + LEFT)  
CONFECCION DE 2 PIEZAS (DERECHA + IZQUIERDA)

CODICE - CODE - CÓDIGO

**5148**

1000 mm

80mm



# GRIPPERS AND GRIPPER PADS

PINZE PER CILINDRI

PINZAS PARA CILINDROS



**NEW PRODUCTS 2021**

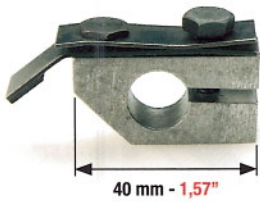

PINZA COMPLETA DI SUPPORTO PER:  
COMPLETE GRIPPER FOR:  
PINZA COMPLETA CON SOPORTE PARA:

**HEIDELBERG GTO 46/GTO 52/KORD 62/KORD 64**

COMPATIBLE WITH OEM PART

CODICE - CODE - CÓDIGO

...

**4801**

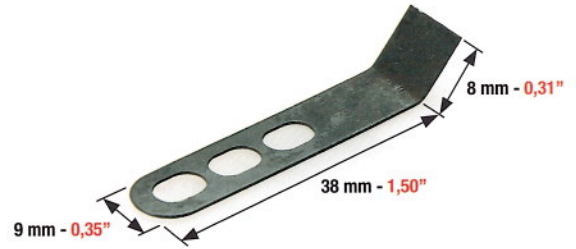

PINZA METTIFOGLIO PER MACCHINA TIPOGRAFICA PER:  
FEEDER GRIPPER FOR LETTERPRESS MACHINE FOR:  
PINZA DEL MARCADOR PARA MAQUINA TIPOGRÁFICA PARA:

**HEIDELBERG CYLINDER SBG**

ORDINE MINIMO 5 PEZZI  
MINIMUM ORDER 5 PCS  
PEDIDO MÍNIMO 5 PIEZAS

COMPATIBLE WITH OEM PART

CODICE - CODE - CÓDIGO

...

**4821**



WITH AIR HOLE

PINZA PER METTIFOGLIO CON PUNTALE IN GOMMA PER:  
FEEDER GRIPPER WITH RUBBER PAD FOR:  
PINZA PARA MARCADOR CON GOMA PARA:

**HEIDELBERG GTO / MO / KORD**

ORDINE MINIMO 5 PEZZI  
MINIMUM ORDER 5 PCS  
PEDIDO MÍNIMO 5 PIEZAS

COMPATIBLE WITH OEM PART

CODICE - CODE - CÓDIGO

**43.020.035F**

**4790**

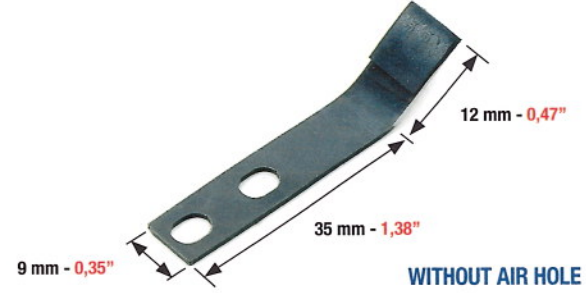

WITHOUT AIR HOLE

PINZA PER METTIFOGLIO CON PUNTALE IN GOMMA PER:  
FEEDER GRIPPER WITH RUBBER PAD FOR:  
PINZA PARA MARCADOR CON GOMA PARA:

**HEIDELBERG GTO / MO / KORD**

ORDINE MINIMO 5 PEZZI  
MINIMUM ORDER 5 PCS  
PEDIDO MÍNIMO 5 PIEZAS

COMPATIBLE WITH OEM PART

CODICE - CODE - CÓDIGO

**43.020.035F**

**4791**

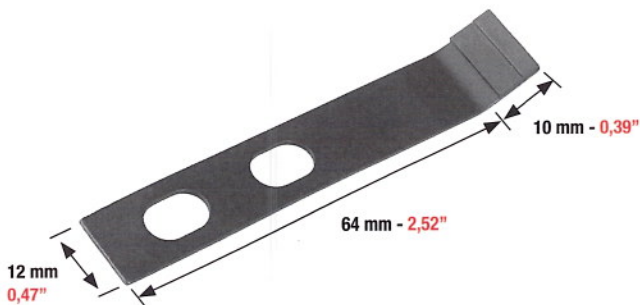

PINZA USCITA CON PUNTALE IN GOMMA PER  
EXIT GRIPPER WITH RUBBER PAD FOR  
PINZA DE SALIDA CON GOMA PARA

**HEIDELBERG S / SB / SBB / SBD**

ORDINE MINIMO 5 PEZZI  
MINIMUM ORDER 5 PCS  
PEDIDO MÍNIMO 5 PIEZAS

COMPATIBLE WITH OEM PART

CODICE - CODE - CÓDIGO

**03.014.051F**

**4822**

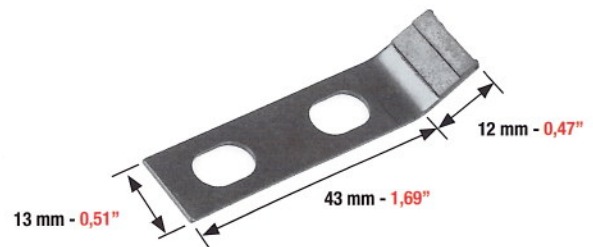

PINZA USCITA CON PUNTALE IN GOMMA PER  
EXIT GRIPPER WITH RUBBER PAD FOR  
PINZA DE SALIDA CON GOMA PARA

**HEIDELBERG S/SBB/SBB/SBD**

ORDINE MINIMO 5 PEZZI  
MINIMUM ORDER 5 PCS  
PEDIDO MÍNIMO 5 PIEZAS

COMPATIBLE WITH OEM PART

CODICE - CODE - CÓDIGO

**03.014.004F**

**48227**

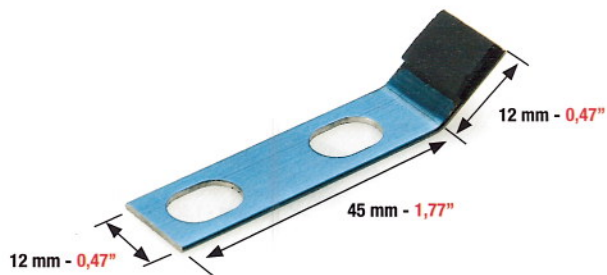

**PINZA USCITA MACCHINA TIPOGRAFICA PER:  
EXIT GRIPPER FOR LETTERPRESS MACHINE FOR:  
PINZA DE SALIDA PARA MAQUINA TIPOGRÁFICA PARA:**

**HEIDELBERG CYLINDER**

ORDINE MINIMO 5 PEZZI MINIMUM ORDER 5 PCS PEDIDO MÍNIMO 5 PIEZAS	COMPATIBLE WITH OEM PART .....	CODICE - CODE - CÓDIGO <b>4823</b>
--	-----------------------------------	---------------------------------------



**PINZA DI USCITA CON PUNTALE IN GOMMA PER:  
EXIT GRIPPER WITH RUBBER PAD FOR:  
PINZA DE SALIDA CON GOMA PARA:**

**HEIDELBERG SM52/GT0/KORD**

ORDINE MINIMO 5 PEZZI MINIMUM ORDER 5 PCS PEDIDO MÍNIMO 5 PIEZAS	COMPATIBLE WITH OEM PART .....	CODICE - CODE - CÓDIGO <b>14.875.001F</b>	<b>4800</b>
--	-----------------------------------	--	-------------

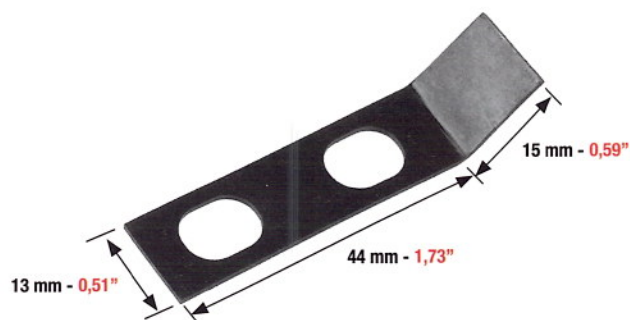

**PINZA DI USCITA PER  
EXIT GRIPPER FOR  
PINZA DE SALIDA PARA**

**HEIDELBERG SM52/GT0/KORD**

ORDINE MINIMO 5 PEZZI MINIMUM ORDER 5 PCS PEDIDO MÍNIMO 5 PIEZAS	COMPATIBLE WITH OEM PART .....	CODICE - CODE - CÓDIGO <b>48224</b>
--	-----------------------------------	--

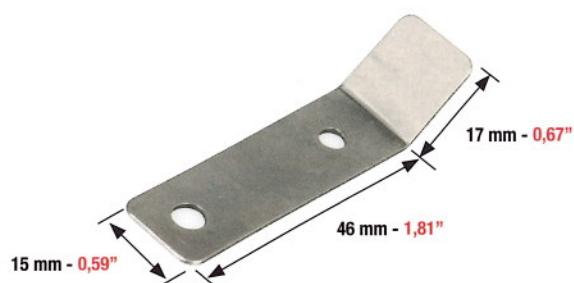

**PINZA DI USCITA PER  
EXIT GRIPPER FOR  
PINZA DE SALIDA PARA**

**HEIDELBERG SM74/CD74/XL75/XL105**

ORDINE MINIMO 5 PEZZI MINIMUM ORDER 5 PCS PEDIDO MÍNIMO 5 PIEZAS	COMPATIBLE WITH OEM PART .....	CODICE - CODE - CÓDIGO <b>L4.014.003/05</b>	<b>48221</b>
--	-----------------------------------	--	--------------

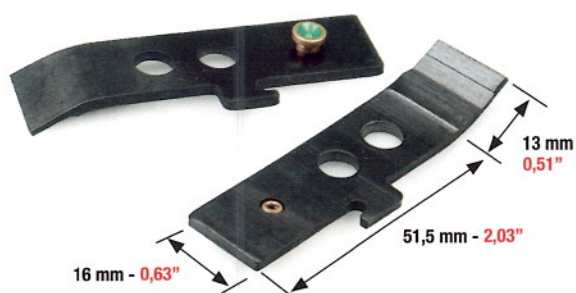

**PINZA DI USCITA CON GANCIO (DX) PER:  
HOOKED EXIT GRIPPER (RIGHT) FOR:  
PINZA DE SALIDA CON GANCHO (DERECHA) PARA:**

**HEIDELBERG SM74**

ORDINE MINIMO 5 PEZZI MINIMUM ORDER 5 PCS PEDIDO MÍNIMO 5 PIEZAS	COMPATIBLE WITH OEM PART <b>M2.014.011</b>	CODICE - CODE - CÓDIGO <b>48222</b>
--	---	--

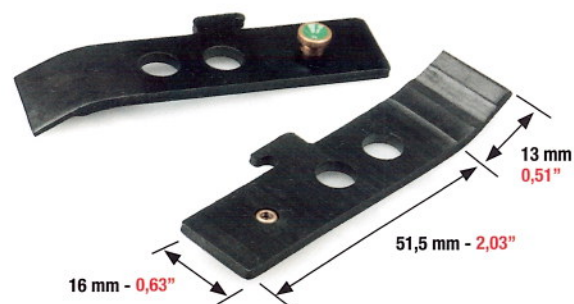

**PINZA DI USCITA CON GANCIO (SX) PER:  
HOOKED EXIT GRIPPER (LEFT) FOR:  
PINZA DE SALIDA CON GANCHO (IZQUIERDA) PARA :**

**HEIDELBERG SM74**

ORDINE MINIMO 5 PEZZI MINIMUM ORDER 5 PCS PEDIDO MÍNIMO 5 PIEZAS	COMPATIBLE WITH OEM PART <b>M2.015.004</b>	CODICE - CODE - CÓDIGO <b>48223</b>
--	---	--

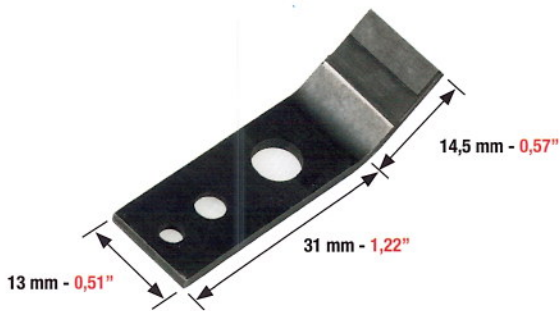

**PINZA DI USCITA PER:  
EXIT GRIPPER FOR:  
PINZA DE SALIDA PARA:**

**HEIDELBERG MO**

ORDINE MINIMO 5 PEZZI MINIMUM ORDER 5 PCS PEDIDO MÍNIMO 5 PIEZAS	COMPATIBLE WITH OEM PART	CODICE - CODE - CÓDIGO
	<b>43.014.004</b>	<b>48225</b>

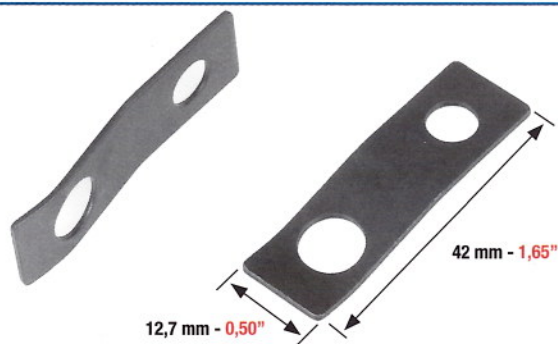

**PIASTRA DI SUPPORTO DI USCITA PER:  
EXIT BACKING PLATE FOR:  
PLACA DE APOYO DE SALIDA PARA:**

**HEIDELBERG GTO/KORD**

ORDINE MINIMO 5 PEZZI MINIMUM ORDER 5 PCS PEDIDO MÍNIMO 5 PIEZAS	COMPATIBLE WITH OEM PART	CODICE - CODE - CÓDIGO
	<b>14.014.041</b>	<b>48226</b>

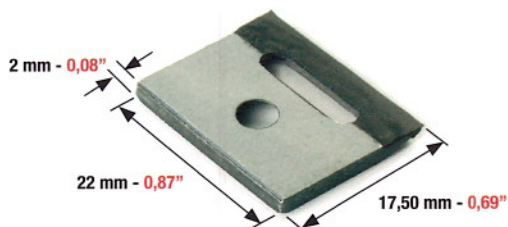

**PINZA DEL CILINDRO DI TRASFERIMENTO PER:  
TRANSFER CYLINDER GRIPPER FOR:  
PINZA PARA CILINDRO DE TRANSFERENCIA PARA:**

**HEIDELBERG QUICKMASTER/TOK  
TUTTI I MODELLI - ALL MODELS - TODOS LOS MODELOS**

ORDINE MINIMO 2 PEZZI MINIMUM ORDER 2 PCS PEDIDO MÍNIMO 2 PIEZAS	COMPATIBLE WITH OEM PART	CODICE - CODE - CÓDIGO
	....	<b>4804</b>

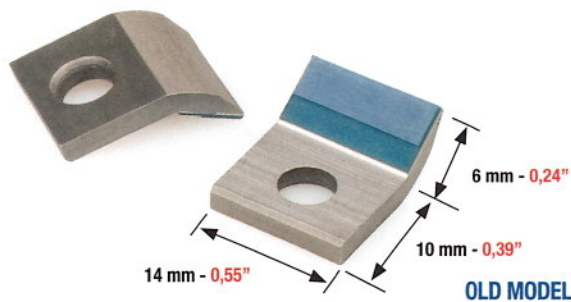

**PINZA DEL CILINDRO DI TRASFERIMENTO CON PUNTALE IN GOMMA PER:  
TRANSFER CYLINDER GRIPPER WITH RUBBER PAD FOR:  
PINZA DEL CILINDRO DE TRANSFERENCIA CON GOMA PARA:**

**HEIDELBERG MO**

ORDINE MINIMO 5 PEZZI MINIMUM ORDER 5 PCS PEDIDO MÍNIMO 5 PIEZAS	COMPATIBLE WITH OEM PART	CODICE - CODE - CÓDIGO
	<b>69.011.727</b>	<b>4803</b>

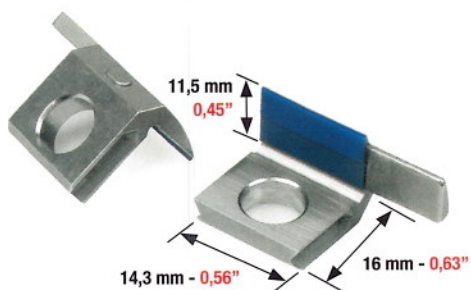

**PINZA ALATA DEL CILINDRO DI TRASFERIMENTO PER:  
WINGED GRIPPER FOR TRANSFER CYLINDER FOR:  
PINZA ALA DEL CILINDRO DE TRANSFERENCIA PARA:**

**HEIDELBERG XL105**

ORDINE MINIMO 5 PEZZI MINIMUM ORDER 5 PCS PEDIDO MÍNIMO 5 PIEZAS	COMPATIBLE WITH OEM PART	CODICE - CODE - CÓDIGO
	<b>F4.005.126</b>	<b>48202</b>

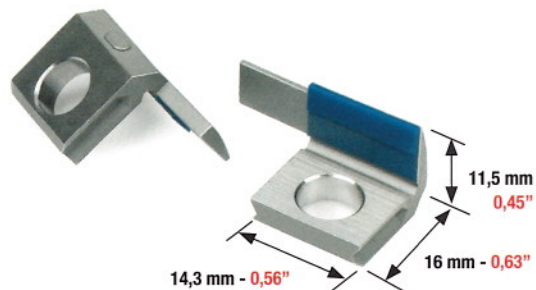

**PINZA ALATA DEL CILINDRO DI TRASFERIMENTO PER:  
WINGED GRIPPER FOR TRANSFER CYLINDER FOR:  
PINZA ALA DEL CILINDRO DE TRANSFERENCIA PARA:**

**HEIDELBERG XL105**

ORDINE MINIMO 5 PEZZI MINIMUM ORDER 5 PCS PEDIDO MÍNIMO 5 PIEZAS	COMPATIBLE WITH OEM PART	CODICE - CODE - CÓDIGO
	<b>F4.005.125</b>	<b>48203</b>



PINZA CON GANCIO DEL CILINDRO DI PRESSIONE PER:  
HOOKED GRIPPER FOR IMPRESSION CYLINDER FOR:  
PINZA CON GANCHO DEL CILINDRO DE IMPRESION PARA:

**HEIDELBERG XL105**

ORDINE MINIMO 5 PEZZI MINIMUM ORDER 5 PCS PEDIDO MÍNIMO 5 PIEZAS	COMPATIBLE WITH OEM PART	CODICE - CODE - CÓDIGO
	<b>F2.581.727</b>	<b>48201</b>

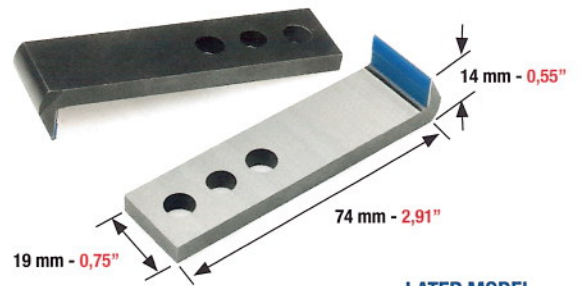

LATER MODEL

PINZA CON GANCIO DEL CILINDRO DI PRESSIONE PER:  
HOOKED GRIPPER FOR IMPRESSION CYLINDER FOR:  
PINZA CON GANCHO DEL CILINDRO DE IMPRESION PARA:

**HEIDELBERG SM102**

ORDINE MINIMO 5 PEZZI MINIMUM ORDER 5 PCS PEDIDO MÍNIMO 5 PIEZAS	COMPATIBLE WITH OEM PART	CODICE - CODE - CÓDIGO
	<b>C3.581.727N</b>	<b>48206</b>

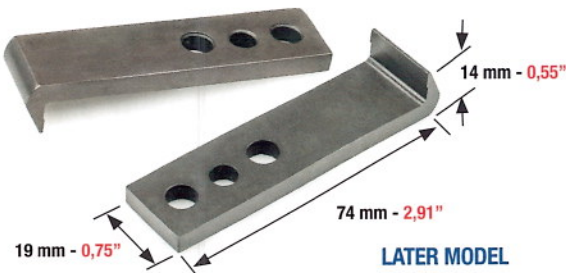

LATER MODEL

PINZA CON GANCIO DEL CILINDRO DI PRESSIONE PER:  
HOOKED GRIPPER FOR IMPRESSION CYLINDER FOR:  
PINZA CON GANCHO DEL CILINDRO DE IMPRESION PARA:

**HEIDELBERG SM102**

ORDINE MINIMO 5 PEZZI MINIMUM ORDER 5 PCS PEDIDO MÍNIMO 5 PIEZAS	COMPATIBLE WITH OEM PART	CODICE - CODE - CÓDIGO
	<b>C3.581.627N</b>	<b>48207</b>

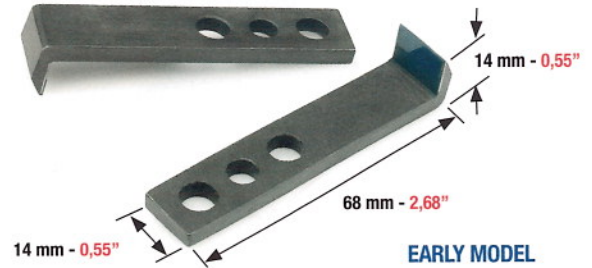

EARLY MODEL

PINZA CON GANCIO DEL CILINDRO DI PRESSIONE PER:  
HOOKED GRIPPER FOR IMPRESSION CYLINDER FOR:  
PINZA CON GANCHO DEL CILINDRO DE IMPRESION PARA:

**HEIDELBERG SM102/SM72**

ORDINE MINIMO 5 PEZZI MINIMUM ORDER 5 PCS PEDIDO MÍNIMO 5 PIEZAS	COMPATIBLE WITH OEM PART	CODICE - CODE - CÓDIGO
	<b>91.581.827N</b>	<b>48208</b>

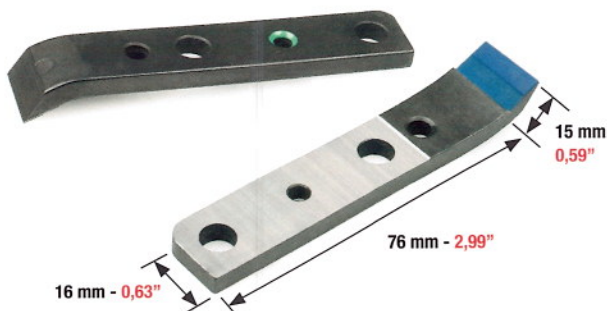

PINZA PER CILINDRI DI TRASFERIMENTO E DI PRESSIONE PER:  
GRIPPER FOR TRANSFER AND IMPRESSION CYLINDERS FOR:  
PINZA PARA CILINDROS DE TRANSFERENCIA Y DE IMPRESION PARA:

**HEIDELBERG SM102/CD102**

ORDINE MINIMO 5 PEZZI MINIMUM ORDER 5 PCS PEDIDO MÍNIMO 5 PIEZAS	COMPATIBLE WITH OEM PART	CODICE - CODE - CÓDIGO
	<b>C3.011.727</b>	<b>48204</b>

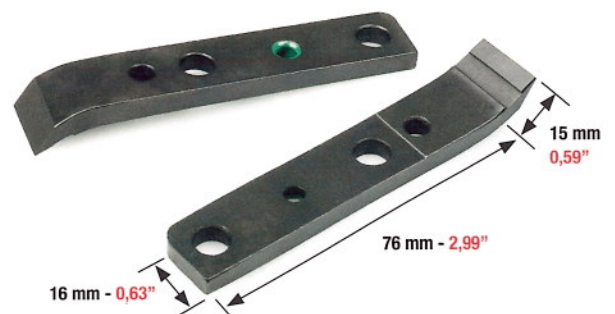

PINZA PER CILINDRI DI TRASFERIMENTO E DI PRESSIONE PER:  
GRIPPER FOR TRANSFER AND IMPRESSION CYLINDERS FOR:  
PINZA PARA CILINDROS DE TRANSFERENCIA Y DE IMPRESION PARA:

**HEIDELBERG SM102/CD102**

ORDINE MINIMO 5 PEZZI MINIMUM ORDER 5 PCS PEDIDO MÍNIMO 5 PIEZAS	COMPATIBLE WITH OEM PART	CODICE - CODE - CÓDIGO
	<b>C3.011.627</b>	<b>48205</b>

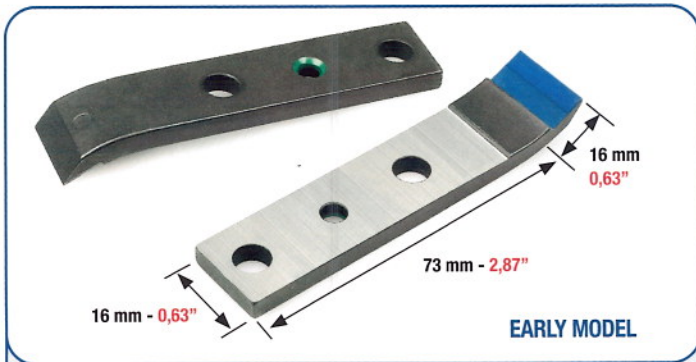

EARLY MODEL

PINZA PER CILINDRI DI TRASFERIMENTO E DI PRESSIONE PER:  
GRIPPER FOR TRANSFER AND IMPRESSION CYLINDERS FOR:  
PINZA PARA CILINDROS DE TRANSFERENCIA Y DE IMPRESION PARA:

**HEIDELBERG SM102/SM72**

ORDINE MINIMO 5 PEZZI MINIMUM ORDER 5 PCS PEDIDO MÍNIMO 5 PIEZAS	COMPATIBLE WITH OEM PART	CODICE - CODE - CÓDIGO
	49.011.827F	48209

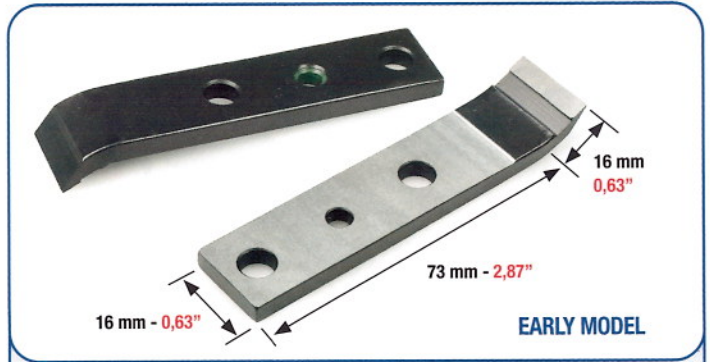

EARLY MODEL

PINZA CON GANCIO PER CILINDRI DI TRASFERIMENTO E DI PRESSIONE PER:  
HOOKED GRIPPER FOR TRANSFER AND IMPRESSION CYLINDERS FOR:  
PINZA CON GANCHO PARA CILINDROS DE TRANSFERENCIA Y DE IMPRESION PARA:

**HEIDELBERG SM102**

ORDINE MINIMO 5 PEZZI MINIMUM ORDER 5 PCS PEDIDO MÍNIMO 5 PIEZAS	COMPATIBLE WITH OEM PART	CODICE - CODE - CÓDIGO
	49.011.027	48210

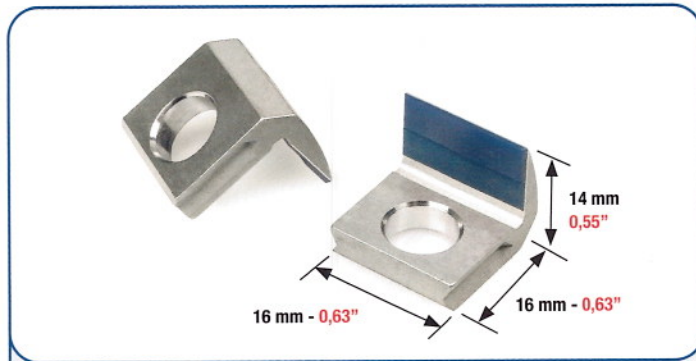

PINZA PER CILINDRI DI TRASFERIMENTO E DI PRESSIONE PER:  
GRIPPER FOR TRANSFER AND IMPRESSION CYLINDERS FOR:  
PINZA PARA CILINDROS DE TRANSFERENCIA Y DE IMPRESION PARA:

**HEIDELBERG SM74/SM52**

ORDINE MINIMO 5 PEZZI MINIMUM ORDER 5 PCS PEDIDO MÍNIMO 5 PIEZAS	COMPATIBLE WITH OEM PART	CODICE - CODE - CÓDIGO
	M4.011.727	4806

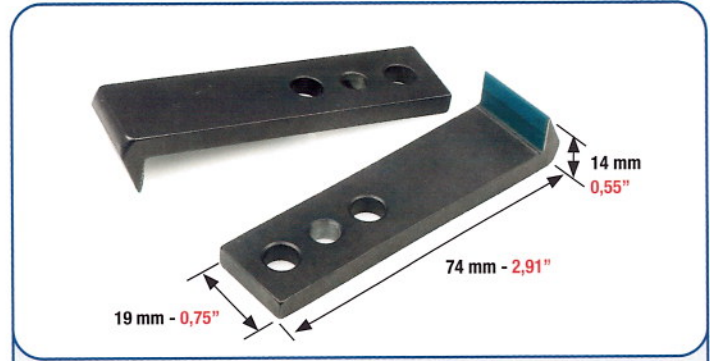

PINZA CON GANCIO PER CILINDRI DI TRASFERIMENTO E DI PRESSIONE PER:  
HOOKED GRIPPER FOR TRANSFER AND IMPRESSION CYLINDERS FOR:  
PINZA CON GANCHO PARA CILINDROS DE TRANSFERENCIA Y DE IMPRESION PARA:

**HEIDELBERG GTO/MO**

ORDINE MINIMO 5 PEZZI MINIMUM ORDER 5 PCS PEDIDO MÍNIMO 5 PIEZAS	COMPATIBLE WITH OEM PART	CODICE - CODE - CÓDIGO
	52.581.027	4808

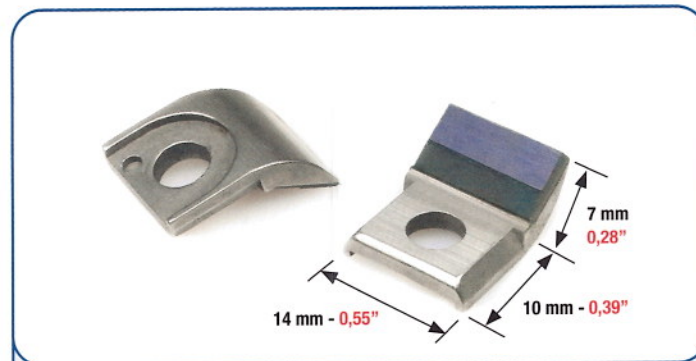

PINZA PER CILINDRI DI TRASFERIMENTO E DI PRESSIONE PER:  
GRIPPER FOR TRANSFER AND IMPRESSION CYLINDERS FOR:  
PINZA PARA CILINDROS DE TRANSFERENCIA Y DE IMPRESION PARA:

**HEIDELBERG GTO**

ORDINE MINIMO 5 PEZZI MINIMUM ORDER 5 PCS PEDIDO MÍNIMO 5 PIEZAS	COMPATIBLE WITH OEM PART	CODICE - CODE - CÓDIGO
	69.011.827	4802-A

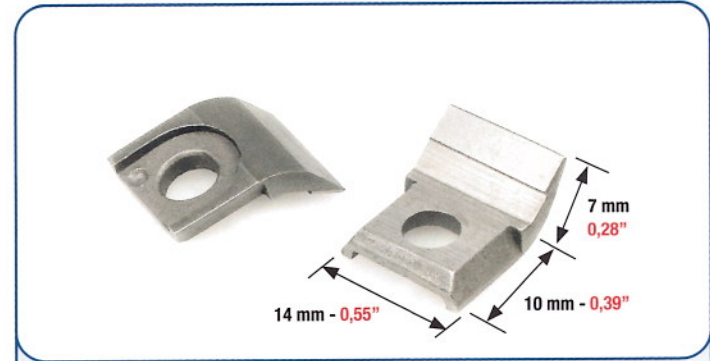

PINZA PER CILINDRI DI TRASFERIMENTO E DI PRESSIONE PER:  
GRIPPER FOR TRANSFER AND IMPRESSION CYLINDERS FOR:  
PINZA PARA CILINDROS DE TRANSFERENCIA Y DE IMPRESION PARA:

**HEIDELBERG GTO**

ORDINE MINIMO 5 PEZZI MINIMUM ORDER 5 PCS PEDIDO MÍNIMO 5 PIEZAS	COMPATIBLE WITH OEM PART	CODICE - CODE - CÓDIGO
	69.011.727	4802

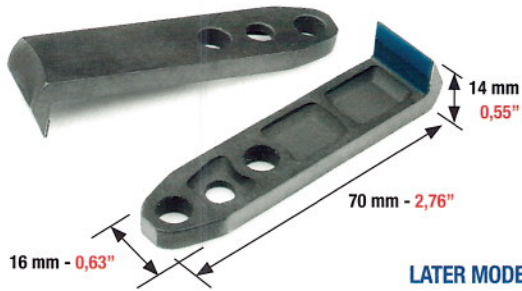

PINZA CON GANCIO DOUBLE DRUM PER:  
HOOKED GRIPPER DOUBLE DRUM FOR:  
PINZA CON GANCHO DOUBLE DRUM PARA:

**HEIDELBERG SM102**

ORDINE MINIMO 5 PEZZI MINIMUM ORDER 5 PCS PEDIDO MÍNIMO 5 PIEZAS	COMPATIBLE WITH OEM PART	CODICE - CODE - CÓDIGO
	<b>82.582.727N</b>	<b>48211</b>

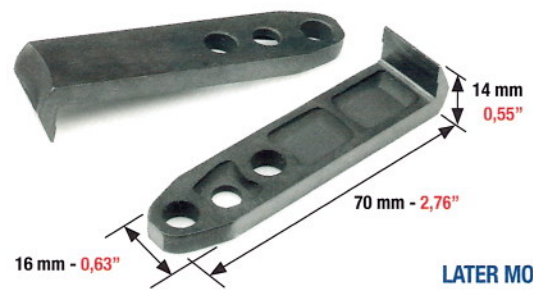

PINZA CON GANCIO DOUBLE DRUM PER:  
HOOKED GRIPPER DOUBLE DRUM FOR:  
PINZA CON GANCHO DOUBLE DRUM PARA:

**HEIDELBERG SM102**

ORDINE MINIMO 5 PEZZI MINIMUM ORDER 5 PCS PEDIDO MÍNIMO 5 PIEZAS	COMPATIBLE WITH OEM PART	CODICE - CODE - CÓDIGO
	<b>82.582.627N</b>	<b>48212</b>

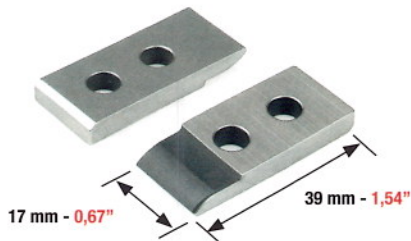

PINZA SUPERIORE PER:  
UPPER GRIPPER FOR:  
PINZA SUPERIOR PARA:

**HEIDELBERG SM102/SM72**

ORDINE MINIMO 5 PEZZI MINIMUM ORDER 5 PCS PEDIDO MÍNIMO 5 PIEZAS	COMPATIBLE WITH OEM PART	CODICE - CODE - CÓDIGO
	<b>91.580.337</b>	<b>48213</b>

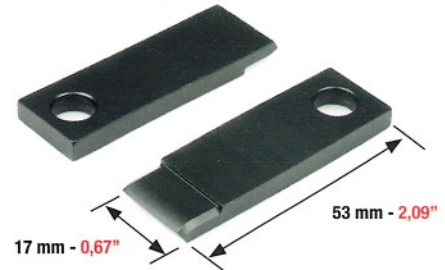

PINZA INFERIORE PER:  
LOWER GRIPPER FOR:  
PINZA INFERIOR PARA:

**HEIDELBERG SM102/SM72**

ORDINE MINIMO 5 PEZZI MINIMUM ORDER 5 PCS PEDIDO MÍNIMO 5 PIEZAS	COMPATIBLE WITH OEM PART	CODICE - CODE - CÓDIGO
	<b>91.580.338</b> <b>82.583.338</b>	<b>48214</b>

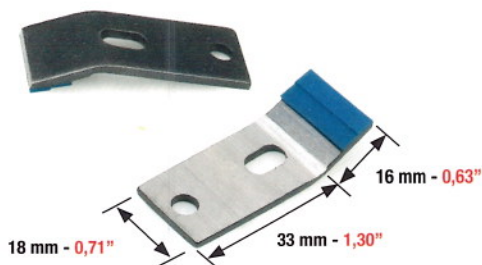

PINZA RANGER DRUM PER:  
GRIPPER RANGER DRUM FOR:  
PINZA RANGER DRUM PARA:

**HEIDELBERG SM102/SM72/SO/MO**

ORDINE MINIMO 5 PEZZI MINIMUM ORDER 5 PCS PEDIDO MÍNIMO 5 PIEZAS	COMPATIBLE WITH OEM PART	CODICE - CODE - CÓDIGO
	<b>27.013.049F</b>	<b>48215</b>



PINZA A DITO DI USCITA PER:  
GRIPPER FINGER FOR:  
DEDO PINZA DE SALIDA PARA:

**HEIDELBERG SM102/CD102**

	COMPATIBLE WITH OEM PART	CODICE - CODE - CÓDIGO
	<b>93.014.307</b>	<b>48216</b>

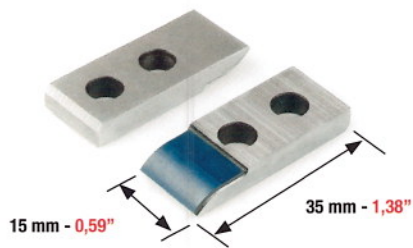

**PINZA SUPERIORE PER:  
UPPER GRIPPER FOR:  
PINZA SUPERIOR PARA:**

**HEIDELBERG SM74/PM74/SM52**

ORDINE MINIMO 5 PEZZI  
MINIMUM ORDER 5 PCS  
PEDIDO MÍNIMO 5 PIEZAS

COMPATIBLE WITH OEM PART

CODICE - CODE - CÓDIGO

**M2.583.637**

**4809**

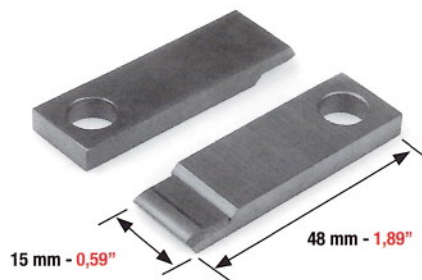

**PINZA INFERIORE PER:  
LOWER GRIPPER FOR:  
PINZA INFERIOR PARA:**

**HEIDELBERG SM74/PM74/SM52**

ORDINE MINIMO 5 PEZZI  
MINIMUM ORDER 5 PCS  
PEDIDO MÍNIMO 5 PIEZAS

COMPATIBLE WITH OEM PART

CODICE - CODE - CÓDIGO

**M2.583.398**

**4809-A**

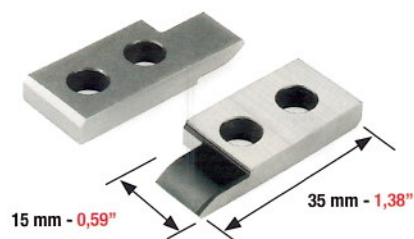

**PINZA SUPERIORE, META', PER:  
UPPER GRIPPER, HALF GRIP, FOR:  
PINZA SUPERIOR, MEDIA, PARA:**

**HEIDELBERG GTO/MO**

ORDINE MINIMO 5 PEZZI  
MINIMUM ORDER 5 PCS  
PEDIDO MÍNIMO 5 PIEZAS

COMPATIBLE WITH OEM PART

CODICE - CODE - CÓDIGO

**79.580.662**

**48217**

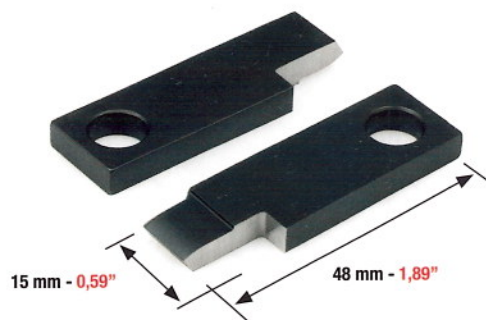

**PINZA INFERIORE, META', PER:  
LOWER GRIPPER, HALF GRIP, FOR:  
PINZA INFERIOR, MEDIA, PARA:**

**HEIDELBERG GTO/MO**

ORDINE MINIMO 5 PEZZI  
MINIMUM ORDER 5 PCS  
PEDIDO MÍNIMO 5 PIEZAS

COMPATIBLE WITH OEM PART

CODICE - CODE - CÓDIGO

**52.580.363**

**48218**

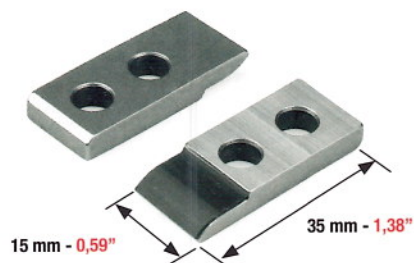

**PINZA SUPERIORE, PIENA, PER:  
UPPER GRIPPER, FULL GRIP, FOR:  
PINZA SUPERIOR, COMPLETA, PARA:**

**HEIDELBERG GTO/MO**

ORDINE MINIMO 5 PEZZI  
MINIMUM ORDER 5 PCS  
PEDIDO MÍNIMO 5 PIEZAS

COMPATIBLE WITH OEM PART

CODICE - CODE - CÓDIGO

**79.580.637**

**48219**

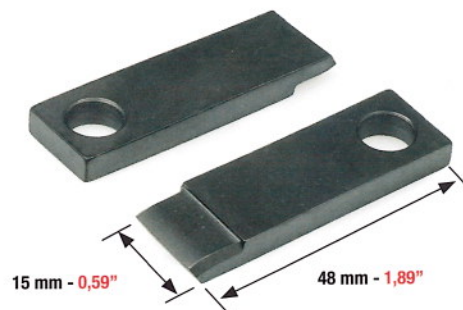

**PINZA INFERIORE, PIENA, PER:  
LOWER GRIPPER, FULL GRIP, FOR:  
PINZA INFERIOR, COMPLETA, PARA:**

**HEIDELBERG GTO/MO**

ORDINE MINIMO 5 PEZZI  
MINIMUM ORDER 5 PCS  
PEDIDO MÍNIMO 5 PIEZAS

COMPATIBLE WITH OEM PART

CODICE - CODE - CÓDIGO

**52.580.338**

**48220**



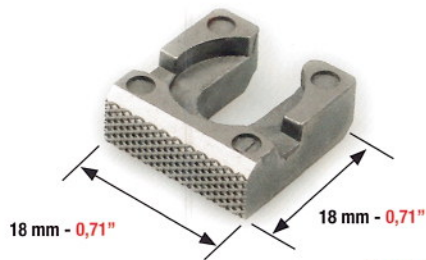

**DIAMOND GROOVE**

SUPPORTO PINZA PER:  
GRIPPER PAD FOR:  
SOPORTE DE PINZA PARA:

**HEIDELBERG SM102/CD102**

ORDINE MINIMO 5 PEZZI MINIMUM ORDER 5 PCS PEDIDO MÍNIMO 5 PIEZAS	COMPATIBLE WITH OEM PART	CODICE - CODE - CÓDIGO
	<b>C3.011.920</b>	<b>48231</b>

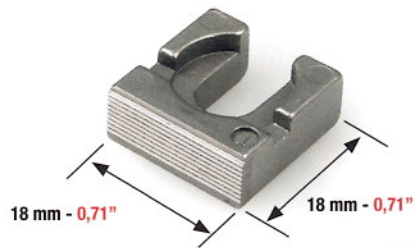

**PARALLEL GROOVE**

SUPPORTO PER PINZA PER:  
GRIPPER PAD FOR:  
SOPORTE DE PINZA PARA:

**HEIDELBERG SM102/CD102**

ORDINE MINIMO 5 PEZZI MINIMUM ORDER 5 PCS PEDIDO MÍNIMO 5 PIEZAS	COMPATIBLE WITH OEM PART	CODICE - CODE - CÓDIGO
	<b>C3.011.820</b>	<b>48232</b>

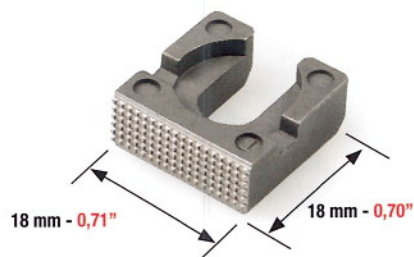

**CROSS GROOVE**

SUPPORTO PER PINZA PER:  
GRIPPER PAD FOR:  
SOPORTE DE PINZA PARA:

**HEIDELBERG SM102/CD102**

ORDINE MINIMO 5 PEZZI MINIMUM ORDER 5 PCS PEDIDO MÍNIMO 5 PIEZAS	COMPATIBLE WITH OEM PART	CODICE - CODE - CÓDIGO
	<b>C3.011.820</b>	<b>48233</b>

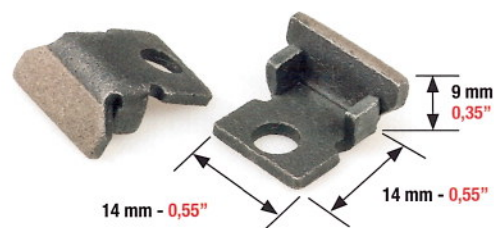

SUPPORTO PER PINZA PER:  
GRIPPER PAD FOR:  
SOPORTE DE PINZA PARA:

**HEIDELBERG SM102/CD102**

ORDINE MINIMO 5 PEZZI MINIMUM ORDER 5 PCS PEDIDO MÍNIMO 5 PIEZAS	COMPATIBLE WITH OEM PART	CODICE - CODE - CÓDIGO
	<b>93.525.310</b>	<b>48234</b>

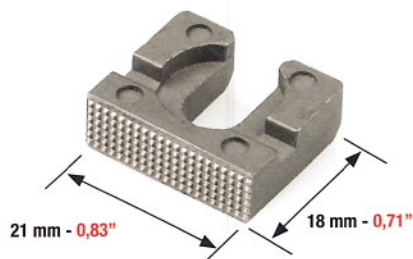

**CROSS GROOVE**

SUPPORTO PER PINZA PER:  
GRIPPER PAD FOR:  
SOPORTE DE PINZA PARA:

**HEIDELBERG SM102/CD102/SO**

ORDINE MINIMO 5 PEZZI MINIMUM ORDER 5 PCS PEDIDO MÍNIMO 5 PIEZAS	COMPATIBLE WITH OEM PART	CODICE - CODE - CÓDIGO
	<b>58.711.101</b>	<b>48235</b>

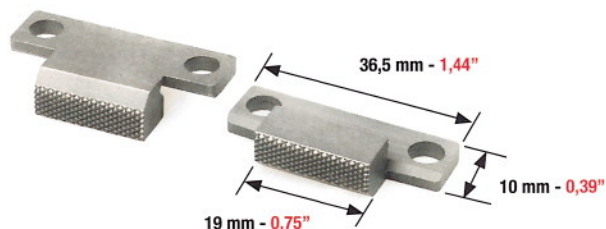

**DIAMOND GROOVE (T-SHAPED)**

SUPPORTO PER PINZA PER:  
GRIPPER PAD FOR:  
SOPORTE DE PINZA PARA:

**HEIDELBERG CD102**

ORDINE MINIMO 5 PEZZI MINIMUM ORDER 5 PCS PEDIDO MÍNIMO 5 PIEZAS	COMPATIBLE WITH OEM PART	CODICE - CODE - CÓDIGO
	<b>C3.581.920</b>	<b>48236</b>

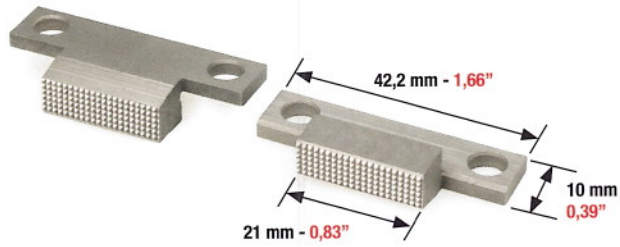

CROSS GROOVE (T-SHAPED)

SUPPORTO PER PINZA PER:  
GRIPPER PAD FOR:  
SOPORTE DE PINZA PARA:

**HEIDELBERG SM102/SM72**

ORDINE MINIMO 5 PEZZI  
MINIMUM ORDER 5 PCS  
PEDIDO MÍNIMO 5 PIEZAS

COMPATIBLE WITH OEM PART

CODICE - CODE - CÓDIGO

**91.581.620**

**48237**

**PARTI DI RICAMBIO  
REPLACEMENT SPARE PARTS  
PIEZAS DE RECAMBIO**

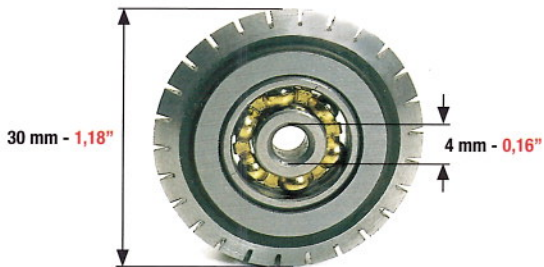

**PERFORAZIONE STANDARD 26 DENTI PER:  
STANDARD PERFORATING WHEEL 26 TEETH FOR:  
PERFORACIÓN ESTANDAR CON 26 DIENTES PARA:**

**HEIDELBERG GTO/PRINTMASTER/MO**

CODICE - CODE - CÓDIGO

**4690**

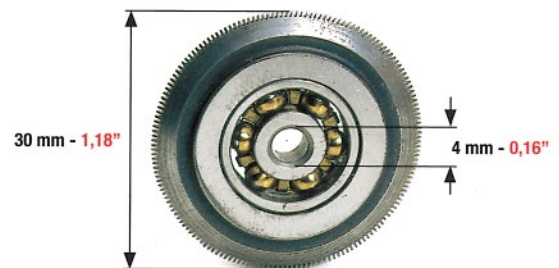

**MICROPERFORAZIONE 170 DENTI PER:  
MICROPERFORATING WHEEL 170 TEETH FOR:  
MICROPERFORACIÓN CON 170 DIENTES PARA:**

**HEIDELBERG GTO/PRINTMASTER/MO**

CODICE - CODE - CÓDIGO

**4695**

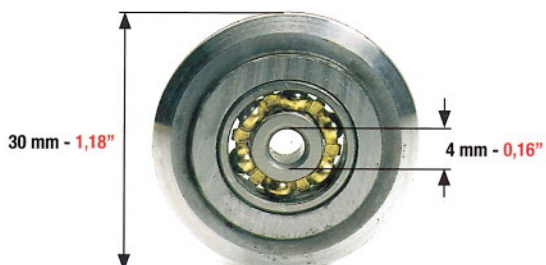

**CORDONATURA PER:  
CREASING WHEEL FOR:  
HENDIDO PARA:**

**HEIDELBERG GTO/PRINTMASTER/MO**

CODICE - CODE - CÓDIGO

**4700**

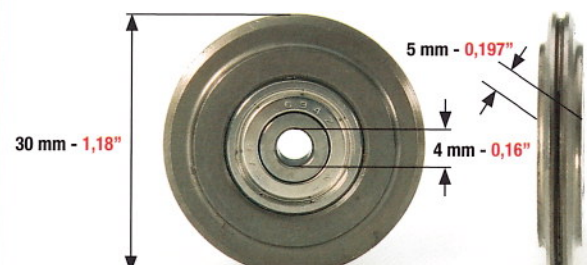

**DOPPIA CORDONATURA PER:  
DOUBLE CREASING WHEEL FOR:  
DOBLE HENDIDO PARA:**

**HEIDELBERG GTO/PRINTMASTER/MO**

CODICE - CODE - CÓDIGO

**4701**

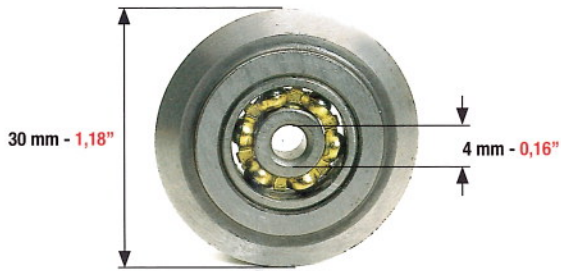

**TAGLIO PER:  
CUTTING WHEEL FOR:  
CORTE PARA:**

**HEIDELBERG GTO/PRINTMASTER/MO**

CODICE - CODE - CÓDIGO

**4710**

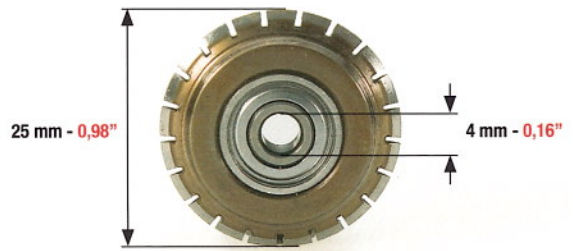

**PERFORAZIONE STANDARD 21 DENTI PER:  
STANDARD PERFORATING WHEEL 21 TEETH FOR:  
PERFORACIÓN ESTANDAR CON 21 DIENTES PARA:**

**HEIDELBERG SPEEDMASTER 52**

CODICE - CODE - CÓDIGO

**4682**

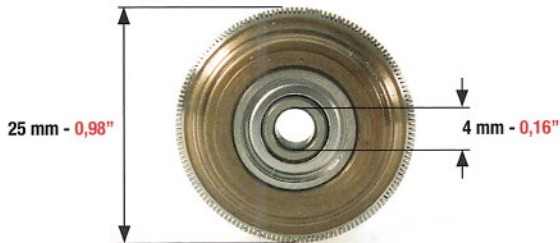

**MICROPERFORAZIONE 160 DENTI PER:  
MICROPERFORATING WHEEL 160 TEETH FOR:  
MICROPERFORACIÓN CON 160 DIENTES PARA:**

**HEIDELBERG SPEEDMASTER 52**

CODICE - CODE - CÓDIGO

**4683**

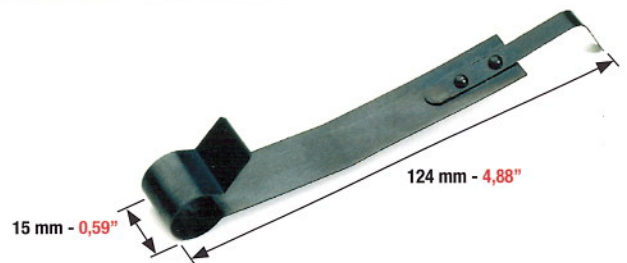

PLATINA PICCOLA 26x38 E PLATINA GRANDE 32x46  
FOR PLATEN "T" 26x38 AND "GT" 32x46  
PARA PLATINA MINERVA "T" 26x38 - PLATINA MINERVA "GT" 32x46

**MOLLA LATERALE PER:  
LATERAL SPRING FOR:  
MUELLE LATERAL PARA:**

**HEIDELBERG**

ORDINE MINIMO 5 PEZZI  
MINIMUM ORDER 5 PCS  
PEDIDO MÍNIMO 5 PIEZAS

CODICE - CODE - CÓDIGO

**4760**



PLATINA PICCOLA 26x38  
E PLATINA GRANDE 32x46  
FOR PLATEN "T" 26x38  
AND "GT" 32x46  
PARA PLATINA MINERVA "T" 26x38  
PLATINA MINERVA "GT" 32x46

**LINGUETTA CENTRALE PER:  
CENTRAL SHEET SEPARATOR FOR:  
LENGÜETA CENTRAL PARA:**

**HEIDELBERG**

ORDINE MINIMO 5 PEZZI  
MINIMUM ORDER 5 PCS  
PEDIDO MÍNIMO 5 PIEZAS

CODICE - CODE - CÓDIGO

**4750**

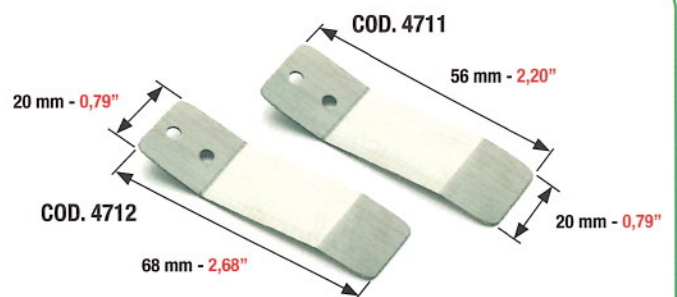

**SPATOLA PICCOLA PER ENTRATA METTIFOGLIO PER:  
SMALL SHEET SMOOTHER PLATE SPRING FOR:  
ESPÁTULA PEQUEÑA PARA LA ENTRADA DEL MARCADOR PARA:**

**HEIDELBERG  
SPEEDMASTER 102/72/74/SORM Z/SORK**

ORDINE MINIMO 2 PEZZI  
MINIMUM ORDER 2 PCS  
PEDIDO MÍNIMO 2 PIEZAS

CODICE - CODE - CÓDIGO

**4711**

**4712**

SPESSORE  
THICKNESS - GROSOR

0,60 mm - 0,024"

0,60 mm - 0,024"



LINGUETTA ADESIVA PER SPATOLA PICCOLA PER:  
ADHESIVE SEPARATOR FOR SMALL PLATE SPRING FOR:  
LENGÜETA ADHESIVA PARA ESPÁTULA PEQUEÑA PARA:

**HEIDELBERG  
SPEEDMASTER 102/72/74/SORM/SORS**

ORDINE MINIMO 2 PEZZI  
MINIMUM ORDER 2 PCS  
PEDIDO MÍNIMO 2 PIEZAS

CODICE - CODE - CÓDIGO

**4713**



LINGUETTA GRANDE PER SPATOLA METTIFOGLIO CENTRALE PER:  
LARGE CENTRAL PLATE SPRING FOR:  
LENGÜETA GRANDE PARA ESPÁTULA DEL MARCADOR CENTRAL PARA:

**HEIDELBERG  
SPEEDMASTER 102/72/74/SORM/SORS**

ORDINE MINIMO 2 PEZZI  
MINIMUM ORDER 2 PCS  
PEDIDO MÍNIMO 2 PIEZAS

CODICE - CODE - CÓDIGO

**4714**

SPESSORE  
THICKNESS - GROSOR

0,10 mm - 0,004"



LINGUETTA PER SPATOLA LATERALE PER:  
LATERAL PLATE SPRING FOR:  
LENGÜETA PARA ESPÁTULA DEL MARCADOR LATERAL PARA:

**HEIDELBERG  
SPEEDMASTER 102/72/SORM/SORS**

ORDINE MINIMO 2 PEZZI  
MINIMUM ORDER 2 PCS  
PEDIDO MÍNIMO 2 PIEZAS

CODICE - CODE - CÓDIGO

**4715**

SPESSORE  
THICKNESS - GROSOR

0,10 mm - 0,004"

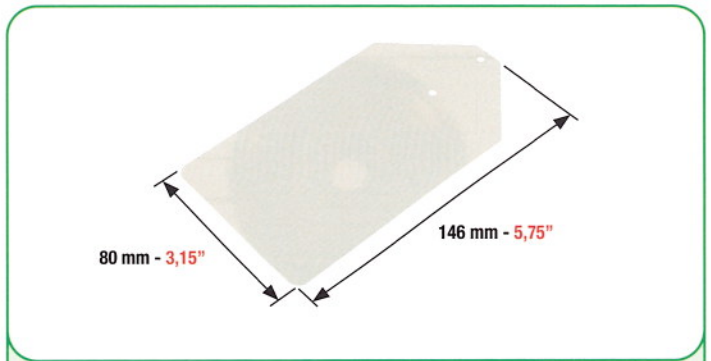

LINGUETTA PICCOLA PER SPATOLA METTIFOGLIO CENTRALE PER:  
SMALL CENTRAL PLATE SPRING FOR:  
LENGÜETA PEQUEÑA PARA ESPÁTULA DEL MARCADORE CENTRAL PARA:

**HEIDELBERG  
SPEEDMASTER 102/72/74/SORM/SORS**

ORDINE MINIMO 2 PEZZI  
MINIMUM ORDER 2 PCS  
PEDIDO MÍNIMO 2 PIEZAS

CODICE - CODE - CÓDIGO

**4716**

SPESSORE  
THICKNESS - GROSOR

0,10 mm - 0,004"

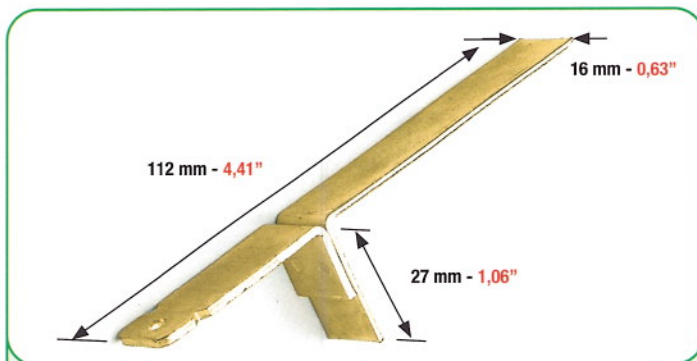

GUIDA FERMAFOGLIO USCITA PER:  
SHEET STOP GUIDE FOR:  
GUÍA DE PARADA DEL PAPEL PARA:

**HEIDELBERG GTO 46/52**

CODICE - CODE - CÓDIGO

**4880**

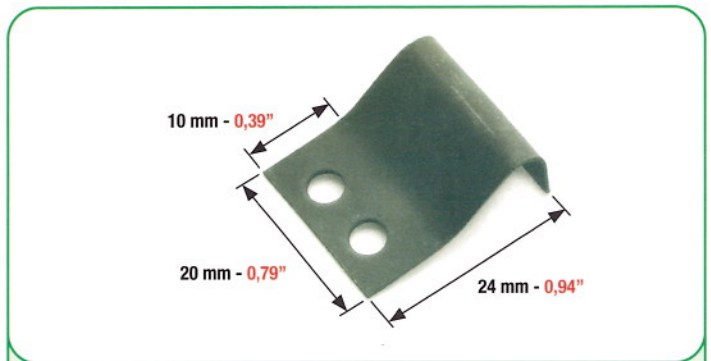

MOLLA PER GUIDAFOGLIO PER:  
SHEET GUIDE SPRING FOR:  
MUELLE PARA GUIA DEL PAPEL PARA:

**HEIDELBERG GTO**

CODICE - CODE - CÓDIGO

**4805**

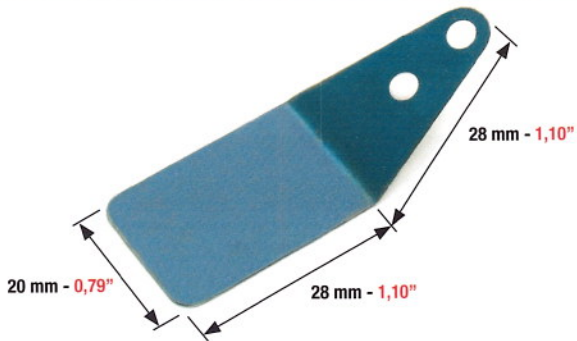

LINGUETTA GUIDAFOGLIO PER:  
SHEET GUIDE FOR:  
LENGÜETA GUIA DEL PAPEL PARA:

**HEIDELBERG GTO 46/GTO 52**

CODICE - CODE - CÓDIGO

**4807**

SPESSORE  
THICKNESS - GROSOR

0,25 mm - 0,010"

**Standard**

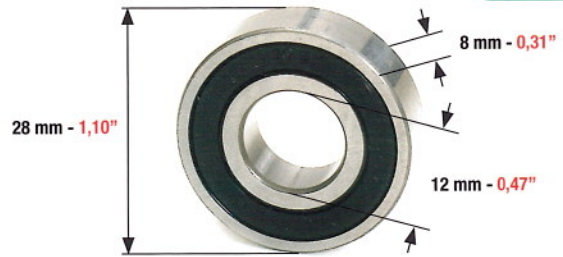

CUSCINETTO PER RULLI:  
BEARING FOR:  
RODAMIENTO DE LOS RODILLOS PARA:

**HEIDELBERG GTO 46/52/MO**

CODICE - CODE - CÓDIGO

**4745**

ORDINE MINIMO 5 PEZZI  
MINIMUM ORDER 5 PCS  
PEDIDO MÍNIMO 5 PIEZAS

**Special**

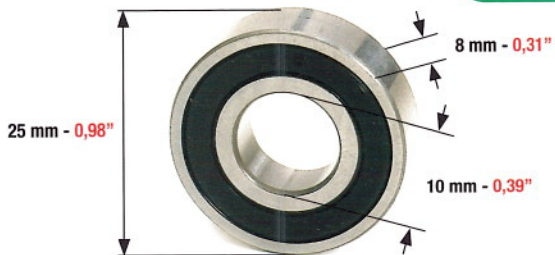

CUSCINETTO PER RULLI:  
BEARING FOR:  
RODAMIENTO DE LOS RODILLOS PARA:

**HEIDELBERG GTO 46/52/MO**

CODICE - CODE - CÓDIGO

**4746**

ORDINE MINIMO 5 PEZZI  
MINIMUM ORDER 5 PCS  
PEDIDO MÍNIMO 5 PIEZAS

**Original**

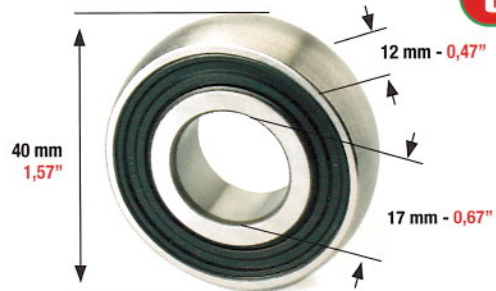

CUSCINETTO PER RULLI PER:  
BEARING FOR:  
RODAMIENTO DE LOS RODILLOS PARA:

**HEIDELBERG SORS/SPEEDMASTER**

CODICE - CODE - CÓDIGO

**4747**

ORDINE MINIMO 5 PEZZI  
MINIMUM ORDER 5 PCS  
PEDIDO MÍNIMO 5 PIEZAS

**Special**

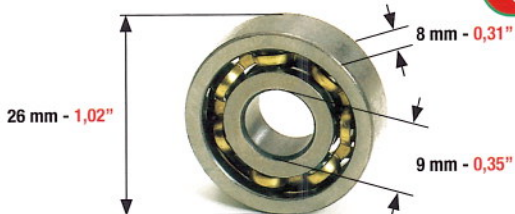

PLATINA PICCOLA 26x38 E PLATINA GRANDE 32x46  
FOR PLATEN "T" 26x38 AND "GT" 32x46  
PARA PLATINA MINERVA "T" 26x38 - PLATINA MINERVA "GT" 32x46

CUSCINETTO PER RULLI INCHIOSTRATORI PER:  
BEARING FOR INKING ROLLERS FOR:  
RODAMIENTO DE LOS RODILLOS ENTINTADORES PARA:

**HEIDELBERG**

CODICE - CODE - CÓDIGO

**4740**

ORDINE MINIMO 5 PEZZI  
MINIMUM ORDER 5 PCS  
PEDIDO MÍNIMO 5 PIEZAS

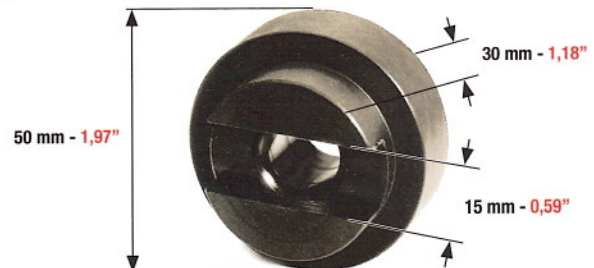

PLATINA PICCOLA 26x38 E PLATINA GRANDE 32x46  
FOR PLATEN "T" 26x38 AND "GT" 32x46  
PARA PLATINA MINERVA "T" 26x38 - PLATINA MINERVA "GT" 32x46

RUOTA IN PLASTICA PER RULLI INCHIOSTRATORI PER:  
PLASTIC WHEEL FOR INKING ROLLERS FOR:  
RUEDA DE PLASTICO PARA RODILLOS ENTINTADORES PARA:

**HEIDELBERG**

CODICE - CODE - CÓDIGO

**4755**

ORDINE MINIMO 5 PEZZI  
MINIMUM ORDER 5 PCS  
PEDIDO MÍNIMO 5 PIEZAS

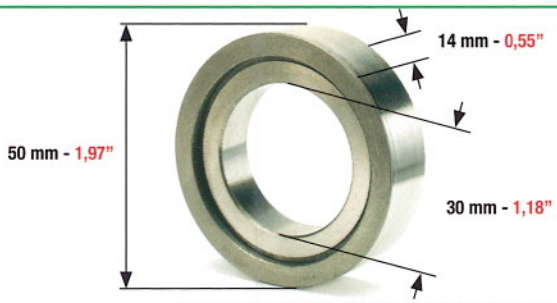

PLATINA PICCOLA 26x38 E PLATINA GRANDE 32x46  
FOR PLATEN "T" 26x38 AND "GT" 32x46  
PARA PLATINA MINERVA "T" 26x38 - PLATINA MINERVA "GT" 32x46

ANELLO DI PRESSIONE PER:  
PRESSURE RING FOR:  
ANILLO DE PRESIÓN PARA:

**HEIDELBERG**

CODICE - CODE - CÓDIGO

**4756**

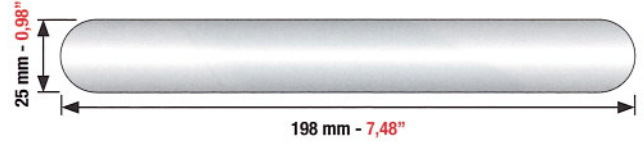

LAMETTA CALIBRATA PER LA REGOLAZIONE DELLA PRESSIONE DEI RULLI  
INCHIOSTRATORI

GAUGED STEEL BLADE FOR ADJUSTMENT OF INKING ROLLER PRESSURE  
CUCHILLA PEQUEÑA EN ACERO, CALIBRADA PARA LA REGULACIÓN DE LA  
PRESIÓN DE LOS RODILLOS ENTINTADORES

CONFEZIONE 4 PEZZI  
4 PCS PACKET  
CONFECCIONES DE 4 PIEZAS

CODICE - CODE - CÓDIGO

**4630**

SPESSORE  
THICKNESS - GROSOR

0,10 mm - 0,004"

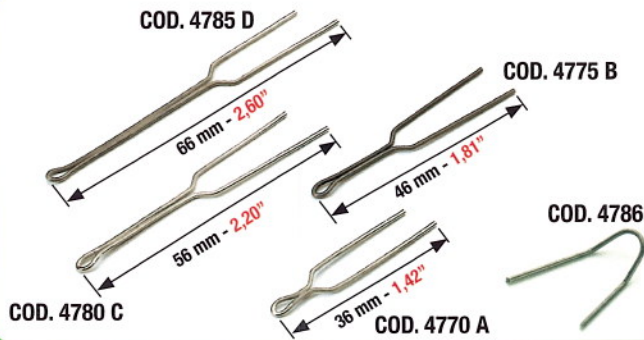

SPILLI PER PLATINA PER:  
PINS FOR PLATEN FOR:  
AGUJAS PARA "PLATINA" MINERVA PARA:

**HEIDELBERG**

CONFEZIONE DA 50 PEZZI  
PACKET OF 50 PCS  
CONFECCIONES DE 50 PIEZAS

CODICE - CODE - CÓDIGO

4770 A - 4775 B  
4780 C - 4785 D - 4786



**TOP QUALITY**



**PRODOTTO INTERAMENTE IN ITALIA  
PRODUCED ENTIRELY IN ITALY  
PRODUCIDO TOTALMENTE EN ITALIA**

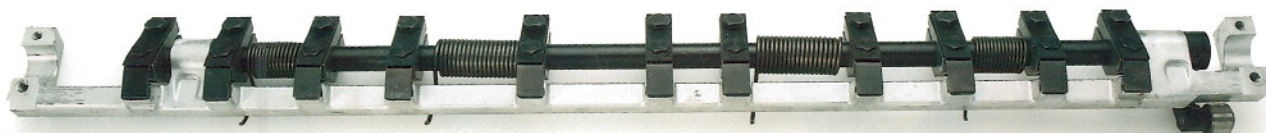

**BARRA PER PINZA USCITA PER:  
BAR FOR EXIT GRIPPER FOR:  
BARRA PARA PINZA DE SALIDA PARA:**

**HEIDELBERG GTO 46/52/KORD/KORS 72**

CODICE - CODE - CÓDIGO

4718 per/for/para GTO 46

4719 per/for/para GTO 52

CODICE - CODE - CÓDIGO

4721 per/for/para KORD

4722 per/for/para KORS 72



**TOP QUALITY**



**PRODOTTO INTERAMENTE IN ITALIA  
PRODUCED ENTIRELY IN ITALY  
PRODUCIDO TOTALMENTE EN ITALIA**



352 mm - 13,86"

**PINZA COMPLETA PER PLATINA PICCOLA 26x38 PER:  
COMPLETE GRIPPER BAR FOR PLATEN "T" 26x38 FOR:  
PINZA COMPLETA PARA PLATINA MINERVA PEQUEÑA 26x38 PARA:**

**HEIDELBERG**

CODICE - CODE - CÓDIGO

**4720**



**TOP QUALITY**



**PRODOTTO INTERAMENTE IN ITALIA  
PRODUCED ENTIRELY IN ITALY  
PRODUCIDO TOTALMENTE EN ITALIA**

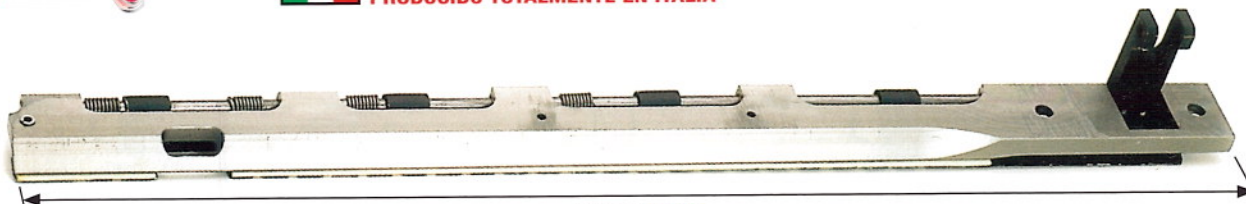

440 mm - 17,32"

**PINZA COMPLETA PER PLATINA GRANDE 32x46 PER:  
COMPLETE GRIPPER BAR FOR PLATEN "GT" 32x46 FOR:  
PINZA COMPLETA PARA "PLATINA" MINERVA GRANDE 32x46 PARA:**

**HEIDELBERG**

CODICE - CODE - CÓDIGO

**4730**



**ARTICOLI VARI  
SUNDRIES  
ARTICULOS VARIOS**

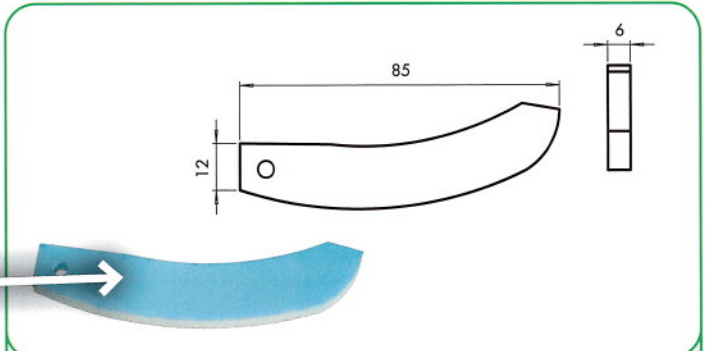
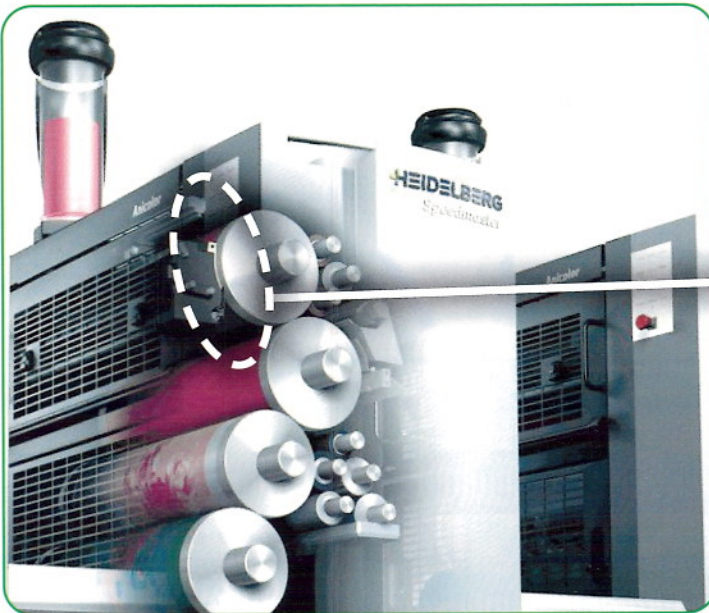

**GUARNIZIONE LATERALE IN ESPANSO PER LAVAGGIO SISTEMA PER:  
LATERAL SEAL IN FOAM FOR WASHING SYSTEMS FOR:  
GUARNICIONES LATERALES DE ESPUMA PARA SISTEMA DE LAVADO PARA:  
SPEEDMASTER 52 (ANICOLOR)**

CONFEZIONE DA 50 PEZZI PACKET OF 50 PCS CONFECCIÓN DE 50 PIEZAS	COMPATIBLE WITH OEM PART <b>G4.308.158F/01</b>	CODICE - CODE - CÓDIGO <b>18655</b>
---	---	--

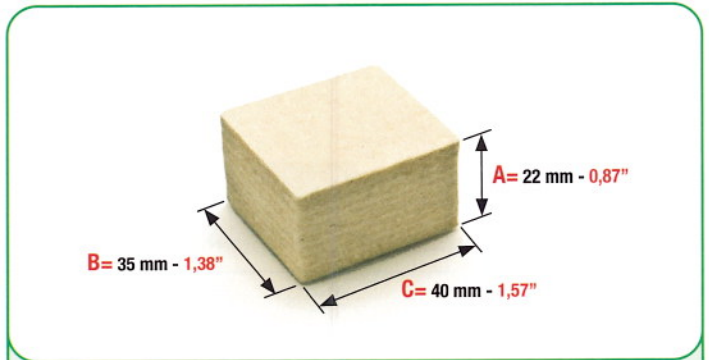

**FELTRINO PER PULIZIA ANELLI PER:  
FELT FOR CLEANING RINGS FOR:  
FIELTRO PEQUEÑO PARA LA LIMPIEZA DE ANILLOS PARA:  
HEIDELBERG HARRIS 845**

CONFEZIONE DA 20 PEZZI PACKET OF 20 PCS CONFECCIÓN DE 20 PIEZAS	CODICE - CODE - CÓDIGO <b>5153</b>
---	---------------------------------------

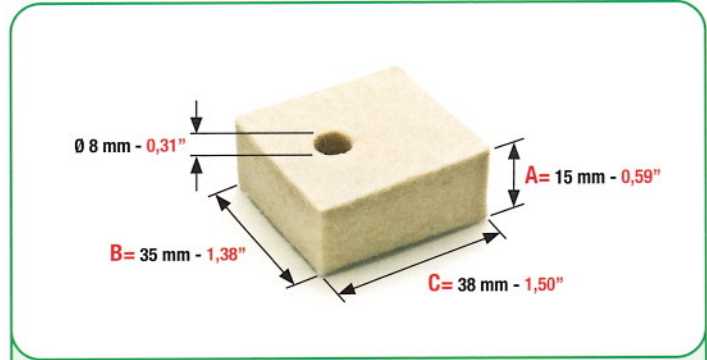

**FELTRINO PER PULIZIA ANELLI PER:  
FELT FOR CLEANING RINGS FOR:  
FIELTRO PEQUEÑO PARA LA LIMPIEZA DE ANILLOS PARA:  
HEIDELBERG HARRIS M 600/D**

CONFEZIONE DA 20 PEZZI PACKET OF 20 PCS CONFECCIÓN DE 20 PIEZAS	CODICE - CODE - CÓDIGO <b>5154</b>
---	---------------------------------------

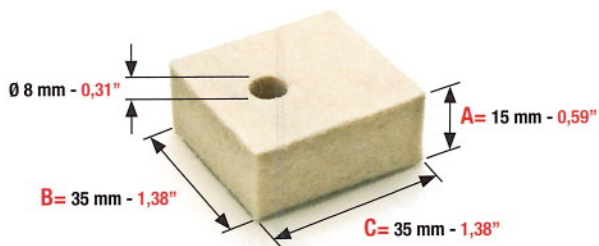

FELTRINO PER PULIZIA ANELLI PER:  
FELT FOR CLEANING RINGS FOR:  
FIELTRO PEQUEÑO PARA LA LIMPIEZA DE ANILLOS PARA:

**HEIDELBERG HARRIS M 600/D**

CONFEZIONE DA 20 PEZZI PACKET OF 20 PCS CONFECCIÓN DE 20 PIEZAS	CODICE - CODE - CÓDIGO
	<b>5154-BIS</b>

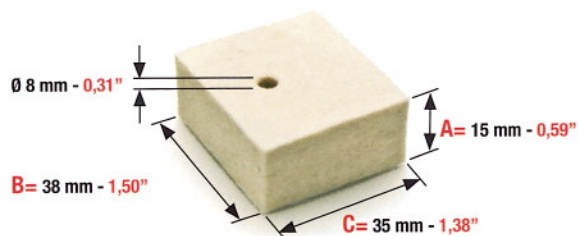

FELTRINO PER PULIZIA ANELLI PER:  
FELT FOR CLEANING RINGS FOR:  
FIELTRO PEQUEÑO PARA LA LIMPIEZA DE ANILLOS PARA:

**HEIDELBERG HARRIS M 600**

CONFEZIONE DA 20 PEZZI PACKET OF 20 PCS CONFECCIÓN DE 20 PIEZAS	CODICE - CODE - CÓDIGO
	<b>5154 A</b>

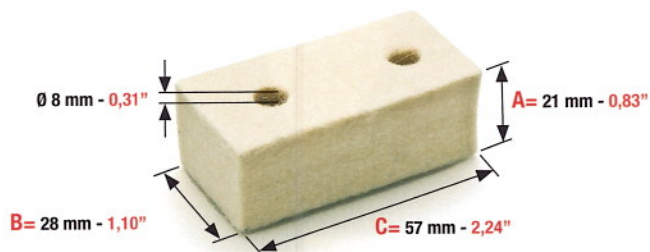

FELTRINO PER PULIZIA ANELLI PER:  
FELT FOR CLEANING RINGS FOR:  
FIELTRO PEQUEÑO PARA LA LIMPIEZA DE ANILLOS PARA:

**HEIDELBERG HARRIS M 1000**

CONFEZIONE DA 20 PEZZI PACKET OF 20 PCS CONFECCIÓN DE 20 PIEZAS	CODICE - CODE - CÓDIGO
	<b>5154 B</b>

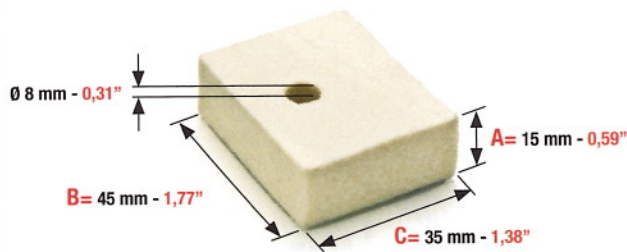

FELTRINO PER PULIZIA ANELLI PER:  
FELT FOR CLEANING RINGS FOR:  
FIELTRO PEQUEÑO PARA LA LIMPIEZA DE ANILLOS PARA:

**HEIDELBERG HARRIS M 600**

CONFEZIONE DA 20 PEZZI PACKET OF 20 PCS CONFECCIÓN DE 20 PIEZAS	CODICE - CODE - CÓDIGO
	<b>5156</b>

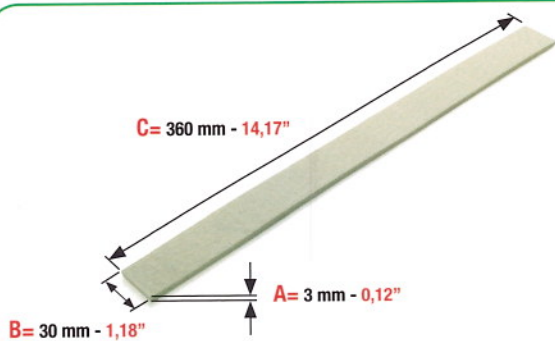

FELTRO DI BAGNATURA PER:  
DAMPENING FELT FOR:  
FIELTRO DE MOJADO PARA:

**QUICKMASTER 46**

SENZA FORI - WITHOUT HOLES - SIN AGUJEROS

ORDINE MINIMO 10 PEZZI MINIMUM ORDER 10 PCS PEDIDO MINIMO 10 PIEZAS	CODICE - CODE - CÓDIGO
	<b>5162</b>

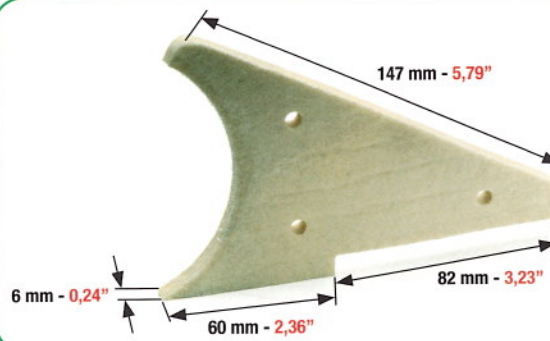

FELTRINO SAGOMATO PER CALAMAIO PER:  
SHAPED FELT FOR INK DUCT FOR:  
FIELTRO PEQUEÑO MOLDEADO PARA TINTERO PARA:

**WEB HARRIS M 200**

ORDINE MINIMO 5 COPPIE MINIMUM ORDER 5 PAIRS PEDIDO MINIMO 5 PARES	CODICE - CODE - CÓDIGO
	<b>5166</b>

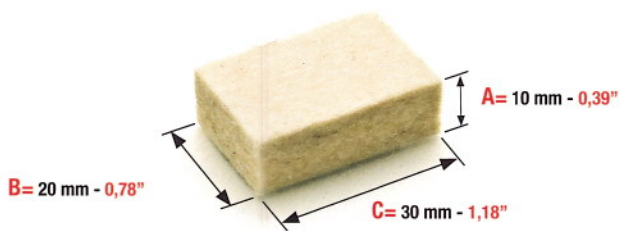

FELTRINO PER PULIZIA ANELLI PER:  
FELT FOR CLEANING RINGS FOR:  
FIELTRO PEQUEÑO PARA LA LIMPIEZA DE ANILLOS PARA:

**GOSS**

CONFEZIONE DA 20 PEZZI  
PACKET OF 20 PCS  
CONFECCIÓN DE 20 PIEZAS

CODICE - CODE - CÓDIGO

**5159 C**

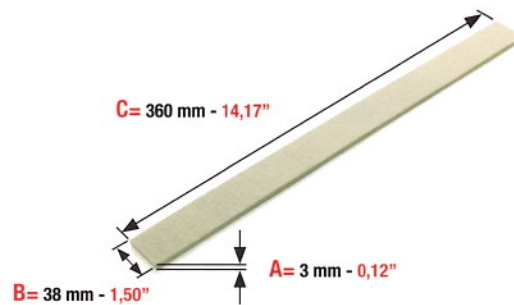

FELTRO DI BAGNATURA PER:  
DAMPENING FELT FOR:  
FIELTRO DE MOJADO PARA:

**PRINT MASTER 46**

SENZA FORI - WITHOUT HOLES - SIN AGUJEROS

ORDINE MINIMO 10 PEZZI  
MINIMUM ORDER 10 PCS  
PEDIDO MINIMO 10 PIEZAS

CODICE - CODE - CÓDIGO

**5167**

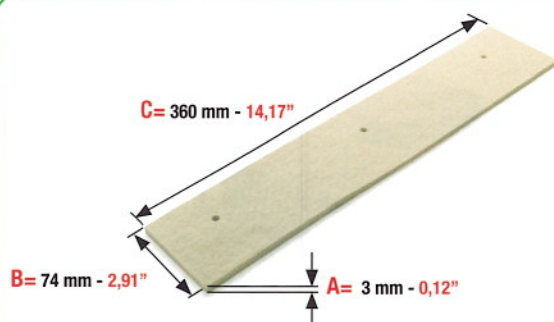

FELTRO DI BAGNATURA PER:  
DAMPENING FELT FOR:  
FIELTRO DE MOJADO PARA:

**QUICKMASTER 46 Di**  
3 FORI - 3 HOLES - 3 AGUJEROS

ORDINE MINIMO 5 PEZZI  
MINIMUM ORDER 5 PCS  
PEDIDO MINIMO 5 PIEZAS

CODICE - CODE - CÓDIGO

**5164**

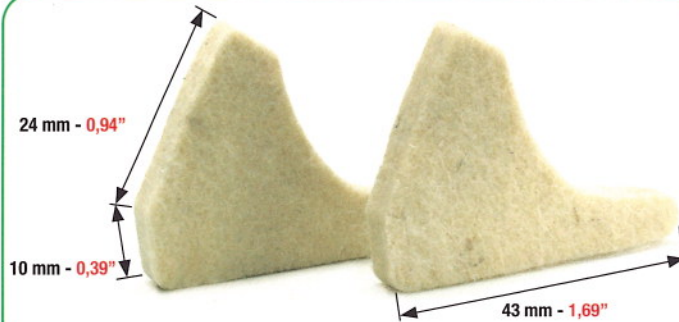

GUARNIZIONI LATERALI IN FELTRO PER SISTEMA DI LAVAGGIO KOMPAC PER:  
LATERAL SEALS IN FELT FOR KOMPAC WASHING SYSTEMS FOR:  
GUARNICIONES LATERALES DE FIELTRO PARA SISTEMA DE LAVADO KOMPAC PARA:

**HEIDELBERG GTO 46/GTO 52/MO65**

CONFEZIONE DA 20 PEZZI  
PACKET OF 20 PCS  
CONFECCIÓN DE 20 PIEZAS

CODICE - CODE - CÓDIGO

**5128**

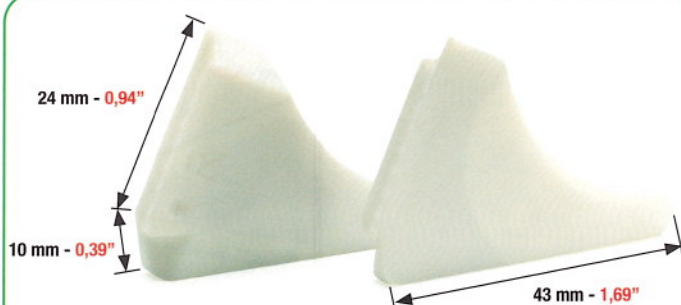

GUARNIZIONI LATERALI IN TEFLON PER IMPIANTI KOMPAC PER:  
LATERAL SEALS IN TEFLON FOR KOMPAC FOR:  
GUARNICIONES LATERALES DE TEFLÓN PARA INSTALACIONES KOMPAC PARA:

**HEIDELBERG GTO 46/GTO 52/MO 65**  
**ROLAND PRAKTIKA 00/01**

CONFEZIONE DA 2 PEZZI (DX E SX)  
PACKET OF 2 PCS (RIGHT AND LEFT)  
CONFECCIÓN DE 2 PIEZAS  
(DERECHA E IZQUIERDA)

CODICE - CODE - CÓDIGO

**5127**

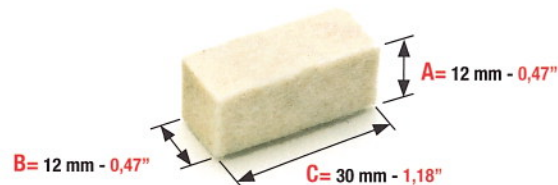

FELTRINO PER PULIZIA ANELLI PER:  
FELT FOR CLEANING RINGS FOR:  
FIELTRO PEQUEÑO PARA LA LIMPIEZA DE ANILLOS PARA:

**HEIDELBERG**

CONFEZIONE DA 20 PEZZI  
PACKET OF 20 PCS  
CONFECCIÓN DE 20 PIEZAS

CODICE - CODE - CÓDIGO

**5157**

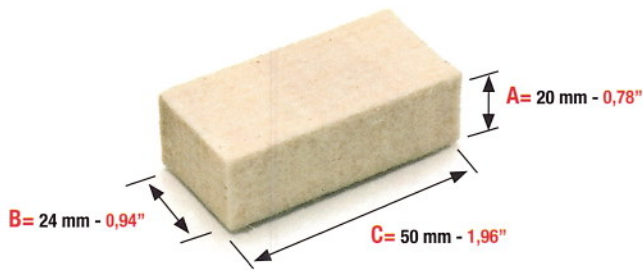

FELTRINO PER PULIZIA ANELLI PER:  
 FELT FOR CLEANING RINGS FOR:  
 FIELTRO PEQUEÑO PARA LA LIMPIEZA DE ANILLOS PARA:

**HEIDELBERG SPEEDMASTER 102**

CONFEZIONE DA 20 PEZZI  
 PACKET OF 20 PCS  
 CONFECCIÓN DE 20 PIEZAS

CODICE - CODE - CÓDIGO

**5157-A**

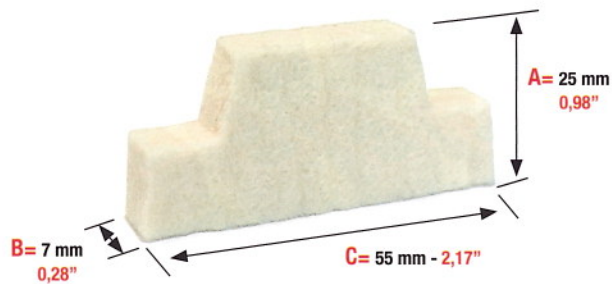

FELTRINO PER PULIZIA ANELLI PER:  
 FELT FOR CLEANING RINGS FOR:  
 FIELTRO PEQUEÑO PARA LA LIMPIEZA DE ANILLOS PARA:

**GOSS - G15 - 32 PAGES - GOSS UNIVERSAL 75**

CONFEZIONE DA 20 PEZZI  
 PACKET OF 20 PCS  
 CONFECCIÓN DE 20 PIEZAS

CODICE - CODE - CÓDIGO

**5191**

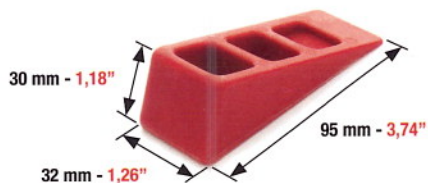

MISURA - SIZE - MEDIDA  
 mm 30 x 32 x 95

**CUNEO MINI  
 MINI PLASTIC WEDGE  
 CUÑA MINI**

**BABY**

CODICE - CODE - CÓDIGO

**5143**

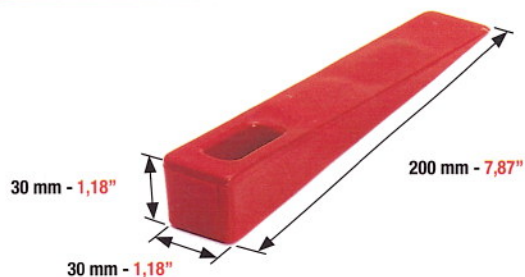

MISURA - SIZE - MEDIDA  
 mm 30 x 30 x 200

**CUNEO PICCOLO  
 SMALL PLASTIC WEDGE  
 CUÑA PEQUEÑA**

**SMALL**

CODICE - CODE - CÓDIGO

**5145**

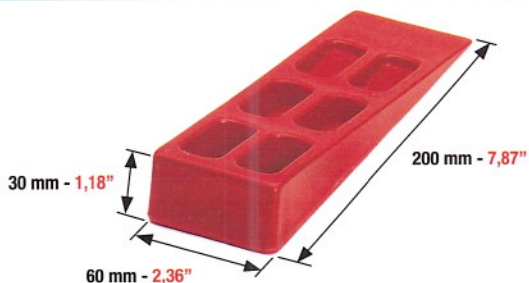

MISURA - SIZE - MEDIDA  
 mm 30 x 60 x 200

**CUNEO MEDIO  
 MEDIUM PLASTIC WEDGE  
 CUÑA MEDIANA**

**MEDIUM**

CODICE - CODE - CÓDIGO

**5150**



MISURA - SIZE - MEDIDA  
 mm 25 x 75 x 200

**CUNEO GRANDE  
 LARGE PLASTIC WEDGE  
 CUÑA GRANDE**

**LARGE**

CODICE - CODE - CÓDIGO

**5155**

**NEW**

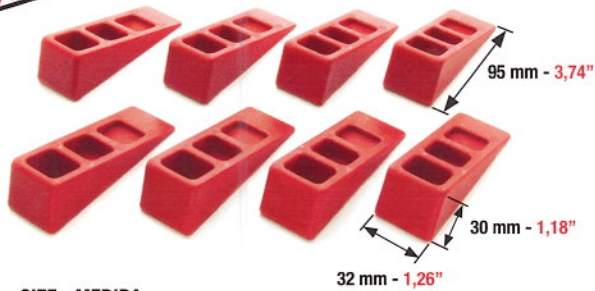

MISURA - SIZE - MEDIDA  
mm 30 x 32 x 95

SET COMPOSTO DA 8 CUNEI MINI DI UGUALE MISURA  
SET OF 8 MINI WEDGES OF THE SAME SIZE  
JUEGO COMPUESTO POR 8 CUÑAS MINI DE IGUAL TAMAÑO

**SET "0" (BABY)**

CODICE - CODE - CÓDIGO

**5132**

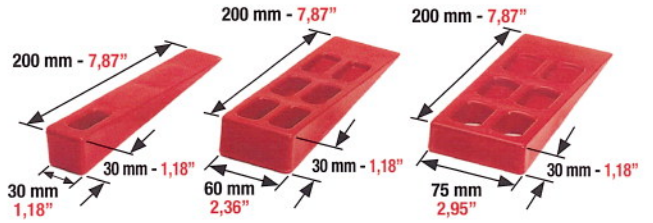

MISURE - SIZES - MEDIDAS  
mm 30 x 30 x 200  
mm 30 x 60 x 200  
mm 25 x 75 x 200

SET COMPOSTO DA 3 CUNEI DI DIVERSA MISURA  
SET OF 3 WEDGES OF DIFFERENT SIZES  
JUEGO COMPUESTO POR 3 CUÑAS DE TAMAÑO GRANDE

**SET "1" (STANDARD)**

CODICE - CODE - CÓDIGO

**5130**

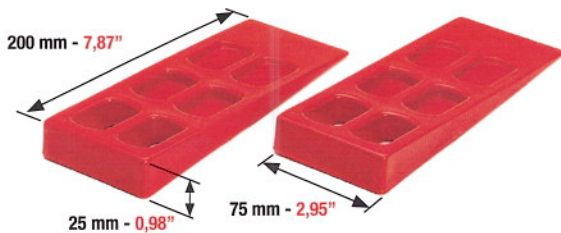

MISURE - SIZES - MEDIDAS  
mm 25 x 75 x 200

SET COMPOSTO DA 2 CUNEI DI MISURA GRANDE  
SET OF 2 LARGE WEDGES  
JUEGO COMPUESTO POR 2 CUÑAS DE TAMAÑO GRANDE

**SET "2"**

CODICE - CODE - CÓDIGO

**5135**

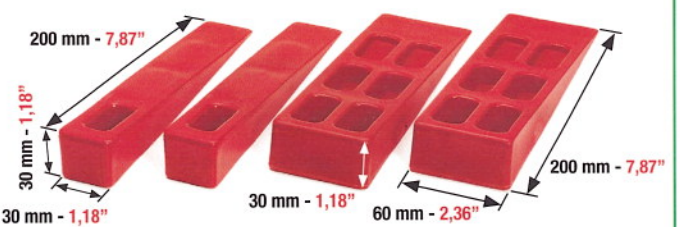

MISURE - SIZES - MEDIDAS  
mm 30 x 30 x 200  
mm 30 x 60 x 200

SET COMPOSTO DA 2 CUNEI PICCOLI + 2 MEDI  
SET OF 2 SMALL + 2 MEDIUM WEDGES  
JUEGO COMPUESTO POR 2 CUÑAS PEQUEÑAS + 2 MEDIAS

**SET "3"**

CODICE - CODE - CÓDIGO

**5140**



**TOP QUALITY**

**STANDARD SIZE**



SPATOLE IN PLASTICA PER INCHIOSTRO PER CALAMAI CON SENSORI "CPC"  
PLASTIC INK SPATULAS FOR "CPC" DUCT  
ESPATULAS DE PLASTICO PARA LA TINTA DE LOS TINTEROS CON SENSORES "CPC"

SCATOLE COMPOSTE DA 4 SPATOLE (GIALLA ROSSO BLU NERO)  
BOXES CONTAIN 4 SPATULAS (YELLOW RED BLUE BLACK)  
CAJA CON 4 ESPATULAS (AMARILLO ROJO AZUL NEGRO)

CODICE  
CODE - CÓDIGO

**5095**



**PERSONALIZZARE LE SPATOLE**  
LE NOSTRE SPATOLE POSSONO  
ESSERE PRODOTTE CON IL VOSTRO  
MARCHIO COMMERCIALE  
STAMPATO SUL MANICO.  
(RICHIEDETE MAGGIORI INFORMAZIONI)

**PERSONALISE THE SPATULAS**  
OUR SPATULAS CAN BE PRODUCED  
WITH YOUR COMPANY NAME  
AND LOGO PRINTED ON THE HANDLE  
(ASK FOR MORE DETAILS)

**PERSONALIZAR LAS ESPATULAS**  
TODAS NUESTRAS ESPATULAS  
SE PUEDEN SUMINISTRAR  
CON SU MARCA COMERCIAL  
IMPRESA EN EL MANGO  
(SOLICITE MAYOR INFORMACION)



NEW PACKAGING

**S/M** 74-CD 100 ST  
75-XL

**HD** 74 - 100 ST

**S/M** 102 CD  
105XL/106XL

**HD** 102 - 100 ST

**HD** 105 - 100 ST

**S/M** 52 □ | **S/M** 52 □  
**GTO** 52 □ | **CD** 100 ST □

**MO** 100 ST

**WEB** 8

**WEB** 16

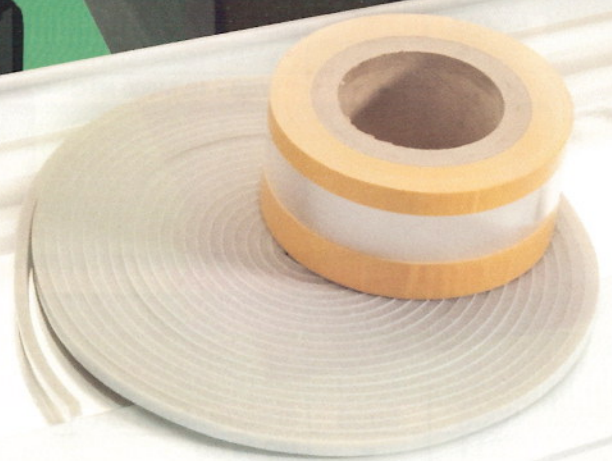

# SUPERFOIL®



**TOP QUALITY**

**COPRICALAMAIO D'ALTA QUALITÀ E DURATA**  
**HIGH QUALITY AND DURABILITY INK DUCT FOILS**  
**CUBRETINTEROS DE ALTA CALIDAD Y DURACION**

**QUALITÀ CERTIFICATA**  
**CERTIFIED QUALITY**  
**CALIDAD CERTIFICADA**

# SUPERFOIL® SUPERFOIL

STANDARD 0,19 MM 190 MY	FOR "UV" 0,25 MM 250 MY	MODELLO MACCHINE MACHINE MODEL MODELO DE MÁQUINA	LARGHEZZA WIDTH ANCHO MM	LARGHEZZA WIDTH ANCHO INCH	LUNGHEZZA LENGTH LONGITUD MM	LUNGHEZZA LENGTH LONGITUD INCH
5000	5046	QUICKMASTER 46 / PRINTMASTER 46	200	7.87"	358	14.09"
5007	5047-5048	SM 52 STANDARD - GTO 52	200	7.87"	548	21.57"
5010	5049	MO 65 STANDARD	200	7.87"	675	26.57"
5015	5050	SM 72/74 STANDARD	232	9.13"	775	30.51"
5020	5052	SPEEDMASTER 102 STANDARD	232	9.13"	1067	42.01"
5025	5051	SORD/SO	232	9.13"	935	36.81"
5030		* WEB - 8 (WITH FOAM)	260	10.24"	548	21.57"
5030A		WEB - 8 (WITHOUT FOAM)	260	10.24"	548	21.57"
5035		* WEB - 12 / MC 110 - HARRIS M1000 (WITH FOAM)	260	10.24"	740	29.13"
5035A		WEB - 12 / MC 110 - HARRIS M1000 (WITHOUT FOAM)	260	10.24"	740	29.13"
5037		* WEB - MC 130 - HARRIS M130 (WITH FOAM)	260	10.24"	994	39.13"
5037A		WEB - MC 130 - HARRIS M130 (WITHOUT FOAM)	260	10.24"	994	39.13"
5040		* WEB - 16 / HARRIS 600 (WITH FOAM)	260	10.24"	1002	39.45"
5040A		WEB - 16 / HARRIS 600 (WITHOUT FOAM)	260	10.24"	1002	39.45"
5042		** WEB - 16/M600 NTC - HARRIS M600 (WITH FOAM)	260	10.24"	1002	39.45"
5042A		** WEB - 16/M600 NTC - HARRIS M600 (WITH FOAM)	260	10.24"	1065	41.93"

## "STANDARD" SECTION

STANDARD 0,19 MM 190 MY	FOR "UV" 0,25 MM 250 MY	MODELLO MACCHINE MACHINE MODEL MODELO DE MÁQUINA	LARGHEZZA WIDTH ANCHO MM	LARGHEZZA WIDTH ANCHO INCH	LUNGHEZZA LENGTH LONGITUD MM	LUNGHEZZA LENGTH LONGITUD INCH
5008	5056	SPEEDMASTER 52 CD - 52 SX	196	7.72"	548	21.57"
5011	-	MO 65 CD	196	7.72"	675	26.57"
5016	5057	SPEEDMASTER 74 CD	228	8.98"	775	30.51"
5017	5062	SPEEDMASTER 75 XL	228	9.13"	775	30.51"
5018	5057A	SPEEDMASTER 74 SX	196	7.72"	775	30.51"
5022	5058	SPEEDMASTER 102 CD	228	8.98"	1067	42.01"
5023	5061	SPEEDMASTER 105 XL / 106 XL	228	8.98"	1067	42.01"
5024	5051A	SPEEDMASTER CS 92	228	8.98"	937	36.89"
5026	5066	SPEEDMASTER 145 XL	265	10.43"	1478	58.19"
5027	5067	SPEEDMASTER 162 XL	265	10.43"	1673	68.87"

## "NEW MODEL" SECTION

CONFEZIONE STANDARD: 100 PEZZI  
 STANDARD BOX: 100 PCS  
 CONFECCION ESTÁNDAR: 100 UNIDADES

\* CONFEZIONE WEB-8 / WEB-12 / WEB-MC130 / WEB-16: 50 PEZZI  
 \* BOX WEB-8 / WEB-12 / WEB-MC130 / WEB-16: 50 PCS  
 \* CONFECCION WEB-8 / WEB-12 / WEB-MC130 / WEB-16: 50 UNIDADES

\*\* CON PERFORAZIONE  
 \*\* WITH PERFORATION  
 \*\* CON PERFORACIÓN

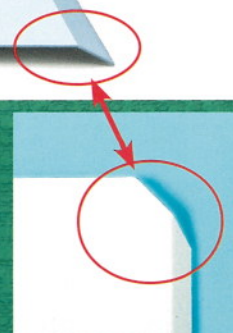

# INK DUCT END BLOCKS

SPALLE DI BLOCCAGGIO COPRICALAMAIO

RESPALDO DE BLOQUEO DEL CUBRETINTERO



**NEW!**



FOR HEIDELBERG SPEEDMASTER

145XL: 5137-A

**NEW!**

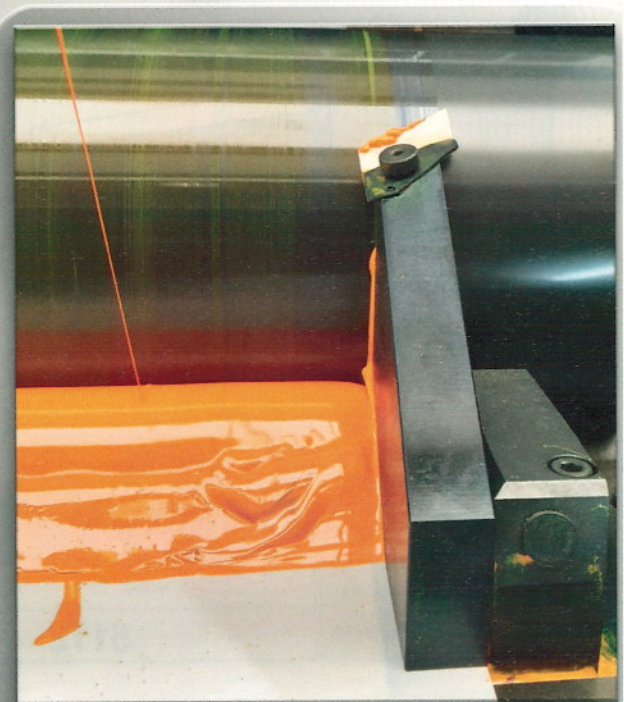



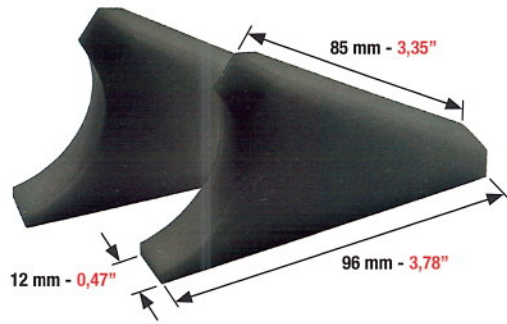

SPALLE DI BLOCCAGGIO COPRICALAMAIO PER:  
 INK DUCT END BLOCKS FOR:  
 RESPALDO DE BLOQUEO DEL CUBRETINTERO PARA:  
**HEIDELBERG QUICKMASTER 46**

CONFEZIONE: UNA COPPIA  
 PACKET: ONE PAIR  
 CONFECCIÓN: DOS UNIDADES

CODICE - CODE - CÓDIGO

**5107**

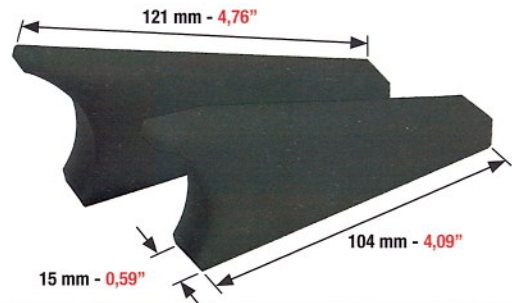

SPALLE DI BLOCCAGGIO COPRICALAMAIO PER:  
 INK DUCT END BLOCKS FOR:  
 RESPALDO DE BLOQUEO DEL CUBRETINTERO PARA:  
**HEIDELBERG QUICKMASTER 46-Di**

CONFEZIONE: UNA COPPIA  
 PACKET: ONE PAIR  
 CONFECCIÓN: DOS UNIDADES

CODICE - CODE - CÓDIGO

**5108**

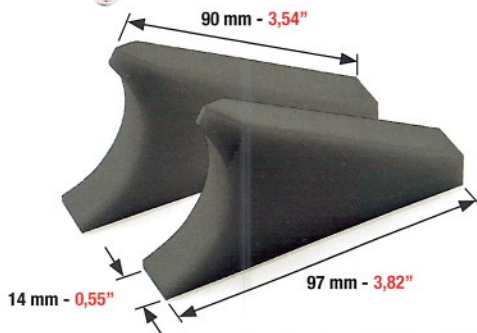

SPALLE DI BLOCCAGGIO COPRICALAMAIO PER:  
 INK DUCT END BLOCKS FOR:  
 RESPALDO DE BLOQUEO DEL CUBRETINTERO PARA:  
**HEIDELBERG GTO 52**  
 SENZA/WITHOUT/SIN: "CPTRONIC"

CONFEZIONE: UNA COPPIA  
 PACKET: ONE PAIR  
 CONFECCIÓN: DOS UNIDADES

CODICE - CODE - CÓDIGO

**5109**

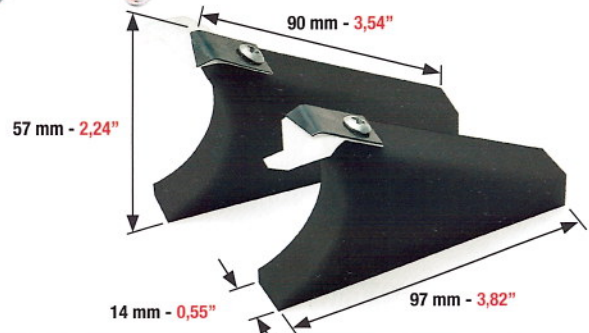

SPALLE DI BLOCCAGGIO COPRICALAMAIO COMPLETE PER:  
 COMPLETE INK DUCT END BLOCKS FOR:  
 RESPALDO COMPLETO DE BLOQUEO DEL CUBRETINTERO PARA:  
**HEIDELBERG GTO 52**  
 SENZA/WITHOUT/SIN: "CPTRONIC"

CONFEZIONE: UNA COPPIA  
 PACKET: ONE PAIR  
 CONFECCIÓN: DOS UNIDADES

CODICE - CODE - CÓDIGO

**5110**

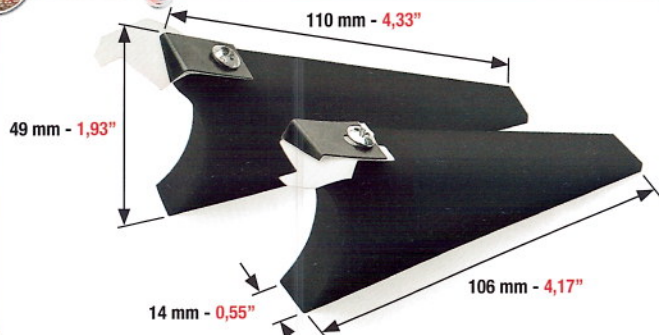

SPALLE DI BLOCCAGGIO COPRICALAMAIO COMPLETE PER:  
 COMPLETE INK DUCT END BLOCKS FOR:  
 RESPALDO COMPLETO DE BLOQUEO DEL CUBRETINTERO PARA:  
**HEIDELBERG GTO 52**  
 CON/WITH: "CPC" E "CPTRONIC"

CONFEZIONE: UNA COPPIA  
 PACKET: ONE PAIR  
 CONFECCIÓN: DOS UNIDADES

CODICE - CODE - CÓDIGO

**5112**

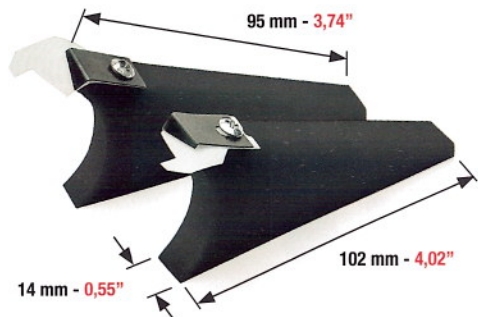

SPALLE DI BLOCCAGGIO COPRICALAMAIO PER:  
 INK DUCT END BLOCKS FOR:  
 RESPALDO DE BLOQUEO DEL CUBRETINTERO PARA:  
**HEIDELBERG SPEEDMASTER 52**  
 VECCHIO MODELLO - OLD MODEL - MODELO VIEJO (FINO AL/UP TO/HASTA EL 1998)

CONFEZIONE: UNA COPPIA  
 PACKET: ONE PAIR  
 CONFECCIÓN: DOS UNIDADES

CODICE - CODE - CÓDIGO

**5113**

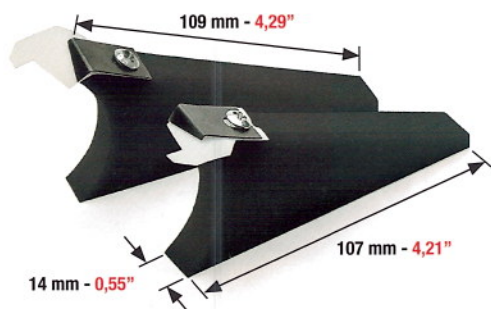

SPALLE DI BLOCCAGGIO COPRICALAMAIO COMPLETE PER:  
COMPLETE INK DUCT END BLOCKS FOR:  
RESPALDO COMPLETO DE BLOQUEO DEL CUBRETINTERO PARA:

**HEIDELBERG SPEEDMASTER 52**  
CON/WITH: "CPC" E "CPTRONIC"

CONFEZIONE: UNA COPPIA  
PACKET: ONE PAIR  
CONFECCIÓN: DOS UNIDADES

CODICE - CODE - CÓDIGO

**5111**

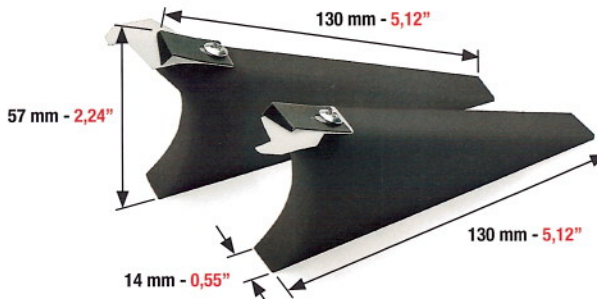

SPALLE DI BLOCCAGGIO COPRICALAMAIO COMPLETE PER:  
COMPLETE INK DUCT END BLOCKS FOR:  
RESPALDO COMPLETO DE BLOQUEO DEL CUBRETINTERO PARA:

**HEIDELBERG MO**

CONFEZIONE: UNA COPPIA  
PACKET: ONE PAIR  
CONFECCIÓN: DOS UNIDADES

CODICE - CODE - CÓDIGO

**5115**

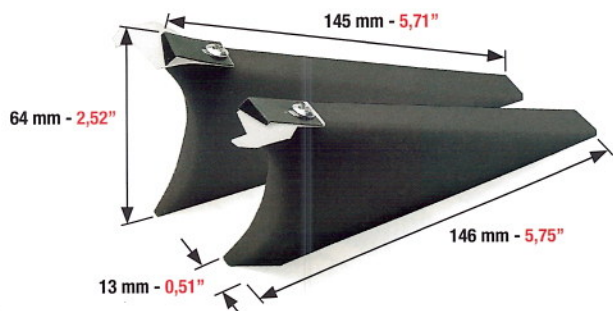

SPALLE DI BLOCCAGGIO COPRICALAMAIO COMPLETE PER:  
COMPLETE INK DUCT END BLOCKS FOR:  
RESPALDO COMPLETO DE BLOQUEO DEL CUBRETINTERO PARA:

**HEIDELBERG SPEEDMASTER 74**

CONFEZIONE: UNA COPPIA  
PACKET: ONE PAIR  
CONFECCIÓN: DOS UNIDADES

CODICE - CODE - CÓDIGO

**5120**

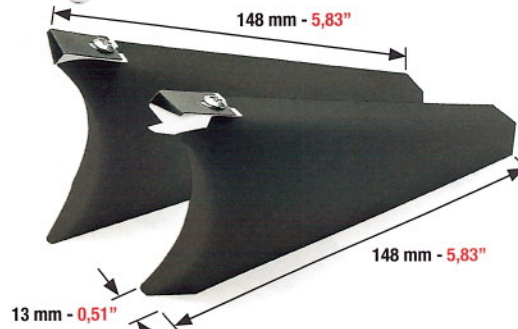

SPALLE DI BLOCCAGGIO COPRICALAMAIO COMPLETE PER:  
COMPLETE INK DUCT END BLOCKS FOR:  
RESPALDO COMPLETO DE BLOQUEO DEL CUBRETINTERO PARA:

**HEIDELBERG SPEEDMASTER 74 CD**  
**PRINTMASTER 74**

CONFEZIONE: UNA COPPIA  
PACKET: ONE PAIR  
CONFECCIÓN: DOS UNIDADES

CODICE - CODE - CÓDIGO

**5119**

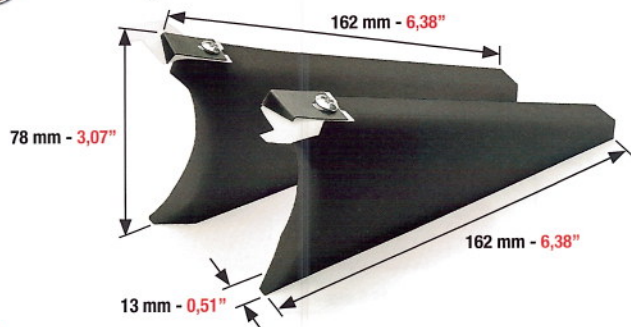

SPALLE DI BLOCCAGGIO COPRICALAMAIO COMPLETE PER:  
COMPLETE INK DUCT END BLOCKS FOR:  
RESPALDO COMPLETO DE BLOQUEO DEL CUBRETINTERO PARA:

**HEIDELBERG**  
**SPEEDMASTER 72/75 XL/102/102 CD**

CONFEZIONE: UNA COPPIA  
PACKET: ONE PAIR  
CONFECCIÓN: DOS UNIDADES

CODICE - CODE - CÓDIGO

**5125**

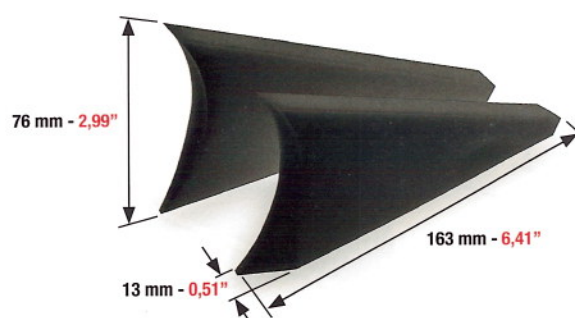

SPALLE DI BLOCCAGGIO COPRICALAMAIO PER:  
INK DUCT BLOCKS FOR:  
RESPALDO DE BLOQUEO DEL CUBRETINTERO PARA:

**HEIDELBERG SPEEDMASTER 105 XL/106 XL**

CONFEZIONE: UNA COPPIA  
PACKET: ONE PAIR  
CONFECCIÓN: DOS UNIDADES

CODICE - CODE - CÓDIGO

**5136**

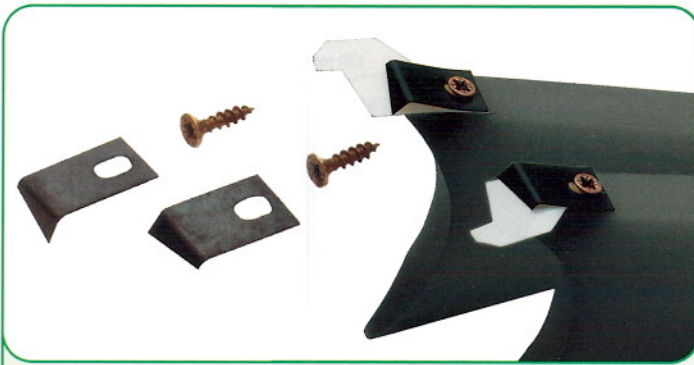

**PIASTRINE BLOCCA RASCHIETTO COMPLETE DI VITI**  
**SCRAPER HOLDER PLATE COMPLETE WITH SCREWS**  
**PLACA FIJADORA DEL RASCADOR CON TORNILLO**

CONFEZIONE DA 2 PEZZI (DESTRA E SINISTRA)  
 PACKETS OF 2 PIECES (RIGHT AND LEFT)  
 CONFECCIÓN DE 2 PIEZAS (DERECHA E IZQUIERDA)

CODICE - CODE - CÓDIGO

**5126**

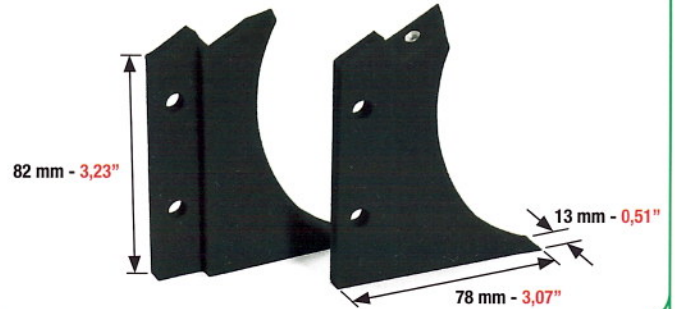

**SPALLE DI BLOCCAGGIO COPRICALAMAIO PER:**  
**INK DUCT END BLOCKS FOR:**  
**RESPALDO DE BLOQUEO DEL CUBRETINTERO PARA:**

**HEIDELBERG WEB 8/12/16**

CONFEZIONE: UNA COPPIA  
 PACKET: ONE PAIR  
 CONFECCIÓN: DOS UNIDADES

CODICE - CODE - CÓDIGO

**5131**

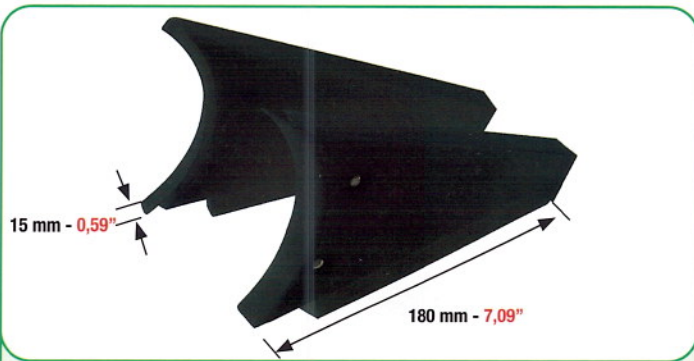

**SPALLE DI BLOCCAGGIO COPRICALAMAIO PER:**  
**INK DUCT END BLOCKS FOR:**  
**RESPALDO DE BLOQUEO DEL CUBRETINTERO PARA:**

**HARRIS GOSS M600**

CONFEZIONE: UNA COPPIA  
 PACKET: ONE PAIR  
 CONFECCIÓN: DOS UNIDADES

CODICE - CODE - CÓDIGO

**5131-A**

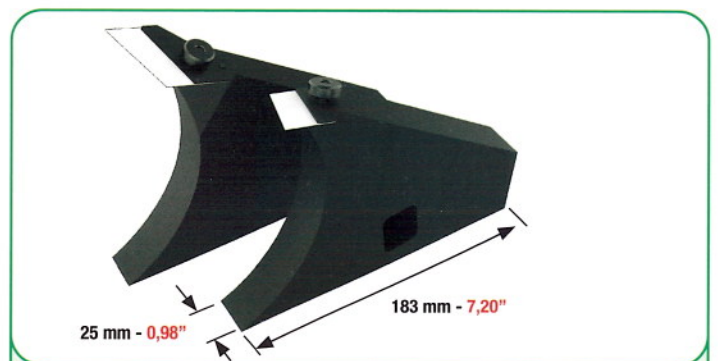

**SPALLE DI BLOCCAGGIO COPRICALAMAIO COMPLETE PER:**  
**COMPLETE INK DUCT END BLOCKS FOR:**  
**RESPALDO COMPLETO DE BLOQUEO DEL CUBRETINTERO PARA:**

**HEIDELBERG SPEEDMASTER 145XL**  
**NEW MODEL**

CONFEZIONE: UNA COPPIA  
 PACKET: ONE PAIR  
 CONFECCIÓN: DOS UNIDADES

CODICE - CODE - CÓDIGO

**5137-A**

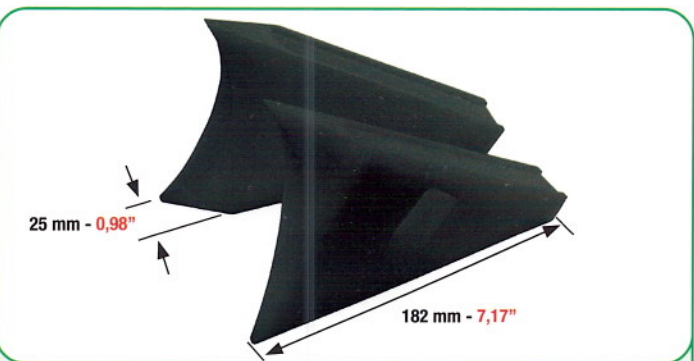

**SPALLE DI BLOCCAGGIO COPRICALAMAIO COMPLETE PER:**  
**COMPLETE INK DUCT END BLOCKS FOR:**  
**RESPALDO COMPLETO DE BLOQUEO DEL CUBRETINTERO PARA:**

**HEIDELBERG SPEEDMASTER 162XL**

CONFEZIONE: UNA COPPIA  
 PACKET: ONE PAIR  
 CONFECCIÓN: DOS UNIDADES

CODICE - CODE - CÓDIGO

**5137**

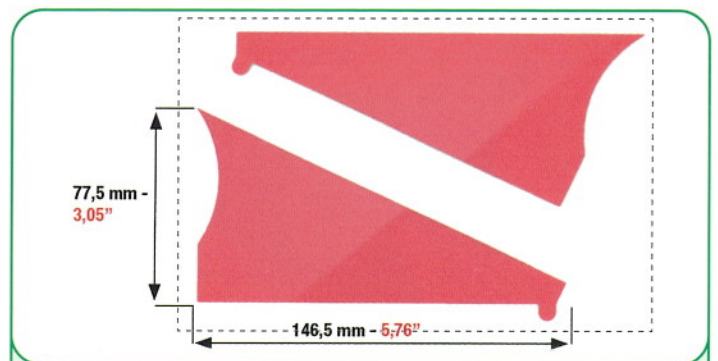

**ADESIVI PER SPALLE DI BLOCCAGGIO COPRICALAMAIO PER:**  
**ADHESIVES FOR INK DUCT END BLOCKS FOR:**  
**ADHESIVOS PARA RESPALDO DE BLOQUEO DEL CUBRETINTERO PARA:**

**HEIDELBERG SPEEDMASTER HD 102**

CONFEZIONE: UNA COPPIA  
 PACKET: ONE PAIR  
 CONFECCIÓN: DOS UNIDADES

CODICE - CODE - CÓDIGO

**5125-A**

**NUOVA QUALITÀ  
NUOVI PREZZI  
NEW QUALITY  
NEW PRICES  
NUEVA CALIDAD  
NUEVOS PRECIOS**

# SUPER BLADES®

**LAME CALAMAIO / LAME CALAMAIO A SETTORI  
INK BLADES / INK BLADES WITH SEGMENT  
REGLETAS DE TINTERO / REGLETAS DE TINTERO SEGMENTADAS**



## LAME CALAMAIO: REGOLATRICI DEL FLUSSO DI INCHIOSTRO ATTRAVERSO IL CALAMAIO AL RULLO CALAMAIO

Le nostre lame calamaio con e senza segmento vengono prodotte con l'utilizzo dei migliori acciai attraverso avanzatissimi procedimenti produttivi finalizzati a garantire uno standard qualitativo molto elevato. Disponibili per tutti i modelli "Heidelberg".



## INK BLADES: REGULATORS OF THE INK FLOW THROUGH THE INK DUCT TO THE DUCT ROLLER

Our ink blades, with and without segments, are produced using the best quality steels by means of extremely advanced production procedures to guarantee a very high quality standard. Available for all "Heidelberg" models.



## REGLETA DEL TINTERO, REGULADORA DEL FLUJO DE LA TINTA DESDE EL TINTERO AL RODILLO ENTINTADOR

En nuestras regletas de tintero, con y sin segmento, se utiliza para su producción el mejor acero, fabricado a través de avanzadísimos procedimientos productivos de acabado que garantizan un estándar qualitativo muy elevado. Disponibles para todos los modelos "Heidelberg".

## SUPER BLADES® HEIDELBERG SENZA SEGMENTO - WITHOUT SEGMENT - SIN SEGMENTO

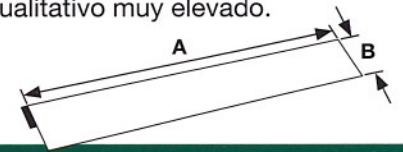

CODICE CODE CÓDIGO	DESCRIZIONE - DESCRIPTION - DESCRIPCIÓN	MISURE - SIZES - MEDIDAS			
		A		B	
		mm	inch	mm	inch
11000	INK BLADE - STELLA PICCOLA / PLATEN "T" - 26X38 -	375	14,76"	101	3,98"
11002	INK BLADE - STELLA GRANDE / PLATEN "GT" - 32X46 -	480	18,90"	101	3,98"
11004	INK BLADE QUICKMASTER	336	13,23"	71	2,80"
11006	INK BLADE GTO 46	452	17,80"	85	3,35"
11008	INK BLADE GTO 52	512	20,16"	94	3,70"
11009	INK BLADE SPEEDMASTER 52	520	20,47"	100	3,94"
11010	INK BLADE MO	662	26,06"	129	5,08"
11012	INK BLADE KOR / KORA	580	22,83"	101	3,98"
11014	INK BLADE KORD 62	630	24,80"	101	3,98"
11016	INK BLADE KORD 64	670	26,38"	101	3,98"
11018	INK BLADE KORS 72	740	29,13"	101	3,98"
11020	INK BLADE SORM / SPEEDMASTER 72	730	28,74"	120	4,65"
11021	INK BLADE SORM / SPEEDMASTER 72	730	28,74"	175	6,89"
11022	INK BLADE SORD	900	35,43"	118	4,65"
11023	INK BLADE SORD	900	35,43"	175	6,89"
11024	INK BLADE SORS / SPEEDMASTER 102	1030	40,55"	175	6,89"

## SUPER BLADES® HEIDELBERG CON SEGMENTO - WITH SEGMENT - CON SEGMENTO

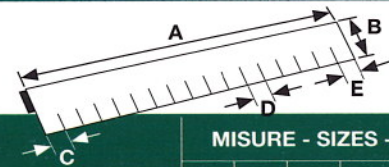

CODICE CODE CÓDIGO	DESCRIZIONE - DESCRIPTION - DESCRIPCIÓN	MISURE - SIZES - MEDIDAS					SEGMENTI SEGMENTS SEGMENTOS
		A mm	B mm	C mm	D mm	E mm	
11140	INK BLADE GTO 46	452	85	31,5	32,5	31,5	14
11142	INK BLADE GTO 52	512	94	28,5	32,5	28,5	16
11143	INK BLADE SPEEDMASTER 52	520	100	32,5	32,5	32,5	16
11145	INK BLADE MO	662	129	39	32,5	39	20
11150	INK BLADE SORM / SPEEDMASTER 72	730	175	24	32,5	24	23
11155	INK BLADE SPEEDMASTER 74 VECCHIO MODELLO - OLD MODEL - MODELO VIEJO da serie/from series/de la serie 620061 a/to/a 620587	748	135	32,5	32,5	32,5	23
11156	INK BLADE SPEEDMASTER 74 NUOVO MODELLO - NEW MODEL - MODELO NUEVO - oltre serie/from series/a partir de la serie 620588	748	135	32,5	32,5	32,5	23
11158	INK BLADE SORD	900	118	27,5	32,5	27,5	28
11159	INK BLADE SORD	900	175	27,5	32,5	27,5	28
11160	INK BLADE SORS / SPEEDMASTER 102	1030	175	27,5	32,5	27,5	32

**PER MAGGIORI INFORMAZIONI FATE RICHIESTA DEL LISTINO PREZZI RELATIVO ALLE NOSTRE "SUPER BLADES®"  
FOR FURTHER INFORMATION PLEASE REQUEST THE PRICE LIST FOR OUR "SUPER BLADES®"  
PARA MAYOR INFORMACIÓN SOLICITE LA TARIFA DE PRECIOS CORRESPONDIENTE A NUESTRAS "SUPER BLADES®"**

**Standard**

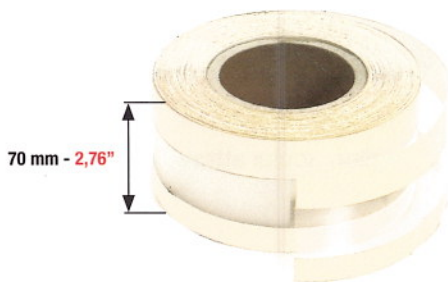

70 mm - 2,76"

"STANDARD" - "STANDARD" - "ESTÁNDAR"

BIADESIVO A DUE FASCE COPRI-SETTORE PER:  
DOUBLE STRIP BI-ADHESIVE UNDERLINER FOIL FOR:  
BIADHESIVO A DOS CARAS CUBRE-ZONAS PARA:

**HEIDELBERG SPEEDMASTER 52/72/74/102**  
TUTTI I MODELLI - ALL MODELS - TODOS LOS MODELOS

ROTTOLI DA 25 MT  
ROLLS OF 25 M (22,86 YDS.)  
ROLLOS DE 25 METROS

CODICE - CODE - CÓDIGO

**5074**

**Strong**

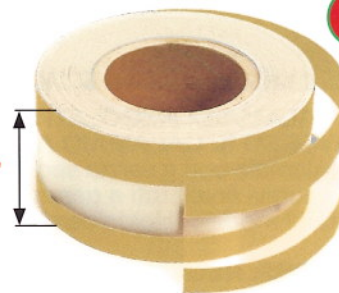

70 mm - 2,76"

"FORTE" CON TESSUTO - "STRONG" WITH CLOTH STRIP - "FUERTE" CON TELA

BIADESIVO A DUE FASCE COPRI-SETTORE PER:  
DOUBLE STRIP BI-ADHESIVE UNDERLINER FOIL FOR:  
BIADHESIVO A DOS CARAS CUBRE-ZONAS PARA:

**HEIDELBERG SPEEDMASTER 52/72/74/102**  
TUTTI I MODELLI - ALL MODELS - TODOS LOS MODELOS

ROTTOLI DA 25 MT  
ROLLS OF 25 M (22,86 YDS.)  
ROLLOS DE 25 METROS

CODICE - CODE - CÓDIGO

**5075**

**NEW**

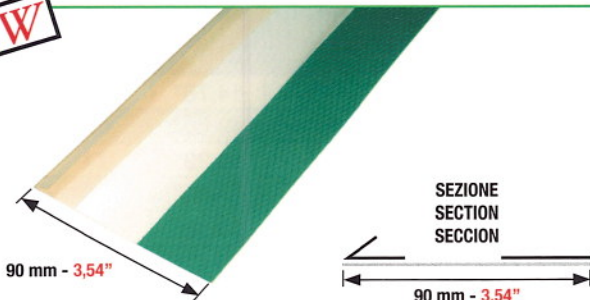

90 mm - 3,54"

SEZIONE  
SECTION  
SECCION

90 mm - 3,54"

SCATOLE DA 12 PEZZI - BOX OF 12 PCS - CAJA DE 12 UNIDADES

BIADESIVO SPECIALE COPRI-SETTORE CON SAGOMATURA PER:  
SPECIAL SHAPED BI-ADHESIVE UNDERLINER FOIL FOR:  
BIADHESIVO ESPECIAL CUBRE-ZONAS CON MOLDURAS PARA:

**SPEEDMASTER 52 CD/74 CD/75 XL**  
**SPEEDMASTER 102 CD NEW/105 XL/142XL/162 XL**

CODICE - CODE - CÓDIGO	SPEEDMASTER	LUNGHEZZA - LENGTH - LONGITUD	INCH
5071	52 - CD	mm 550	21,65"
5072	74 CD / 75 XL	mm 777	30,59"
5073	102 CD / 105 XL	mm 1070	42,13"
5077	145 XL	mm 1478	58,19"
5078	162 XL	mm 1676	65,98"

**Standard**



90 mm - 3,54"

BIADESIVO COPRISETTORE A DUE FASCE PER:  
BI-ADHESIVE UNDERLINER PROTECTIVE FOIL FOR:  
BIADHESIVO CUBRE-ZONAS A DOS CARAS PARA:

**HEIDELBERG WEB 8/WEB 12/WEB 16**  
**HARRIS M1000/M130/M600**

ROTTOLI DA 25 MT  
ROLLS OF 25 M (22,86 YDS.)  
ROLLOS DE 25 METROS

CODICE - CODE - CÓDIGO

**5076**

**5082**

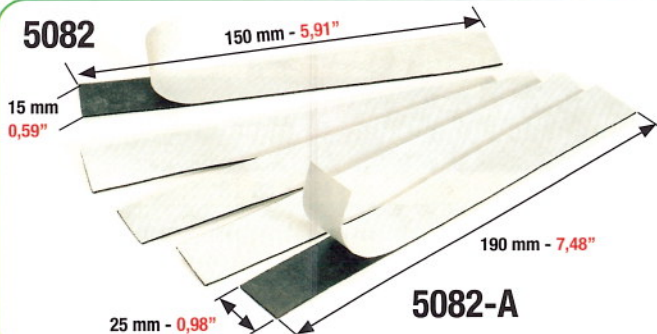

150 mm - 5,91"

15 mm  
0,59"

190 mm - 7,48"

**5082-A**

25 mm - 0,98"

STRISCE BIADESIVE PER SPALLE LATERALI  
BI-ADHESIVE DUCT INSULATING STRIPS  
TIRAS BIADHESIVAS PARA APOYOS LATERALES

CONFEZIONE DA 10 PEZZI  
10 PCS PACKET  
CONFECCION DE 10 UNIDADES

CODICE - CODE - CÓDIGO

**5082**

15 mm x 150 mm

**5082-A**

25 mm x 190 mm



BIADESIVO "FORTE" (CON TESSUTO) PER SPALLE LATERALI  
"STRONG" BI-ADHESIVE FOR INK DUCT BLOCKS  
BIADHESIVO "FUERTE" CON TELA PARA APOYOS LATERALES DE CUBRETINTEROS

ROTTOLI DA 25/50 MT  
ROLLS OF 25/50 MT  
ROLLOS DE 25/50 MT

CODICE - CODE - CÓDIGO

**5080**

15 mm x 25 mt

**5080-A**

25 mm x 25 mt

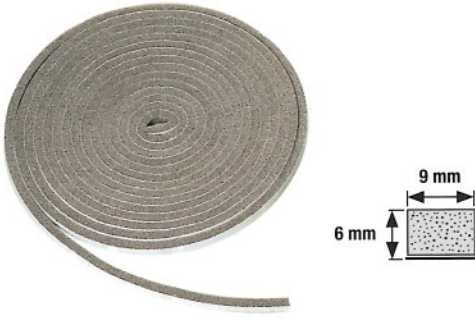

SCHIUMA ADESIVA PER COPRICALAMAIO  
TESAMOL TAPE FOR INK DUCT FOILS  
ESPUMA ADHESIVA PARA CUBRETINTEROS

ROTTOLI DA 10 MT  
ROLLS OF 10 M (9.144 YDS.)  
ROLLOS DA 10 METROS

CODICE - CODE - CÓDIGO

**5070**

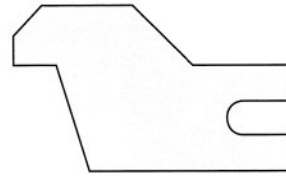

**MISURA REALE - REAL SIZE - MEDIDA REAL**

RASCHIETTO PULITORE LATERALE PER RULLO CALAMAIO PER:  
LATERAL CLEANING SCRAPER FOR INK DUCT ROLLER FOR:  
RASCADOR LIMPIADOR LATERAL PARA RODILLO DEL TINTERO PARA:

**QUICKMASTER/GT052/SORD/SO/MO  
SPEEDMASTER 52/72/74/102**

CONFEZIONE DA 50 PEZZI  
50 PCS PACKET  
CONFECCIONES DE 50 PIEZAS

CODICE - CODE - CÓDIGO

**5085**

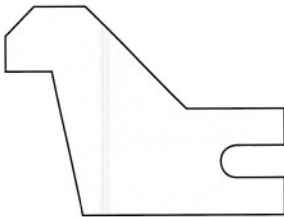

**MISURA REALE - REAL SIZE - MEDIDA REAL**

RASCHIETTO PULITORE LATERALE PER RULLO CALAMAIO PER:  
LATERAL CLEANING SCRAPER FOR INK DUCT ROLLER FOR:  
RASCADOR LIMPIADOR LATERAL PARA RODILLO DEL TINTERO PARA:

**HEIDELBERG SPEEDMASTER 102 CD NEW  
SPEEDMASTER 105 XL**

CONFEZIONE DA 50 PEZZI  
50 PCS PACKET  
CONFECCIONES DE 50 PIEZAS

CODICE - CODE - CÓDIGO

**5086**

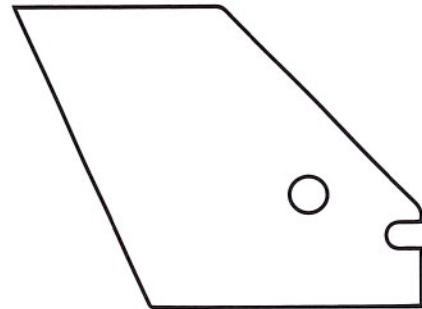

**MISURA REALE - REAL SIZE - MEDIDA REAL**

RASCHIETTO PULITORE LATERALE PER RULLO CALAMAIO PER:  
LATERAL CLEANING SCRAPER FOR INK DUCT ROLLER FOR:  
RASCADOR LIMPIADOR LATERAL PARA RODILLO DEL TINTERO PARA:

**HEIDELBERG SPEEDMASTER 145XL/162XL**

CONFEZIONE DA 50 PEZZI  
50 PCS PACKET  
CONFECCIONES DE 50 PIEZAS

CODICE - CODE - CÓDIGO

**5185-A**

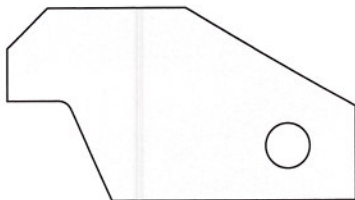

**MISURA REALE - REAL SIZE - MEDIDA REAL**

RASCHIETTO PULITORE LATERALE PER RULLO CALAMAIO PER:  
LATERAL CLEANING SCRAPER FOR INK DUCT ROLLER FOR:  
RASCADOR LIMPIADOR LATERAL PARA RODILLO DEL TINTERO PARA:

**HEIDELBERG/HARRIS M110/M600**

CONFEZIONE DA 50 PEZZI  
50 PCS PACKET  
CONFECCIONES DE 50 PIEZAS

CODICE - CODE - CÓDIGO

**5087**

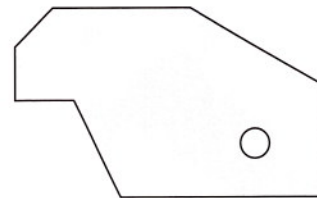

**MISURA REALE - REAL SIZE - MEDIDA REAL**

RASCHIETTO PULITORE LATERALE PER RULLO CALAMAIO PER:  
LATERAL CLEANING SCRAPER FOR INK DUCT ROLLER FOR:  
RASCADOR LIMPIADOR LATERAL PARA RODILLO DEL TINTERO PARA:

**HEIDELBERG WEB 8/WEB 16**

CONFEZIONE DA 50 PEZZI  
50 PCS PACKET  
CONFECCIONES DE 50 PIEZAS

CODICE - CODE - CÓDIGO

**5090**



# ROYAL CLEANING PRODUCTS®



**Economic**

10620 - 1000 cc

10625 - 1000 cc

10610 - 500 cc

10615 - 500 cc

BOTTIGLIE DI LAVAGGIO ECONOMICHE  
CON BECCUCCIO DIRITTO O CURVO DA 500 E 1000 CC  
ECONOMICAL WASH BOTTLES  
WITH STRAIGHT OR BENT SPOUT - 500 CC AND 1000 CC  
BOTELLA DE LAVADO ECONOMICA  
CON TUBO RECTO O CURVADO DE 500 Y 1000 CC

CODICE - CODE - CÓDIGO

10610 / 10615

10620 / 10625

**Top Quality**

BOTTIGLIE DI LAVAGGIO DI ALTA QUALITÀ E RESISTENZA  
AI VARI SOLVENTI - 1000 CC  
HIGH QUALITY SOLVENT-RESISTANT WASH BOTTLES - 1000 CC  
BOTELLA DE LAVADO DE ALTA CALIDAD Y RESISTENCIA  
A SOLVENTES VARIOS DE 1000 CC

CODICE - CODE - CÓDIGO

10600

ESCLUSIVA MONDIALE  
WORLDWIDE EXCLUSIVE  
EXCLUSIVA MONDIAL



CONFEZIONE DA 12 PEZZI  
PACKET OF 12 PCS  
CONFECCION DE 12 UNIDADES



## SUPER GLOVES PROFESSIONAL

GUANTI SPECIALI IN NITRILE DI ALTISSIMA QUALITÀ RESISTENTI AGLI ACIDI ED AI SOLVENTI  
SPECIAL HIGH QUALITY NITRILE GLOVES RESISTANT TO ACIDS AND SOLVENTS  
GUANTES ESPECIALES DE NITRILLO DE ALTISIMA CALIDAD, RESISTENTES A LOS ACIDOS Y SOLVENTES

CODICE CODE - CÓDIGO	MISURA - SIZE - MEDIDA
10660	8
10662	9
10664	10

TOP QUALITY  
ORIGINAL



## ROYAL SPONGES

SPUGNE PRESSATE DI ALTISSIMA QUALITÀ  
TOP QUALITY COMPRESSED SPONGES  
ESPONJAS PRENSADA DE ALTISIMA CALIDAD

CONFEZIONE DA 10 PEZZI PACKET OF 10 PCS CONFECCION DE 10 UNIDADES	DIMENSIONI - SIZE - TAMAÑO	CODICE - CODE - CÓDIGO
	140 x 95 x 35 mm	10651
	140 x 95 x 32 mm	10652

NO  
CHINESE  
PRODUCTS

## SUPER SCRUBBER

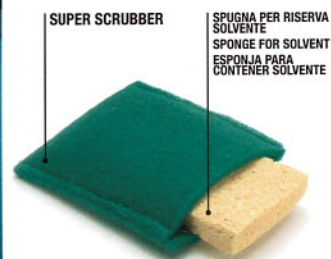
**Strong**

FIBRA ABRASIVA SPECIALE PER LA PULIZIA IN PROFONDITÀ DI TESSUTI GOMMATI MOLTO SPORCHI COMPLETA DI SPUGNA PER IL SOLVENTE  
SPECIAL ABRASIVE FIBRE FOR DEEP CLEANING OF VERY DIRTY PRINTING BLANKETS, COMPLETE WITH SPONGE FOR SOLVENT  
FIBRA ABRASIVA ESPECIAL PARA LA LIMPIEZA EN PROFUNDIDAD DE CAUCHOS MUY SUCIOS, CON ESPONJA PARA EL SOLVENTE

ORDINE MINIMO 4 PEZZI  
MINIMUM ORDER 4 PCS  
PEDIDO MINIMO 4 PIEZAS

CODICE - CODE - CÓDIGO

10640



**SUPER SCRUBBER**  
*white*



**Soft**

SUPER SCRUBBER *white*

SPUGNA PER RISERVA SOLVENTE  
SPONGE FOR SOLVENT  
ESPONJA PARA CONTENEDOR SOLVENTE

SPECIALE FIBRA SINTETICA NON ABRASIVA PER LA PULIZIA OTTIMALE DI TESSUTI GOMMATI MOLTO SPORCHI COMPLETA DI SPUGNA PER IL SOLVENTE  
SPECIAL SYNTHETIC NON-ABRASIVE FIBRE FOR THOROUGH CLEANING OF VERY DIRTY PRINTING BLANKETS, COMPLETE WITH SPONGE FOR SOLVENT  
FIBRA SINTETICA ESPECIAL NO ABRASIVA PARA LA PERFECTA LIMPIEZA DE CAUCHOS MUY SUCIOS, CON ESPONJA PARA EL SOLVENTE

ORDINE MINIMO 4 PEZZI MINIMUM ORDER 4 PCS PEDIDO MINIMO 4 PIEZAS	CODICE - CODE - CÓDIGO <b>10644</b>
--	--

**DUAL SUPER SCRUBBER**



**NEW**

1/2 Strong  
1/2 Soft

SUPER SCRUBBER SOFT

SUPER SCRUBBER STRONG

SPUGNA PER RISERVA SOLVENTE  
SPONGE FOR SOLVENT  
ESPONJA PARA CONTENEDOR SOLVENTE

FIBRA ABRASIVA (STRONG) E SPECIALE FIBRA SINTETICA NON ABRASIVA (SOFT) PER PULIZIA OTTIMALE DI TESSUTI GOMMATI MOLTO SPORCHI COMPLETA DI SPUGNA PER IL SOLVENTE  
ABRASIVE FIBRE (STRONG) AND SPECIAL SYNTHETIC NON-ABRASIVE FIBRE (SOFT) FOR THOROUGH CLEANING OF VERY DIRTY PRINTING BLANKETS COMPLETE WITH SPONGE FOR SOLVENT  
FIBRA ABRASIVA (STRONG) Y FIBRA SINTETICA ESPECIAL NO ABRASIVA (SOFT) PARA LA PERFECTA LIMPIEZA DE CAUCHOS MUY SUCIOS CON ESPONJA PARA EL SOLVENTE

ORDINE MINIMO 4 PEZZI MINIMUM ORDER 4 PCS PEDIDO MINIMO 4 PIEZAS	CODICE - CODE - CÓDIGO <b>10640-A</b>
--	--

**COMPACT SCRUB**



**Strong**

FIBRA ABRASIVA SPECIALE PER LA PULIZIA IN PROFONDITÀ DI TESSUTI GOMMATI MOLTO SPORCHI  
SPECIAL ABRASIVE FIBRE FOR DEEP CLEANING OF VERY DIRTY PRINTING BLANKETS  
FIBRA ABRASIVA ESPECIAL PARA LA LIMPIEZA EN PROFUNDIDAD DE CAUCHOS MUY SUCIOS

ORDINE MINIMO 4 PEZZI MINIMUM ORDER 4 PCS PEDIDO MINIMO 4 PIEZAS	CODICE - CODE - CÓDIGO <b>10642</b>
--	--

**COMPACT SCRUB**  
*white*



**Soft**

SPECIALE FIBRA SINTETICA NON ABRASIVA PER LA PULIZIA OTTIMALE DI TESSUTI GOMMATI MOLTO SPORCHI  
SPECIAL SYNTHETIC NON-ABRASIVE FIBRE FOR THOROUGH CLEANING OF VERY DIRTY PRINTING BLANKETS  
FIBRA SINTETICA ESPECIAL NO ABRASIVA PARA LA PERFECTA LIMPIEZA DE CAUCHOS MUY SUCIOS

ORDINE MINIMO 4 PEZZI MINIMUM ORDER 4 PCS PEDIDO MINIMO 4 PIEZAS	CODICE - CODE - CÓDIGO <b>10646</b>
--	--

**DUAL COMPACT SCRUB**



**NEW**

1/2 Strong  
1/2 Soft

SUPER SCRUBBER SOFT

SUPER SCRUBBER STRONG

FIBRA ABRASIVA (STRONG) E SPECIALE FIBRA SINTETICA NON ABRASIVA (SOFT) PER PULIZIA OTTIMALE DI TESSUTI GOMMATI MOLTO SPORCHI  
ABRASIVE FIBRE (STRONG) AND SPECIAL SYNTHETIC NON-ABRASIVE FIBRE (SOFT) FOR THOROUGH CLEANING OF VERY DIRTY PRINTING BLANKETS  
FIBRA ABRASIVA (STRONG) Y FIBRA SINTETICA ESPECIAL NO ABRASIVA (SOFT) PARA LA PERFECTA LIMPIEZA DE CAUCHOS MUY SUCIOS

ORDINE MINIMO 4 PEZZI MINIMUM ORDER 4 PCS PEDIDO MINIMO 4 PIEZAS	CODICE - CODE - CÓDIGO <b>10646-A</b>
--	--

**SIMPLE SCRUBBER**





**Strong**

SPECIALE SPUGNA REALIZZATA DA UN LATO CON UNA FIBRA SINTETICA ABRASIVA E DA UN LATO CON VERA SPUGNA IN CELLULOSA. SPECIFICA PER LA PULIZIA IN PROFONDITÀ DI TESSUTI GOMMATI MOLTO SPORCHI.  
SPECIAL SPONGE MADE ON ONE SIDE WITH SYNTHETIC ABRASIVE FIBRE AND ON THE OTHER WITH REAL SPONGE IN CELLULOSE. SPECIFIC FOR DEEP CLEANING OF VERY DIRTY PRINTING BLANKETS.  
ESPONJA ESPECIAL REALIZADA DE UN LATO CON FIBRA SINTETICA ABRASIVA Y DEL OTRO CON ESPONJA VERDADERA IN CELLULOSA. ESPECIFICA PARA LA LIMPIEZA EN PROFUNDIDAD DE CAUCHOS MUY SUCIOS.

ORDINE MINIMO 4 PEZZI MINIMUM ORDER 4 PCS PEDIDO MINIMO 4 PIEZAS	CODICE - CODE - CÓDIGO <b>10647</b>
--	--

## SIMPLE SCRUBBER

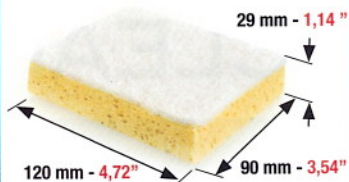
Soft



SPECIALE SPUGNA REALIZZATA DA UN LATO CON UNA FIBRA SINTETICA NON ABRASIVA E DA UN LATO CON VERA SPUGNA IN CELLULOSA. SPECIFICA PER LA PULIZIA OTTIMALE DI TESSUTI GOMMATI MOLTO SPORCHI.

SPECIAL SPONGE MADE ON ONE SIDE WITH SYNTHETIC NON-ABRASIVE FIBRE AND ON THE OTHER WITH REAL SPONGE IN CELLULOSE. SPECIFIC FOR PERFECT CLEANING OF VERY DIRTY PRINTING BLANKETS.

ESPONJA ESPECIAL REALIZADA DE UN LADO CON FIBRA SINTETICA NO ABRASIVA Y DEL OTRO CON ESPONJA VERDADERA IN CELLULOSA. ESPECIFICA PARA LA PERFECTA LIMPIEZA DE CAUCHOS MUY SUCIOS.

ORDINE MINIMO 4 PEZZI  
MINIMUM ORDER 4 PCS  
PEDIDO MINIMO 4 PIEZAS

CODICE - CODE - CÓDIGO

**10648**

## SIMPLE SANDWICH SCRUBBER

1/2 Strong  
1/2 Soft

**NEW**

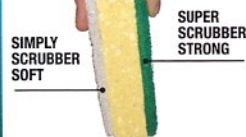

DA UN LATO ABRASIVA (STRONG) E DA UN LATO NON ABRASIVA (SOFT), IN MEZZO SPUGNA IN CELLULOSA, PER PULIZIA OTTIMALE DI TESSUTI GOMMATI MOLTO SPORCHI

ON ONE SIDE ABRASIVE (STRONG) AND ON ONE SIDE NON-ABRASIVE (SOFT), IN THE MIDDLE SPONGE IN CELLULOSE, FOR PERFECT CLEANING OF VERY DIRTY PRINTING BLANKETS

DE UN LADO ABRASIVA (STRONG) Y DE OTRO NO ABRASIVA (SOFT), EN EL MEDIO ESPONJA IN CELLULOSA, PARA LA PERFECTA LIMPIEZA DE CAUCHOS MUY SUCIOS

ORDINE MINIMO 4 PEZZI  
MINIMUM ORDER 4 PCS  
PEDIDO MINIMO 4 PIEZAS

CODICE - CODE - CÓDIGO

**10648-A**

**NEW**

# ALL-TEX UNIVERSAL



CODE 27.22381

ALL-TEX® UNIVERSAL

(85gr/sqm)

1 BOX = 300 CLOTHS

CLOTH SIZE: 400MM X 310MM



**THE NEW MICRO-PERFORATED CLOTH  
FOR THE CLEANING OF ALL SURFACES !!**

**IL NUOVO PANNO MICROFORATO  
PER LA PULIZIA DI TUTTE LE SUPERFICI !!**

**EL NUEVO TEJIDO MICRO PERFORADO  
PARA LIMPIAR TODAS LAS SUPERFICIES ¡!**

# WASHCLOTH PRODUCTS FOR MANUAL CLEANING



## FOILTEX PROGRAMME



**CODE 27.22384** **FOILTEX® BLU-TEX VERSION\*** (68gr/sqm)  
and **BLU-TEX MARINE VERSION** (68gr/sqm)

**CODE 27.22382** **FOILTEX® WHITE-TEX VERSION** (68gr/sqm)

**CODE 27.22386** **FOILTEX® SONTARA VERSION** (68gr/sqm)

**1 BOX = 500 CLOTHS**  
**CLOTH SIZE: 400MM X 310MM**  
**\* STANDARD = MOST FREQUENTLY SOLD**



**CODE 27.22389** **FOILTEX® WHITE-TEX KING** (100gr/sqm)

**1 BOX = 400 CLOTHS**  
**CLOTH SIZE: 400MM X 310MM**



**CODE 27.22383** **FOILTEX® PERFECTING**  
SPECIFIC WASHCLOTH FOR MANUAL CLEANING OF  
SURFACES WITH ANTI-MARKING TREATMENT

**1 BOX = 250 CLOTHS**  
**CLOTH SIZE: 400MM X 310MM**



**CODE 27.22385**  
**SUPERTEX MINI-ROLLS**  
FOR MANUAL CLEANING

**N. 650 TEAR-OFF CLOTHS**  
**CLOTH SIZE: 400MM X 280MM**

**CODE 27.20926**

**PERFECTING WASH - SPEED FILM WASH**

(SCHWEGO DAMP 8174)  
SPECIAL CLEANER FOR  
ANTI-MARKING MATERIALS

**1 BOX = 12 BOTTLES OF 1 LT. EACH**



**CODE 27.22388**  
**SUPERTEX MINI-ROLLS**  
FOR MANUAL CLEANING

**NO TEAR-OFFS ON ROLL**  
**ROLL SIZE: 230-260MM X 500MT**  
(The roll width may vary from 230-260mm  
depending on availability)

# folex<sup>®</sup>

# PACK FOIL



FILM POLIESTERE DA UTILIZZARE NEI CILINDRI PORTA LASTRE E PORTA CAUCCIÙ PER IL RAGGIUNGIMENTO OTTIMALE DEL "PACK" NELLE MACCHINE DA SPAMPA.



POLYESTER FOIL FOR PLATE AND BLANKET CYLINDERS TO OBTAIN OPTIMUM "PACK" ON THE PRINTING PRESS.



FILM DE POLIESTER PARA UTILIZAR EN LOS CILINDROS PORTAPLANCHA Y PORTACAUCHOS, PARA CONSEGUIR UNA OPTIMA MANTILLA "PACK" EN LA MAQUINA DE IMPRIMIR.

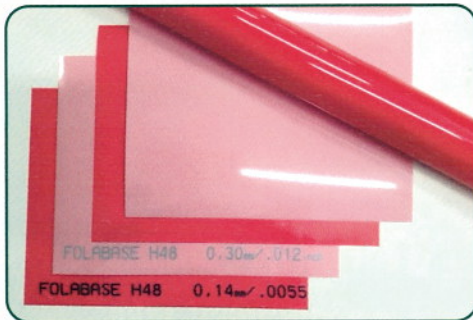

SPessori  
THICKNESSES  
ESPEsoRES

**PACK-FOIL ADESIVO - PACK-FOIL ADHESIVE - PACK-FOIL ADHESIVO (FOLEX H 48)**

mm 0,08 - 0,10 - 0,12 - 0,14 - 0,16 - 0,18 - 0,20 - 0,21 - 0,22 - 0,23 - 0,24 - 0,25 - 0,26 - 0,28 - 0,30 - 0,32 - 0,35 - 0,40 - 0,45 - 0,50

**PACK-FOIL NON ADESIVO - PACK-FOIL NON-ADHESIVE - PACK-FOIL NO ADHESIVO (FOLABASE "U")**

mm 0,10 - 0,12 - 0,14 - 0,16 - 0,18 - 0,20 - 0,23 - 0,25 - 0,28 - 0,30 - 0,35

**PACK-FOIL PUÒ ESSERE FORNITO IN ROTOLO O IN QUALSIASI FORMATO RICHIESTO  
PACK-FOIL CAN BE SUPPLIED IN ROLLS OR IN ANY SIZE OF CUT SHEETS YOU WISH TO REQUEST  
BAJO PEDIDO PODEMOS SUMINISTRAR EL PACK-FOIL EN ROLLOS O CORTADO EN CUALQUIER FORMATO**



# PERFECT BLADES®

RACLE DI LAVAGGIO PER RULLI INCHIOSTRATORI  
WASH-UP BLADES FOR INK ROLLERS  
REGLETAS DE LAVADO PARA RODILLOS ENTINTADORES

**MR** = metal and rubber

**MRE** = metal and rubber "EPDM"

**P** = plastic

**R** = rubber

**V** = vulcollan for "UV INKS"   
top quality rubber for traditional inks

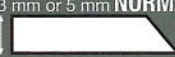
**T** = teflon for "UV INKS" 

**ST** = shaped teflon for "UV INKS"



**PVC**

**SP** = special plastic

**FA** = laminated fibre and aluminium

**RA** = rubber and aluminium

**MRA** = metal and rubber coupled

**F** = laminated fibre

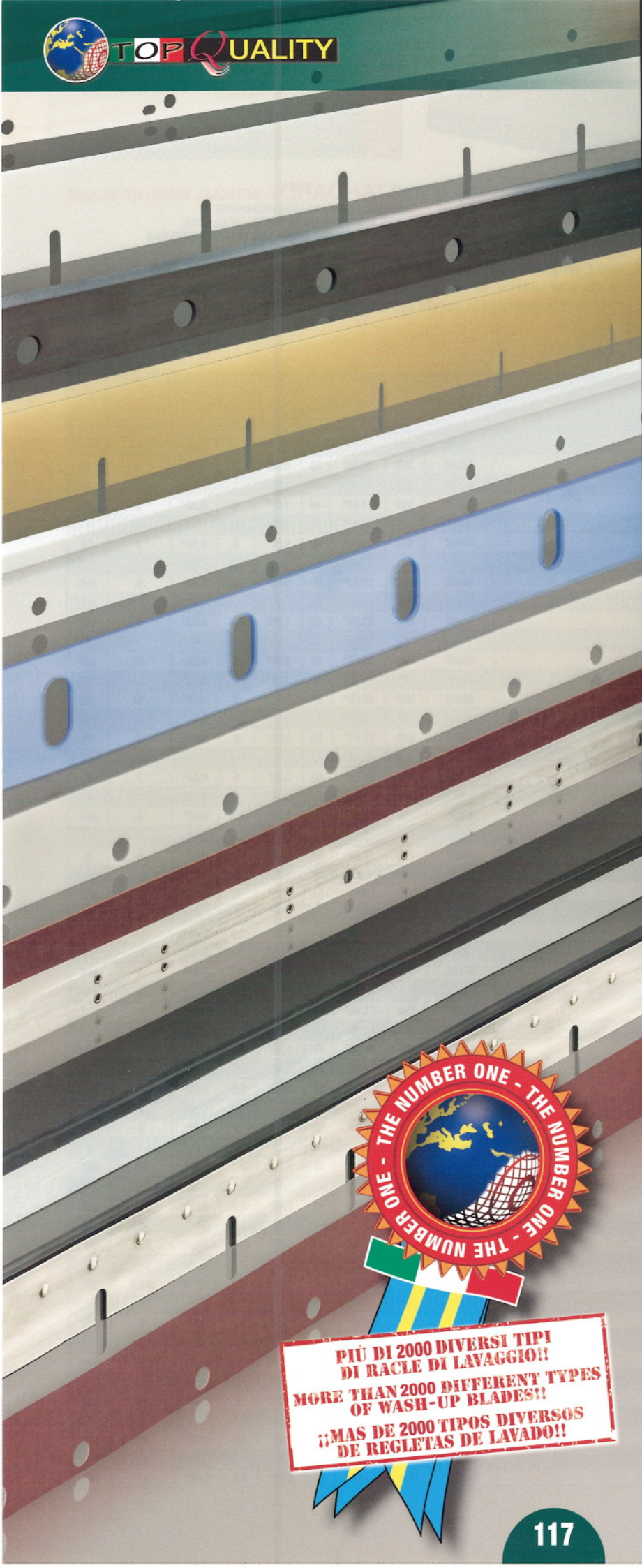



**PIÙ DI 2000 DIVERSI TIPI  
DI RACLE DI LAVAGGIO!!  
MORE THAN 2000 DIFFERENT TYPES  
OF WASH-UP BLADES!!  
¡¡MAS DE 2000 TIPOS DIVERSOS  
DE REGLETAS DE LAVADO!!**

	CHIAVE DI LETTURA
MR	MR = Metallo + Gomma
MRE	MRE = Metallo + Gomma EPDM
P	P = Plastica
SP	SP = Plastica speciale
R	R = Gomma
V	V = Vulcollan
T	T = Teflon
ST	ST = Teflon sagomato
PVC	PVC
FA	FA = Fibra laminata + Alluminio
RA	RA = Gomma + Alluminio
MRA	MRA = Metallo + Gomma accoppiata
F	F = Fibra laminata

	KEY
MR	MR = Metal + Rubber
MRE	MRE = Metal + Rubber "EPDM"
P	P = Plastic
SP	SP = Special plastic
R	R = Rubber
V	V = Vulcollan
T	T = Teflon
ST	ST = Shaped teflon
PVC	PVC
FA	FA = Laminated fibre + Aluminium
RA	RA = Rubber + Aluminium
MRA	MRA = Metal + Rubber coupled
F	F = Laminated fibre

	LLAVE DE LECTURA
MR	MR = Metal + Goma
MRE	MRE = METAL + Goma "EPDM"
P	P = Plastico
SP	SP = Plastico especial
R	R = Goma
V	V = Vulcollan
T	T = Teflon
ST	ST = Teflon moldeado
PVC	PVC
FA	FA = Fibra laminada + Aluminio
RA	RA = Goma + Aluminio
MRA	MRA = Metal + Goma acopiados
F	F = Fibra laminada



CODICE CODE CODIGO	MACCHINA E MODELLO - MACHINE & MODEL - MÁQUINA Y MODELO	FORMATO SIZE FORMATO	A		B		C		D	E
			MM	INCHES	MM	INCHES	MM	INCHES		
250	SPEEDMASTER 102 (STANDARD)	72x102	1090	42.91"	60	2.36"	0,5	0.02"	11	MR
251	SPEEDMASTER 102 (For "UV" inks) VULCOLLAN	72x102	1090	42.91"	60	2.36"	5	0.20"	11	V
270	SPEEDMASTER 102 (For "UV" inks) "HERCULES BLADE" 	72x102	1090	42.91"	60	2.36"	5/3	0.20"/0.12"	11	ST
265	SPEEDMASTER 102 CD (STANDARD) (Slots)	72x102	1090	42.91"	57	2.24"	0,5	0.02"	11	MR
265A	SPEEDMASTER 102 CD (STANDARD) PLASTIC	72x102	1090	42.91"	57	2.24"	1	0.04"	11	P
266	SPEEDMASTER 102 CD (For "UV" inks) VULCOLLAN	72x102	1090	42.91"	57	2.24"	5	0.20"	11	V
266A	SPEEDMASTER 102 CD (For "UV" inks) "HERCULES BLADE" 	72x102	1090	42.91"	57	2.24"	5/3	0.20"/0.12"	11	ST
268	SPEEDMASTER 105 XL - 106 XL (STANDARD)	75x105	1125	44.29"	41	1.61"	0,5	0.02"	15+6	MR
269	SPEEDMASTER 105 XL - 106 XL (For "UV" inks) VULCOLLAN	75x105	1125	44.29"	41	1.61"	5	0.20"	15+6	V
271	SPEEDMASTER 105 XL - 106 XL (SPECIAL) 		1130	44.49"	38,5	1.52"			0	RA
272	SPEEDMASTER 145 XL (STANDARD)		1707/1537	67.2"/60.51"	52	2.05"	0,5	0.02"	18	MR
273	SPEEDMASTER 145 XL VULCOLLAN		1707/1537	67.2"/60.51"	52	2.05"	5	0.20"	18	V
274	SPEEDMASTER 162 XL (STANDARD)		1707	67.20"	52	2.05"	0,5	0.02"	18	MR
276	SPEEDMASTER 162 XL VULCOLLAN		1707	67.20"	52	2.05"	5	0.20"	18	V

## HEIDELBERG ROTATIVE - WEB PRESSES - ROTATIVAS

CODICE CODE CODIGO	MACCHINA E MODELLO - MACHINE & MODEL - MÁQUINA Y MODELO	FORMATO SIZE FORMATO	A		B		C		D	E
			MM	INCHES	MM	INCHES	MM	INCHES		
275	WEB-8 HEIDELBERG/HARRIS WEB OFFSET 8 PG.		570	22.44"	51	2.01"	2	0.08"	8	MR
287	WEB-8 COOLING SYSTEM		600	23.62"	60	2.36"	0,5	0.02"	6	MR
280	WEB-MC 10 HEIDELBERG HARRIS WEB OFFSET		760	29.92"	70	2.76"	0,5	0.02"	8	MR
285	WEB-16 HEIDELBERG/HARRIS M600 WEB OFFSET 16 PG		1036	40.79"	51	2.01"	2	0.08"	12	MR
289	HEIDELBERG-M 4000 - WEB - HARRIS SUNDAY 64 PAG.		2035	80.12"	60	2.36"	0,5	0.02"	22	MR

## HEIDELBERG TIPOGRAFICHE

### TYPOGRAPHIC PRESSES - PLANOCILINDRICAS TIPOGRAFICAS

CODICE CODE CODIGO	MACCHINA E MODELLO - MACHINE & MODEL - MÁQUINA Y MODELO	FORMATO SIZE FORMATO	A		B		C		D	E
			MM	INCHES	MM	INCHES	MM	INCHES		
300	PLATINA PICCOLA Platen "T" - 10x15/Windmill	26x38	380	14.96"	51	2.01"	6	0.24"	5	MRA
305	PLATINA GRANDE Platen "GT" - 13X18/Windmill	32x46	470	18.50"	51	2.01"	6	0.24"	6	MRA
310	KS Pianocilindrica	38x52	530	20.87"	45	1.77"	1	0.04"	8	F
315	KSB-KSBA (ALL MODELS)	46x57	571	22.48"	45	1.77"	1	0.04"	8	F
320	OHZ Pianocilindrica	54x72	720	28.35"	46	1.81"	1	0.04"	10	F
325	SB-SBG Pianocilindrica	56x77	770	30.31"	46	1.81"	1	0.04"	10	F
335	SBB Pianocilindrica	57x82	811	31.93"	45	1.77"	1	0.04"	10	F
330	SBG II° Gruppo	56x77	833	32.80"	50	1.97"	1	0.04"	8	F
340	SBD Pianocilindrica	64x90	883	34.76"	45	1.77"	1	0.04"	10	F
345	SBD	64x90	890	35.00"	50	1.96"	0,5	0.02"	10	MR



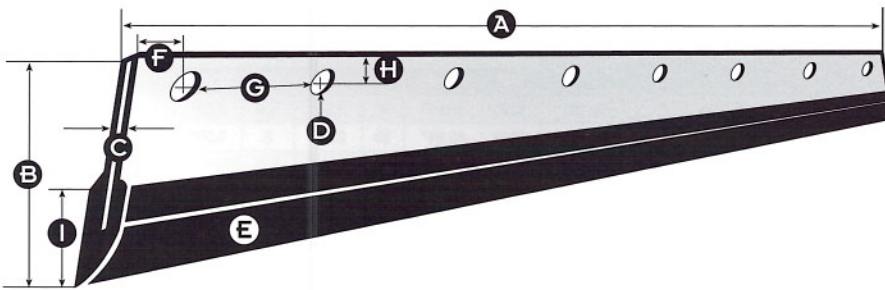

	CHIAVE DI LETTURA	KEY	LLAVE DE LECTURA
<b>A</b>	Lunghezza	Length	Longitud
<b>B</b>	Larghezza	Width	Ancho
<b>C</b>	Spessore	Thickness	Espesor
<b>D</b>	N° di fori	N° of holes	N° de agujeros
<b>E</b>	Materiale	Material	Material

**STANDARD = OFFICIAL WASH UP BLADE**  
 RACLE LAVARULLI PIÙ RICHIESTE  
 THE MOST POPULAR WASH-UP BLADES  
 REGLETAS LAVA-RODILLOS MAS SOLICITADAS

PER RACLE DI LAVAGGIO REALIZZATE IN MRE (PER INCHIOSTRI UV), VERRA' APPLICATO UN AUMENTO DI PREZZO DEL 15% SUL PREZZO DELLA RACLE REALIZZATA IN MR.  
 FOR WASH-UP BLADES MADE IN MRE (FOR UV INKS), WE WILL APPLY A 15% PRICE INCREASE ON THE PRICE OF THE BLADE IN MR.  
 PARA REGLETAS DE LAVADO REALIZADAS EN MRE (PARA TINTAS UV), SE APLICARA UN AUMENTO EN EL PRECIO DEL 15% SOBRE EL PRECIO DE LA REGLETA REALIZADA EN MR.

## HEIDELBERG GOSS

CODICE CODE CODIGO	MACCHINA E MODELLO - MACHINE & MODEL - MÁQUINA Y MODELO	FORMATO SIZE FORMATO	A		B		C		D	E
			MM	INCHES	MM	INCHES	MM	INCHES		
349	HEIDELBERG GOSS		993	39.09"	51	2.0"	0,5	0.02"	0	MR
351	HEIDELBERG GOSS		1098	43.23"	51	2.01"	0,5	0.02"	0	MR
350	HEIDELBERG GOSS UNILINER		1768	69.61"	63	2.48"	0,5	0.02"	14 + 5	MR

## HARRIS ROTATIVE - WEB OFFSET

CODICE CODE CODIGO	MACCHINA E MODELLO - MACHINE & MODEL - MÁQUINA Y MODELO	FORMATO SIZE FORMATO	A		B		C		D	E
			MM	INCHES	MM	INCHES	MM	INCHES		
1428	HARRIS VS 1250	WEB OFFSET	549	21.61"	28,5	1.12"	0,5	0.02"	0	MR
1430	HARRIS 24 ROTO OFFSET 990	WEB OFFSET	552	21.73"	53	2.09"	0,5	0.02"	6	MR
1435	HARRIS 1200	WEB OFFSET	590	23.23"	58	2.28"	0,5	0.02"	7	MR
1437	HARRIS 1220	WEB OFFSET	603	23.74"	51	2.00"	0,5	0.02"	7	MR
1440	HARRIS M 110	WEB OFFSET	749	29.49"	68	2.68"	0,5	0.02"	8	MR
1445	HARRIS	WEB OFFSET	997	39.25"	65	2.56"	0,5	0.02"	11	MR
1446	HARRIS M 1000 PLASTIC	WEB OFFSET	998	39.29"	90	3.54"	1	0.04"	7	P
1495	HARRIS MERCURY	WEB OFFSET	1036	40.79"	52	2.05"	0,5	0.02"	9	MR
1496	HARRIS	WEB OFFSET	1036	40.79"	50	1.97"	2	0.08"	12	MR
1460	HARRIS 1000 (Front/Tiro) M 200 - M 300	WEB OFFSET	1043	41.06"	65	2.56"	0,5	0.02"	11	MR
1465	HARRIS 1000 (Back/Retiro)	WEB OFFSET	1043	41.06"	103	4.06"	0,5	0.02"	11	MR
1475	HARRIS M 300 (Superiore e inferiore/Upper and lower)	WEB OFFSET	1043	41.06"	65	2.56"	0,5	0.02"	11	MR
1477	HARRIS/HEIDELBERG - 850	WEB OFFSET	1044	41.10"	84	3.31"	0,5	0.02"	11	MR
1447	HARRIS M 1000	WEB OFFSET	1054	41.50"	50	1.97"	0,5	0.02"	11	MR
1470	HARRIS M 1000	WEB OFFSET	1062	41.81"	98	3.86"	0,5	0.02"	11	MR
1480	HARRIS M 850	WEB OFFSET	1064	41.89"	38	1.50"	0,5	0.02"	11	MR
1485	HARRIS M 850	WEB OFFSET	1064	41.89"	60	2.36"	0,5	0.02"	11	MR
1490	HARRIS M 850	WEB OFFSET	1064	41.89"	88	3.46"	0,5	0.02"	11	MR
1450	HARRIS 200 (Front/Tiro)	WEB OFFSET	1065	41.93"	60	2.36"	0,5	0.02"	11	MR
1455	HARRIS 200 (Back/Retiro)	WEB OFFSET	1065	41.93"	78	3.07"	0,5	0.02"	11	MR
1494	HARRIS M 600	WEB OFFSET	1150	45.28"	60	2.36"	0,5	0.02"	10	MR
1497	HARRIS 946	WEB OFFSET	1225	48.23"	90	3.54"	0,5	0.02"	13	MR
1493	HARRIS N-900	WEB OFFSET	1226	48.26"	63.5	2.50"	0,5	0.02"	13	MR
1498	HARRIS HEIDELBERG	WEB OFFSET	1348	53.07"	90	3.54"	0,5	0.02"	14	MR
1499	HARRIS M 5000	WEB OFFSET	1353	53.27"	90	3.54"	0,5	0.02"	15	MR
1501	HARRIS	WEB OFFSET	1464	57.64"	50	1.97"	0,5	0.02"	13	MR
1518	HARRIS M 300	WEB OFFSET	1466	57.72"	50	1.97"	0,5	0.02"	13	MR
1501A	HARRIS SUNDAY 96	WEB OFFSET	1495	58.86"	60	2.36"	0,5	0.02"	32	MR
1501B	HARRIS SUNDAY GOSS 48	WEB OFFSET	1520	59.84"	60	2.36"	0,5	0.02"	16	MR
1505	HARRIS M 850 L (Macinazione superiore/Upper grinding/Cuerpo superior)	WEB OFFSET	1540	60.63"	64	2.52"	0,5	0.02"	17	MR
1500	HARRIS M 850 L	WEB OFFSET	1540	60.63"	78	3.07"	0,5	0.02"	17	MR
1510	HARRIS M 850 L (Macinazione inferiore/Lower grinding/Cuerpo inferior)	WEB OFFSET	1540	60.63"	88	3.46"	0,5	0.02"	17	MR
1512	HARRIS SUNDAY	WEB OFFSET	1580	62.20"	60	2.36"	0,5	0.02"	17	MR
1511	HARRIS ULTRAMAN	WEB OFFSET	1593	62.72"	65	2.56"	0,5	0.02"	17	MR
1517	HARRIS N 1700	WEB OFFSET	1665	65.55"	90	3.54"	0,5	0.02"	18	MR
1516	HARRIS N 1700	WEB OFFSET	1722	67.80"	64	2.52"	0,5	0.02"	18	MR
1513	HARRIS SUNDAY	WEB OFFSET	1750	68.90"	60	2.36"	0,5	0.02"	19	MR
1514	HARRIS SUNDAY	WEB OFFSET	1755	69.09"	75	2.95"	0,5	0.02"	19	MR
1515	HARRIS 1650	WEB OFFSET	1815	71.46"	98	3.86"	0,5	0.02"	19	MR
1519	HARRIS SUNDAY M 4000 (64Page/64 Pages/64 paginas)	WEB OFFSET	2035	80.12"	60	2.36"	0,5	0.02"	22	MR

## REALIZZAZIONE RACLE SPECIALI O PERSONALIZZATE

Qualsiasi racla non elencata nel presente listino potrà essere prodotta dietro esplicita richiesta ed indicazione per quantitativi minimi da convenire. Dovrà essere compilato con le relative quote il sottoindicato prospetto

## MANUFACTURE OF SPECIAL OR PERSONALISED WASH-UP BLADES

Any blade non included in this catalogue can be made on specific request; the minimum order requirement is to be agreed. Please complete the form below with all the details

## FABRICACION REGLITAS ESPECIALES O PERSONALIZADAS

Cualquier regleta que no figure en la presente lista podrá ser fabricada bajo pedido especial, acordando la cantidad mínima. Se deberán cumplimentar todas las medidas solicitadas en la plantilla abajo indicada

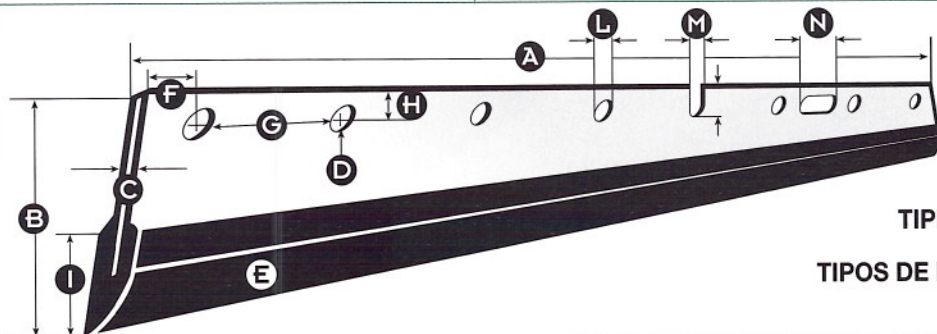

TIPI DI FORATURA  
HOLE TYPES  
TIPOS DE PERFORACION

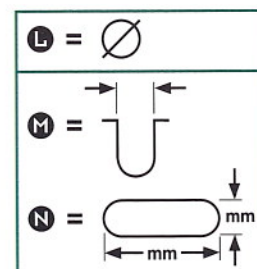

NOME DELLA MACCHINA E MODELLO		MACHINE NAME AND MODEL		NOMBRE DE LA MAQUINA Y MODELO		
N.B.: Per la buona riuscita dell'articolo si prega la gentile clientela di indicare esattamente le misure richieste in mm.		N.B.: Please indicate the exact measurements in mm./inches to ensure the perfect reproduction of the blade		N.B.: Para una perfecta producción del artículo, se ruega a la gentil clientela de indicar exactamente las medidas solicitadas en mm.		
LEGENDA	mm	KEY	mm	inch.	LLAVE DE LECTURA	mm
A = Lunghezza racla		A = Length of blade			A = Longitud regleta	
B = Larghezza complessiva		B = Overall width			B = Ancho total	
C = Spessore		C = Thickness			C = Grosor	
D = Numero fori		D = No. of holes			D = Numero de agujeros	
E = Tipo di racla		E = Blade type			E = Tipo de cuchilla	
MR = Metallo + gomma	<input type="checkbox"/>	MR = Metal + rubber	<input type="checkbox"/>		MR = Metal + goma	<input type="checkbox"/>
R = Gomma	<input type="checkbox"/>	R = Rubber	<input type="checkbox"/>		R = Goma	<input type="checkbox"/>
P = Plastica speciale	<input type="checkbox"/>	P = Special plastic	<input type="checkbox"/>		P = Plástico especial	<input type="checkbox"/>
T = Teflon	<input type="checkbox"/>	T = Teflon	<input type="checkbox"/>		T = Teflón	<input type="checkbox"/>
V = Vulcollan	<input type="checkbox"/>	V = Vulcollan	<input type="checkbox"/>		V = Vulcollan	<input type="checkbox"/>
F = Fibra laminata	<input type="checkbox"/>	F = Laminated fibre	<input type="checkbox"/>		F = Fibra laminada	<input type="checkbox"/>
F = Distanza dallo spigolo al centro del primo foro		F = Distance from blade end to centre of first hole			F = Distancia del extremo al centro del primer agujero	
G = Distanza dei fori (da centro a centro)		G = Hole spacing (centre to centre)			G = Distancia entre los agujeros (del centro al centro)	
H = Distanza dal lato della racla al centro del foro		H = Distance from blade edge to centre of hole			H = Distancia del borde al centro del agujero	
I = Altezza profilo in gomma		I = Rubber profile width			I = Ancho del perfil de goma	
L = Diametro foro		L = Diametre of hole			L = Diametro del agujero	
M = Dimensioni asola		M = Sizes of slot			M = Dimensiones del las muescas	
N = Dimensioni foro ovale		N = Sizes of oval hole			N = Dimensiones del agujero ovalado	
"STANDARD" = Profilo in gomma "NBR" con durezza "STANDARD" a 95 shore (dura)	<input type="checkbox"/>	"STANDARD" = Rubber profile "NBR" with 95 "STANDARD" shore (hard)	<input type="checkbox"/>		"ESTANDAR" = Perfil de goma "NBR" con durezza "ESTANDAR" 95 shore (dura)	<input type="checkbox"/>
"SOFT" = Profilo in gomma "NBR" con durezza "SPECIALE" a 85 shore (morbida)	<input type="checkbox"/>	"SOFT" = Rubber profile "NBR" with 85 "SPECIAL" shore (soft)	<input type="checkbox"/>		"SOFT" = Perfil de goma "NBR" con durezza "ESPECIAL" 85 shore (blanda)	<input type="checkbox"/>
"UV" = Profilo in gomma "EPDM" con durezza 95 hole in presenza di macchine stampa che utilizzano inchiostri "UV"	<input type="checkbox"/>	"UV" = Rubber profile "EPDM" with 95 shore for "UV" ink printing machines	<input type="checkbox"/>		"UV" = Perfil de goma "EPDM" con durezza 95 shore para maquinas que usan tintas "UV"	<input type="checkbox"/>
<b>IMPORTANTE:</b> Su specifica richiesta tutte le racla lavarulli da noi prodotte possono essere fornite con lo speciale profilo in gomma "EPDM" avente durezza 85 shore necessario nei casi si presentino macchine da stampa che utilizzano inchiostri "UV"		<b>IMPORTANT:</b> On specific request, all the blades we manufacture can be supplied with special "EDPM" rubber profile with 85 shore, required for "UV" ink printing		<b>IMPORTANTE:</b> Bajo pedido especial, todas las regletas fabricadas por nosotros se pueden suministrar con el perfil en goma "EPDM" con durezza 85 shore, necesario para todas las máquinas que trabajan con tintas "UV"		



**HEIDELBERG**



# SUPER COAT SEALS®

GUARNIZIONI LATERALI PER IMPIANTI DI VERNICIATURA  
LATERAL COAT SEALS FOR COATING UNITS  
GUARNICIONES LATERALES PARA INSTALACIONES DE BARNIZADO

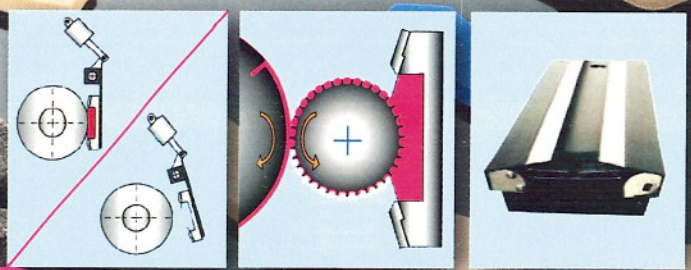

# SUPER COAT SEALS FOR HEIDELBERG FOR TRESU CHAMBERS FOR WATER-BASED AND UV COATING

MODEL	SM52 - SM72 - SM74 - 74CD - 75XL - SM102 - 102CD - 102CX 105XL - 106XL
-------	--

## UNIVERSAL COAT SEAL FOR TRESU D2

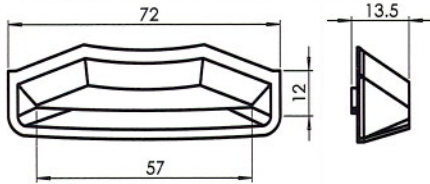

confezione da 50 pz / packet of 50 pcs / confeccion de 50 pz



CODE 18650: EPDM RUBBER



CODE 18650A: IMPREGNATED FELT

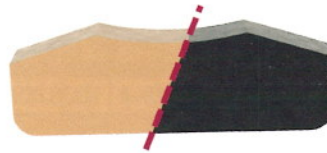

CODE 18650B: FOAM BEIGE  
CODE 18650D: FOAM BLACK



CODE 18650C: SILICONE

MODEL	145XL - 162XL
-------	---------------

## FOR TRESU D4

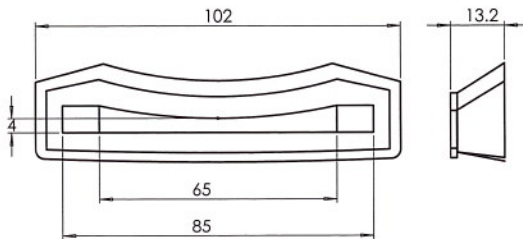

confezione da 50 pz / packet of 50 pcs / confeccion de 50 pz



CODE 18653: EPDM RUBBER



CODE 18653A: IMPREGNATED FELT



CODE 18653B: FOAM BEIGE  
CODE 18653C: FOAM BLACK

## SUPER COAT SEALS FOR GALLUS

Richiedete ulteriori informazioni per e-mail  
Request more information by e-mail  
Solicite mayor información por correo

18651	BLOCKING CLIP MOLLA DI BLOCCAGGIO D1 - D2 - SMALL
-------	---

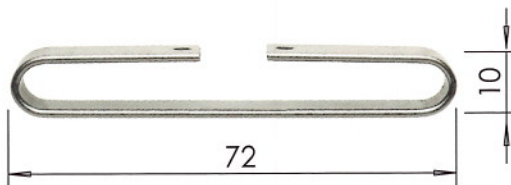

confezione da 12 pz / packet of 12 pcs / confeccion de 12 pz

18651A	BLOCKING CLIP MOLLA DI BLOCCAGGIO D3 - D4 - D5 - LARGE
--------	--

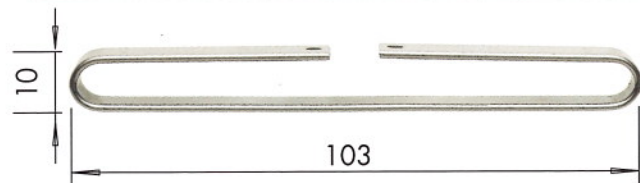

confezione da 12 pz / packet of 12 pcs / confeccion de 12 pz

CODE	DESCRIPTION
18684	PINCER FOR SUPER COAT SEAL



CODE	DESCRIPTION
18686	SUPER GEL LUBRICATION (tube of 250 ml)



# SUPER DOCTOR BLADES

IN ACCIAIO – IN STEEL – EN ACERO

PER VERNICI ACRILICHE A BASE DI ACQUA E VERNICI “UV”  
FOR ACRYLIC WATER BASED AND “UV” COATINGS  
PARA BARNICES ACRILICOS BASE AGUA Y BARNICES “UV”

UNIVERSAL  
PRODUCT

IN ROTOLO – IN ROLLS – EN ROLLOS

CODICE CODE CODIGO	MODELLO MACCHINA MACHINE MODEL MODELO DE MAQUINA	ALTEZZA / SPESSORE IN MM WIDTH / THICKNESS IN MM ANCHO / ESPESOR IN MM	FORNITO IN ROTOLO SUPPLIED IN ROLLS SUMINISTRADO EN ROLLOS	GRUPPO DI VERNICIATURA VARNISHING GROUP GRUPO DE BARNIZADO
18504-A	HEIDELBERG	35MM X 0,20MM	ROLL OF 100 MT.	TRESU

IN LUNGHEZZE PRE-TAGLIATE - IN PRE-CUT LENGTHS - EN LONGITUD PRECORTADAS  
PER GRUPPO “TRESU” - FOR “TRESU” CHAMBERS - PARA GRUPO “TRESU”

CODICE CODE CODIGO	MODELLO MACCHINA MACHINE MODEL MODELO DE MAQUINA	ALTEZZA / SPESSORE IN MM WIDTH / THICKNESS IN MM ANCHO / ESPESOR IN MM	LUNGHEZZA IN MM LENGTH IN MM LONGITUD IN MM
18509	HEIDELBERG SPEEDMASTER 52 (ANICOLOR)	30MM X 0,15MM	560MM
18509B	HEIDELBERG SPEEDMASTER 74 (ANICOLOR)	30MM X 0,15MM	780MM
18510	HEIDELBERG SPEEDMASTER 52	35MM X 0,20MM	560MM
18511	HEIDELBERG SPEEDMASTER 72	35MM X 0,20MM	765MM
18512	HEIDELBERG SPEEDMASTER 74	35MM X 0,20MM	780MM
18513	HEIDELBERG SPEEDMASTER 74 CD	35MM X 0,20MM	786MM
18514	HEIDELBERG SPEEDMASTER 75 XL	35MM X 0,20MM	792MM
18515	HEIDELBERG SPEEDMASTER 102	35MM X 0,20MM	1060MM
18516	HEIDELBERG SPEEDMASTER 102 CD	35MM X 0,20MM	1065MM
18517	HEIDELBERG SPEEDMASTER 105 XL - 106 XL	35MM X 0,20MM	1110MM
18518	HEIDELBERG SPEEDMASTER 145 XL	35MM X 0,20MM	1515MM
18519	HEIDELBERG SPEEDMASTER 162 XL	35MM X 0,20MM	1680MM

# SUPER DOCTOR BLADES

IN PLASTICA – IN PLASTIC – EN PLASTICO

DISPONIBILI SU RICHIESTA - AVAILABLE ON REQUEST - DISPONIBLES POR PEDIDO

NEW



SECTION

CODICE CODE CODIGO	ALTEZZA / SPESSORE IN MM WIDTH / THICKNESS IN MM ANCHO / ESPESOR IN MM	LUNGHEZZA IN MT. LENGTH IN MT. LONGITUD IN MT.
18702C	35MM X 0,35MM	ROLL OF 100 MT.

# ROYAL CUTTER

FOR DOCTOR BLADES

The new Royal Cutter for Doctor Blades allows you to cut to any size in total freedom. Furthermore, to make it easier for you, we have created three versions with variable maximum extension.

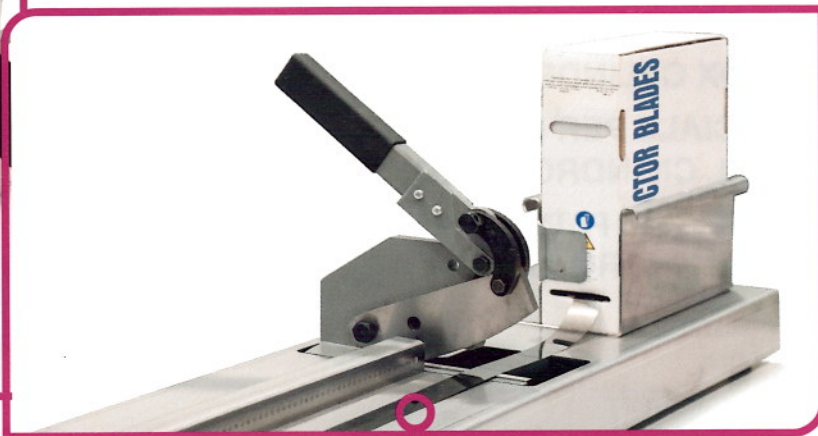

**NEW**

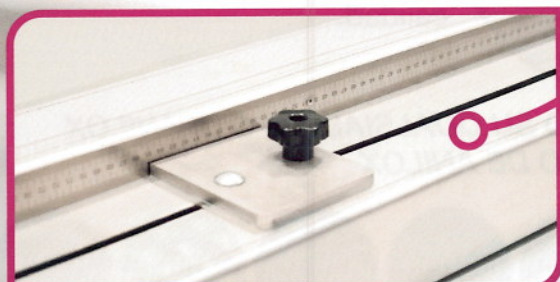

**THE WIDTH  
AND THE HEIGHT  
CAN BE REGULATED !!**

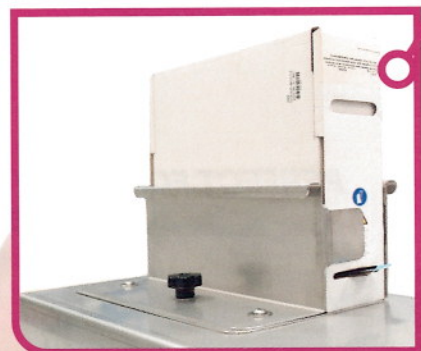

CODE	DESCRIPTION - SIZE
18740	ROYAL CUTTER SIZE 1300mm
18741	ROYAL CUTTER SIZE 1500mm
18742	ROYAL CUTTER SIZE 1700mm



# NEW SPECIAL ANILOX SPONGE®

CODE	DESCRIPTION
18645	SPECIAL ANILOX SPONGE

**SPECIAL SPONGE FOR OPTIMAL CLEANING OF THE ANILOX CYLINDER.**

**SPUGNA SPECIALE PER UNA PULIZIA OTTIMALE DEL CILINDRO ANILOX.**

**ESPONJA ESPECIAL PARA UNA LIMPIEZA ÓPTIMA DEL CILINDRO ANILOX.**

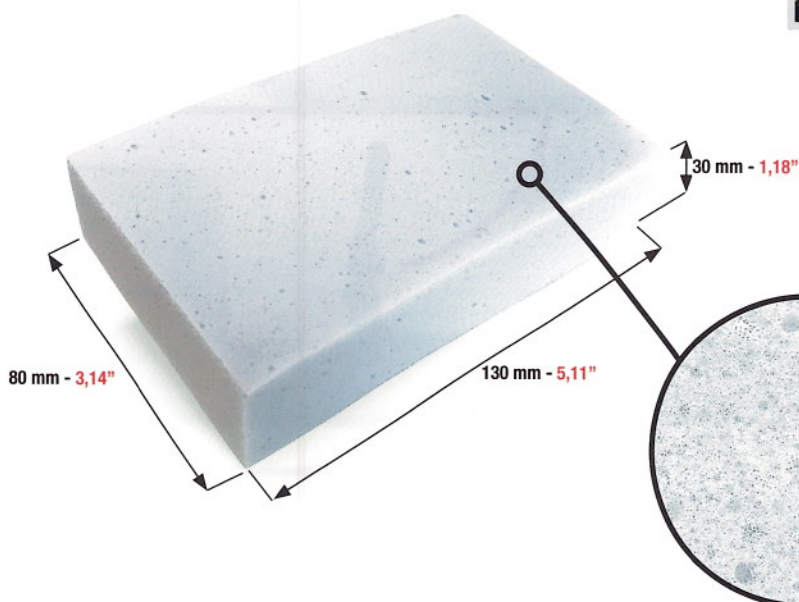

**MINIMUM ORDER  
50 PCS**

Special top quality material.  
Materiale speciale di altissima qualità.  
Material especial de primera calidad.

**PERFECT FOR EVERY ANILOX DESIGN - PERFETTO SU QUALSIASI TIPO DI ANILOX  
PERFECTO PARA CADA DISEÑO DE ANILOX**

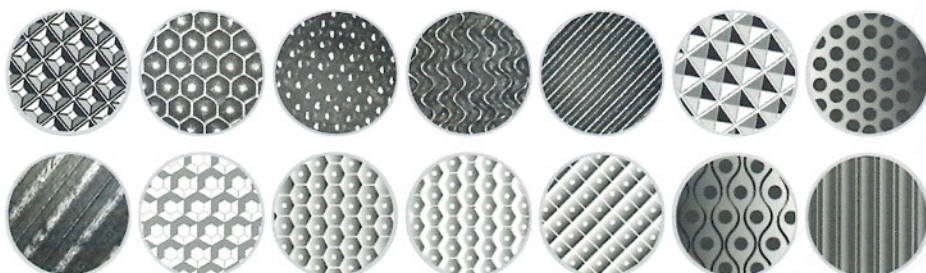
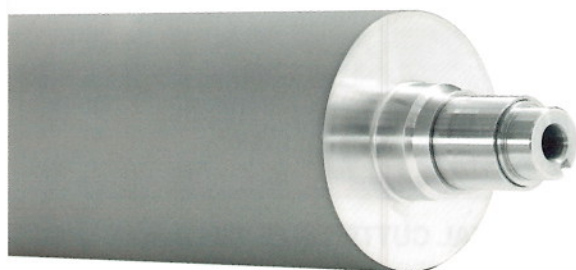

**REQUEST BY E-MAIL THE PRICE LIST RESERVED FOR YOU.  
RICHIEDETE PER E-MAIL IL LISTINO PREZZI A VOI RISERVATO.  
SOLICITE POR CORREO ELECTRONICO LA LISTA DE PRECIOS  
RESERVADA PARA USTED.**





# ROYAL TOP PLATE®

THE NUMBER ONE SINCE 1987



## HIGH QUALITY COATING PLATES

### SURFACE IN RESIN

- VERY EASY TO STRIP.
- 100% SPLITTING (COATING TRANSFER).
- NO INK BUILD-UP.
- SHARP AND CLEAN EDGES EVEN AFTER LONG PRINT RUNS.
- COMPATIBLE WITH ALL TYPES OF COATINGS: UV, WATER-BASED, GLOSSY, MATT, ETC..
- HIGH DIMENSIONAL STABILITY ALWAYS GUARANTEES A PERFECT REGISTER.
- AVAILABLE IN ANY SIZE.

#### SPECS:

COLOUR	Blue	Blue	Blue
BI-DIRECTIONAL	Yes	Yes	Yes
CARRIER	Polyester	Polyester	Polyester
NOMINAL THICKNESS MM Tolerance +/- 0,02mm	1,15mm	1,35mm	1,95mm
THICKNESS OF CARRIER	0,35mm	0,35mm	0,35mm
THICKNESS OF THERMOPLASTIC STRIPPING LAYER MM	0,80mm	1,00mm	1,60mm
COATING COMPATIBILITY	Water-based and UV	Water based and UV	Water based and UV
ROUGHNESS (Ra:µm)	0,8 - 1,2 µm	0,8 - 1,2 µm	0,8 - 1,2 µm
STRIPPING DEPTH MM	0,80mm	1,00mm	1,60mm
SURFACE HARDNESS (Shore A)	75°	75°	75°





# ROYAL COAT COATING PLATES WITH RUBBER SURFACE

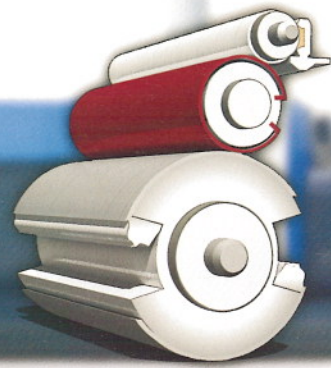

## ROYAL COAT

COLOUR	Blue	Blue	Blue
BI-DIRECTIONAL	Yes	Yes	Yes
CARRIER	Polyester	Polyester	Polyester
NOMINAL THICKNESS MM Tolerance +/- 0,02mm	1,15mm	1,35mm	1,95mm
THICKNESS OF CARRIER	0,35mm	0,35mm	0,35mm
COMPRESSIBLE layer	-	-	yes
THICKNESS OF COMPRESSIBLE LAYER MM	-	-	0,60
COATING COMPATIBILITY	aqueous + UV	aqueous + UV	aqueous + UV
ROUGHNESS (Ra:µm)	0,6 - 0,9 µm	0,6 - 0,9 µm	0,6 - 0,9 µm
STRIPPING DEPTH MM	0,80mm	1,00mm	1,00mm

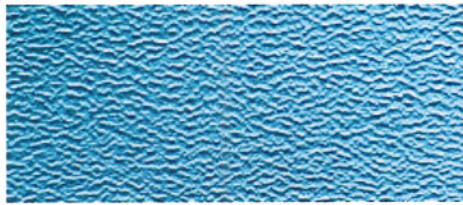

## ROYAL COAT PLUS

COLOUR	Grey	Grey	Grey
BI-DIRECTIONAL	Yes	Yes	Yes
CARRIER	Polyester	Polyester	Polyester
NOMINAL THICKNESS MM Tolerance +/- 0,02mm	1,15mm	1,35mm	1,95mm
THICKNESS OF CARRIER	0,35mm	0,35mm	0,35mm
COMPRESSIBLE layer	-	-	yes
THICKNESS OF COMPRESSIBLE LAYER MM	-	-	0,60
COATING COMPATIBILITY	aqueous + UV	aqueous + UV	aqueous + UV
ROUGHNESS (Ra:µm)	0,5 - 0,7 µm	0,5 - 0,7 µm	0,5 - 0,7 µm
STRIPPING DEPTH MM	0,80mm	1,00mm	1,00mm



## ROYAL COAT UV

COLOUR	Purple	Purple	Purple
BI-DIRECTIONAL	Yes	Yes	Yes
CARRIER	Polyester	Polyester	Polyester
NOMINAL THICKNESS MM Tolerance +/- 0,02mm	1,15mm	1,35mm	1,95mm
THICKNESS OF CARRIER	0,35mm	0,35mm	0,35mm
COMPRESSIBLE layer	-	-	yes
THICKNESS OF COMPRESSIBLE LAYER MM	-	-	0,60
COATING COMPATIBILITY	UV	UV	UV
ROUGHNESS (Ra:µm)	0,6 - 0,8 µm	0,6 - 0,8 µm	0,6 - 0,8 µm
STRIPPING DEPTH MM	0,80mm	1,00mm	1,00mm

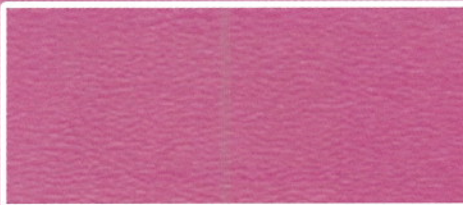

## ROYAL SUPERCOAT

COLOUR	Patina Green	Patina Green	Patina Green
BI-DIRECTIONAL	Yes	Yes	Yes
CARRIER	Polyester	Polyester	Polyester
NOMINAL THICKNESS MM Tolerance +/- 0,02mm	1,15mm	1,35mm	1,95mm
THICKNESS OF CARRIER	0,35mm	0,35mm	0,35mm
COMPRESSIBLE layer	Yes	Yes	Yes
COATING COMPATIBILITY	Aqueous + UV	Aqueous + UV	Aqueous + UV
ROUGHNESS (Ra:µm)	0,6 - 0,9 µm	0,6 - 0,9 µm	0,6 - 0,9 µm
STRIPPING DEPTH MM	0,80mm	1,00mm	1,60mm



## ROYAL STRIP BLANKET



COLOUR	BLUE
CONSTRUCTION	3 FABRIC LAYERS
COMPRESSIBLE LAYER	CLOSED CELLS
THICKNESS MM	1,95 ± 0,02 MM
HARDNESS ( TOTAL )	80° SHORE A
TENSILE STRENGTH	105 ( N/MM )
COMPRESSIBILITY	650 N/3 CM <sup>2</sup>
APPLICATION FIELDS	VARNISHING GROUP
IDENTIFICATION LINES	SINGLE LINE
INK COMPATIBILITY	70% ACRYLIC VARNISH, 30% UV VARNISH

ROYAL UNDER COAT

# ROYAL UNDER COAT®

UNDERPACKING SPECIFIC  
FOR COATING PLATES

\*MOST FREQUENTLY USED THICKNESS

## ROYAL UNDERCOAT NON ADHESIVE

- FABRIC
- FABRIC

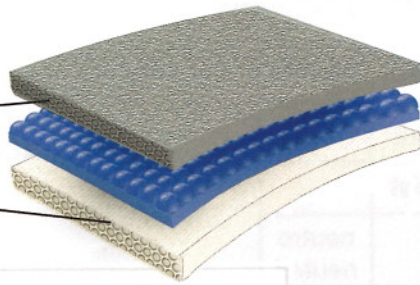

## ROYAL UNDERCOAT ADHESIVE

- FABRIC
- FABRIC
- ADHESIVE

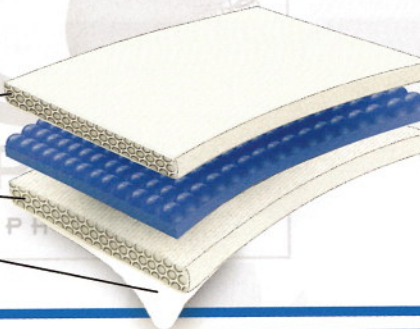

## ROYAL UNDERCOAT ADHESIVE + POLYESTER

- FABRIC
- POLYESTER
- FABRIC
- ADHESIVE

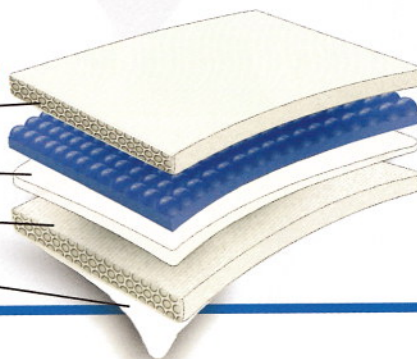

Thicknesses

mm.

0,65  
0,75  
0,85  
0,90  
0,95  
1,00  
1,05  
1,20  
1,30  
1,35  
1,40  
1,45  
1,50  
1,65  
1,70  
1,85  
1,95  
2,00  
2,05  
2,10\*  
2,15  
2,30

other thicknesses  
available on request

Surface: Fabric  
Tolerance +/- 0,01



FOGRA CERTIFICATION  
IN PREPARATION



# SUPER COAT®

**SPECIALE RIVESTIMENTO PLASTICO AUTOADESIVO PER VERNICIATURA INDIRETTA CON RISERVE**  
**SPECIAL SELF-ADHESIVE PLASTIC MATERIAL FOR OFF-LINE SPOT COATING**  
**REVESTIMIENTO PLASTICO ESPECIAL AUTOADHESIVO PARA BARNIZADO INDIRECTO CON RESERVA**

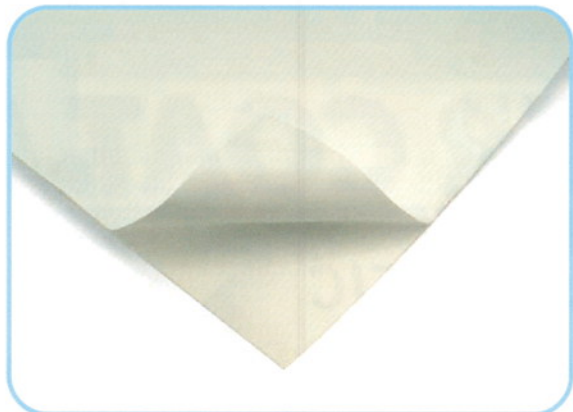

## SUPER COAT "PLUS"

SPESSORE THICKNESS ESPESOR		SEMITRASPARENTE SEMITRASPARENT SEMITRASPARENTE		COLORE COLOUR COLOR
mm	inch.		adesivi	
0,53	0,021	x	x	neutro neutral

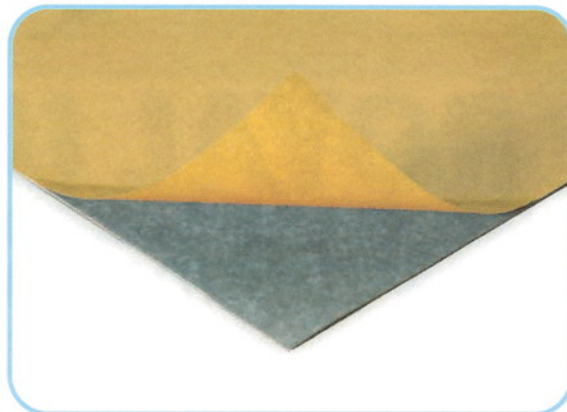

## SUPER COAT "GREY"

SPESSORE THICKNESS ESPESOR		SEMITRASPARENTE SEMITRASPARENT SEMITRASPARENTE		COLORE COLOUR COLOR
mm	inch.		adesivi	
0,70	0,028	-	x	grigio grey/gris

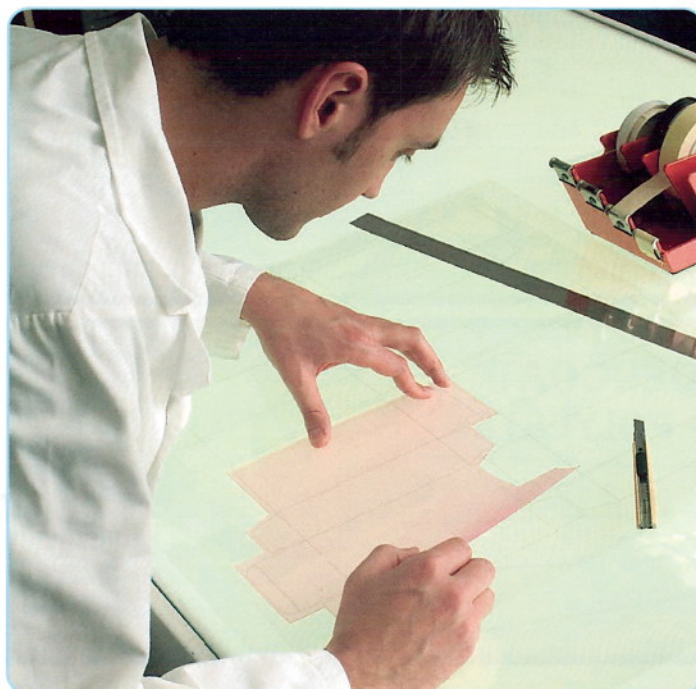

**SUPER COAT PUÒ ESSERE FORNITO IN ROTOLO O IN QUALSIASI FORMATO RICHIESTO**  
**SUPER COAT CAN BE SUPPLIED IN ROLLS OR IN ANY SIZE OF CUT SHEETS YOU WISH TO REQUEST**  
**BAJO PEDIDO PODEMOS SUMINISTRAR EL SUPER COAT EN ROLLOS O CORTADO EN CUALQUIER FORMATO**



**CINGHIE DI RALLENTAMENTO FOGLI  
SHEET SLOWDOWN BELTS  
CORREAS PARA REDUCIR LA MARCHA DE LA HOJA**

**GIALLA  
YELLOW  
AMARILLA**

9 mm - 0,35"



**34**  
FORI / HOLES  
AGUJEROS

229 mm x 20 mm  
9,02" x 0,79"

CINGHIA DI RALLENTAMENTO FOGLI RIALZATA PER:  
RAISED SHEET SLOWDOWN BELT FOR:  
CORREA REALZADA PARA REDUCIR LA MARCHA DE LA HOJA PARA:

**SPEEDMASTER 52/74/74CD/102/102CD/105XL/106XL**

COMPATIBLE WITH OEM CODE

CODICE - CODE - CÓDIGO

**M2.015.840F**

**6027**

**VERDE  
GREEN**



**34**  
FORI / HOLES  
AGUJEROS

235 mm x 20 mm  
9,25" x 0,79"

CINGHIA DI RALLENTAMENTO FOGLI PIATTA PER:  
FLAT SHEET SLOWDOWN BELT FOR:  
CORREA PLANA PARA REDUCIR LA MARCHA DE LA HOJA PARA:

**SPEEDMASTER 75XL/102/102CD/102CX/105XL/  
106XL/145XL/162XL**

COMPATIBLE WITH OEM CODE

CODICE - CODE - CÓDIGO

**M2.015.880**

**6028**

**GRIGIA  
GREY  
GRIS**

9 mm - 0,35"



**34**  
FORI / HOLES  
AGUJEROS

225 mm x 20 mm  
8,86" x 0,79"

CINGHIA DI RALLENTAMENTO FOGLI RIALZATA PER:  
RAISED SHEET SLOWDOWN BELT FOR:  
CORREA REALZADA PARA REDUCIR LA MARCHA DE LA HOJA PARA:

**SPEEDMASTER 52/74/74CD/75XL/  
102CD/105XL/106XL**

COMPATIBLE WITH OEM CODE

CODICE - CODE - CÓDIGO

**M2.015.843F**

**6029**

**GIALLA  
YELLOW  
AMARILLA**



**34**  
FORI / HOLES  
AGUJEROS

225 mm x 20 mm  
8,86" x 0,79"

CINGHIA DI RALLENTAMENTO FOGLI PIATTA PER:  
FLAT SHEET SLOWDOWN BELT FOR:  
CORREA PLANA PARA REDUCIR LA MARCHA DE LA HOJA PARA:

**SPEEDMASTER 52/74/74CD/102/102CD/  
105XL/106XL**

COMPATIBLE WITH OEM CODE

CODICE - CODE - CÓDIGO

**M2.015.878**

**6030**

**GRIGIA**  
**GREY**  
**GRIS**



**34**  
FORI / HOLES  
AGUJEROS

225 mm x 20 mm  
8,86" x 0,79"

CINGHIA DI RALLENTAMENTO FOGLI PIATTA PER:  
FLAT SHEET SLOWDOWN BELT FOR:  
CORREA PLANA PARA REDUCIR LA MARCHA DE LA HOJA PARA:

**SPEEDMASTER 52/74/74CD/75XL/102/  
105XL/106XL**

COMPATIBLE WITH OEM CODE

CODICE - CODE - CÓDIGO

**M2.015.881F**

**6031**

**ROSA**  
**PINK**



**30**  
FORI / HOLES  
AGUJEROS

220 mm x 38 mm  
8,66" x 1,50"

CINGHIA DI RALLENTAMENTO FOGLI RIALZATA PER:  
RAISED SHEET SLOWDOWN BELT FOR:  
CORREA REALZADA PARA REDUCIR LA MARCHA DE LA HOJA PARA:

**SPEEDMASTER 74**

COMPATIBLE WITH OEM CODE

CODICE - CODE - CÓDIGO

**M2.015.357/01**

**6032**

**GRIGIA**  
**GREY**  
**GRIS**



**34**  
FORI / HOLES  
AGUJEROS

247 mm x 20 mm  
9,72" x 0,79"

CINGHIA DI RALLENTAMENTO FOGLI PIATTA PER:  
FLAT SHEET SLOWDOWN BELT FOR:  
CORREA PLANA PARA REDUCIR LA MARCHA DE LA HOJA PARA:

**SPEEDMASTER 74/74CD/75XL/102/102CD/105XL/  
145XL/162XL**

COMPATIBLE WITH OEM CODE

CODICE - CODE - CÓDIGO

**F4.614.831F**

**6031-A**



**69**  
FORI / HOLES  
AGUJEROS

220 mm x 37 mm  
8,66" x 1,46"

CINGHIA DI RALLENTAMENTO FOGLI PER:  
SHEET SLOWDOWN BELT FOR:  
CORREA PARA REDUCIR LA MARCHA DE LA HOJA PARA:

**SPEEDMASTER 74/102/102CD**

COMPATIBLE WITH OEM CODE

CODICE - CODE - CÓDIGO

**C3.015.453**

**6022**

**GRIGIA**  
**GREY**  
**GRIS**



**34**  
FORI / HOLES  
AGUJEROS

225 mm x 20 mm  
8,86" x 0,79"

CINGHIA DI RALLENTAMENTO FOGLI RIALZATA PER:  
RAISED SHEET SLOWDOWN BELT FOR:  
CORREA REALZADA PARA REDUCIR LA MARCHA DE LA HOJA PARA:

**SPEEDMASTER 52/74/74CD/102/102CD/  
105XL/106XL**

COMPATIBLE WITH OEM CODE

CODICE - CODE - CÓDIGO

**M2.015.898F**

**6032-A**

**GRIGIA**  
**GREY**  
**GRIS**

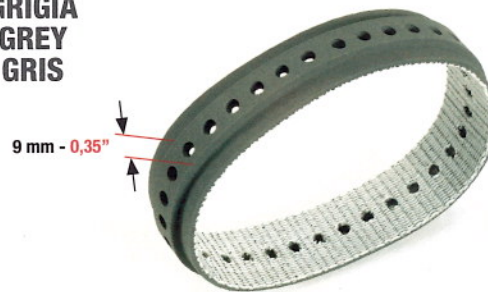

**34**  
FORI / HOLES  
AGUJEROS

247 mm x 20 mm  
9,72" x 0,79"

CINGHIA DI RALLENTAMENTO FOGLI RIALZATA PER:  
RAISED SHEET SLOWDOWN BELT FOR:  
CORREA REALZADA PARA REDUCIR LA MARCHA DE LA HOJA PARA:

**SPEEDMASTER 74CD/75XL/102/102CD/105XL/106XL/  
145XL/162XL**

COMPATIBLE WITH OEM CODE

CODICE - CODE - CÓDIGO

**F4.614.821/F**

**6032-B**

**GIALLA  
YELLOW  
AMARILLA**

5 mm - 0,20"

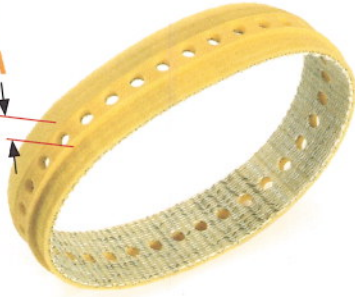

**34**  
FORI / HOLES  
AGUJEROS

229 mm x 20 mm  
9,02" x 0,79"

CINGHIA DI RALLENTAMENTO FOGLI RIALZATA PER:  
RAISED SHEET SLOWDOWN BELT FOR:  
CORREA REALZADA PARA REDUCIR LA MARCHA DE LA HOJA PARA:

**SPEEDMASTER 52/74/74CD/102/102CD/105XL/106XL**

COMPATIBLE WITH OEM CODE

CODICE - CODE - CÓDIGO

**M2.015.896F/01**

**6033**

**GRIGIA  
GREY  
GRIS**

1,5 mm - 0,06"



**34**  
FORI / HOLES  
AGUJEROS

225 mm x 20 mm  
8,86" x 0,79"

CINGHIA DI RALLENTAMENTO FOGLI RIALZATA PER:  
RAISED SHEET SLOWDOWN BELT FOR:  
CORREA REALZADA PARA REDUCIR LA MARCHA DE LA HOJA PARA:

**SPEEDMASTER 52/74/74CD/102/102CD/  
105XL/106XL**

COMPATIBLE WITH OEM CODE

CODICE - CODE - CÓDIGO

**M2.015.872/01**

**6034**

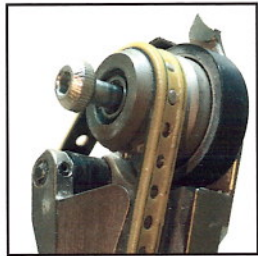

10 mm - 0,39"

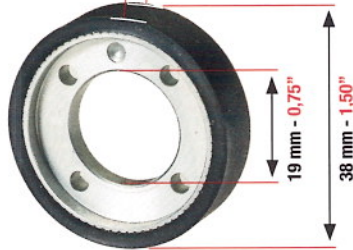

19 mm - 0,75"  
38 mm - 1,50"

RUOTA PER CINGHIA DI RALLENTAMENTO PER:  
WHEEL FOR SLOWDOWN BELT FOR:  
RUEDA PARA CORREA PARA REDUCIR LA MARCHA DE LA HOJA PARA:

**SPEEDMASTER 105XL/106XL/145XL/162XL**

COMPATIBLE WITH OEM CODE

CODICE - CODE - CÓDIGO

**F4.614.555**

**4659**

**BLU  
BLUE  
AZUL**



**34**  
FORI / HOLES  
AGUJEROS

245 mm x 10 mm  
9,65" x 0,39"

CINGHIA DI RALLENTAMENTO FOGLI PER:  
SHEET SLOWDOWN BELT FOR:  
CORREA PARA REDUCIR LA MARCHA DE LA HOJA PARA:

**SPEEDMASTER 75XL/102/105XL/106XL/145XL/162XL**

COMPATIBLE WITH OEM CODE

CODICE - CODE - CÓDIGO

**F4.614.560/01**

**6036 (RUBBER)**

**F4.614.560/01**

**6036PU (POLYURETHANE)  
ORIGINAL**

**BIANCO  
WHITE  
BLANCO**



**34**  
FORI / HOLES  
AGUJEROS

245 mm x 10 mm  
9,65" x 0,39"

CINGHIA DI RALLENTAMENTO FOGLI PER:  
SHEET SLOWDOWN BELT FOR:  
CORREA PARA REDUCIR LA MARCHA DE LA HOJA PARA:

**SPEEDMASTER 75XL/102/105XL/106XL/145XL/162XL**

COMPATIBLE WITH OEM CODE

CODICE - CODE - CÓDIGO

**F4.614.881F**

**6036-A**

**ROSSA  
RED  
ROJA**



**34**  
FORI / HOLES  
AGUJEROS

245 mm x 10 mm  
9,65" x 0,39"

CINGHIA DI RALLENTAMENTO FOGLI PER:  
SHEET SLOWDOWN BELT FOR:  
CORREA PARA REDUCIR LA MARCHA DE LA HOJA PARA:

**SPEEDMASTER 75XL/102/105XL/106XL/145XL/162XL**

COMPATIBLE WITH OEM CODE

CODICE - CODE - CÓDIGO

**F4.614.570**

**6036-B**

**GRIGIA**  
**GREY**  
**GRIS**



**34**  
**FORI / HOLES**  
**AGUJEROS**

245 mm x 10 mm  
9,65" x 0,39"

**CINGHIA DI RALLENTAMENTO FOGLI RIALZATA PER:**  
**RAISED SHEET SLOWDOWN BELT FOR:**  
**CORREA REALZADA PARA REDUCIR LA MARCHA DE LA HOJA PARA:**

**SPEEDMASTER 75XL/102/105XL/106XL/145XL/162XL**

COMPATIBLE WITH OEM CODE

CODICE - CODE - CÓDIGO

**F4.614.862F**

**6036-C**

**GIALLA**  
**YELLOW**  
**AMARILLA**



**34**  
**FORI / HOLES**  
**AGUJEROS**

245 mm x 10 mm  
9,65" x 0,39"

**CINGHIA DI RALLENTAMENTO FOGLI PER:**  
**SHEET SLOWDOWN BELT FOR:**  
**CORREA PARA REDUCIR LA MARCHA DE LA HOJA PARA:**

**SPEEDMASTER 75XL/102/105XL/106XL/145XL/162XL**

COMPATIBLE WITH OEM CODE

CODICE - CODE - CÓDIGO

**F4.614.885F**

**6036-D**

**ROSA**  
**PINK**

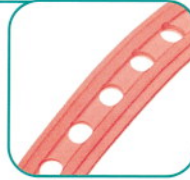

**34**  
**FORI / HOLES**  
**AGUJEROS**

245 mm x 10 mm  
9,65" x 0,39"

**CINGHIA DI RALLENTAMENTO FOGLI PER:**  
**SHEET SLOWDOWN BELT FOR:**  
**CORREA PARA REDUCIR LA MARCHA DE LA HOJA PARA:**

**SPEEDMASTER 75XL/102/105XL/106XL/145XL/162XL**

COMPATIBLE WITH OEM CODE

CODICE - CODE - CÓDIGO

**F4.614.891F**

**6036-E**

**BLU**  
**BLUE**  
**AZUL**



**34**  
**FORI / HOLES**  
**AGUJEROS**

245 mm x 10 mm  
9,65" x 0,39"

**CINGHIA DI RALLENTAMENTO FOGLI RIALZATA PER:**  
**RAISED SHEET SLOWDOWN BELT FOR:**  
**CORREA REALZADA PARA REDUCIR LA MARCHA DE LA HOJA PARA:**

**SPEEDMASTER 52/74/102/105XL**

COMPATIBLE WITH OEM CODE

CODICE - CODE - CÓDIGO

**F4.614.871**

**6036-F**

**VERDE**  
**GREEN**  
**VERDE**



**6027-A** 240 mm x 3 mm  
9,45" x 0,12"  
**6027-B** 270 mm x 3 mm  
10,63" x 0,12"  
**6027-C** 210 mm x 3 mm  
8,27" x 0,12"

**CINGHIA DI RALLENTAMENTO FOGLI PER:**  
**SHEET SLOWDOWN BELT FOR:**  
**CORREA PARA REDUCIR LA MARCHA DE LA HOJA PARA:**

**SPEEDMASTER 102/SM 74/SM 52**

COMPATIBLE WITH OEM CODE

CODICE - CODE - CÓDIGO

**6027-A**

**6027-B**

**6027-C**

**GIALLA**  
**YELLOW**  
**AMARILLA**



**30**  
**FORI / HOLES**  
**AGUJEROS**

215 mm x 38 mm  
8,46" x 1,50"

**CINGHIA DI RALLENTAMENTO COMPRIMIBILE PER:**  
**COMPRESSIBLE SLOWDOWN BELT FOR:**  
**CORREA COMPRIMIBILE PARA REALENTAR PARA:**

**SPEEDMASTER 102/102CD**

COMPATIBLE WITH OEM CODE

CODICE - CODE - CÓDIGO

**C3.015.653**

**6035**

# SUPERIOR MAGNIFYING GLASSES

LENTINI E MICROSCOPI ILLUMINATI - MAGNIFYING GLASSES  
CUENTAHILOS Y MICROSCOPIOS ILUMINADOS



**NEW**



**NEW**



**MASTER MAG** | CODICE - CODE - CÓDIGO  
( 12x + LIGHT ) | **13536**

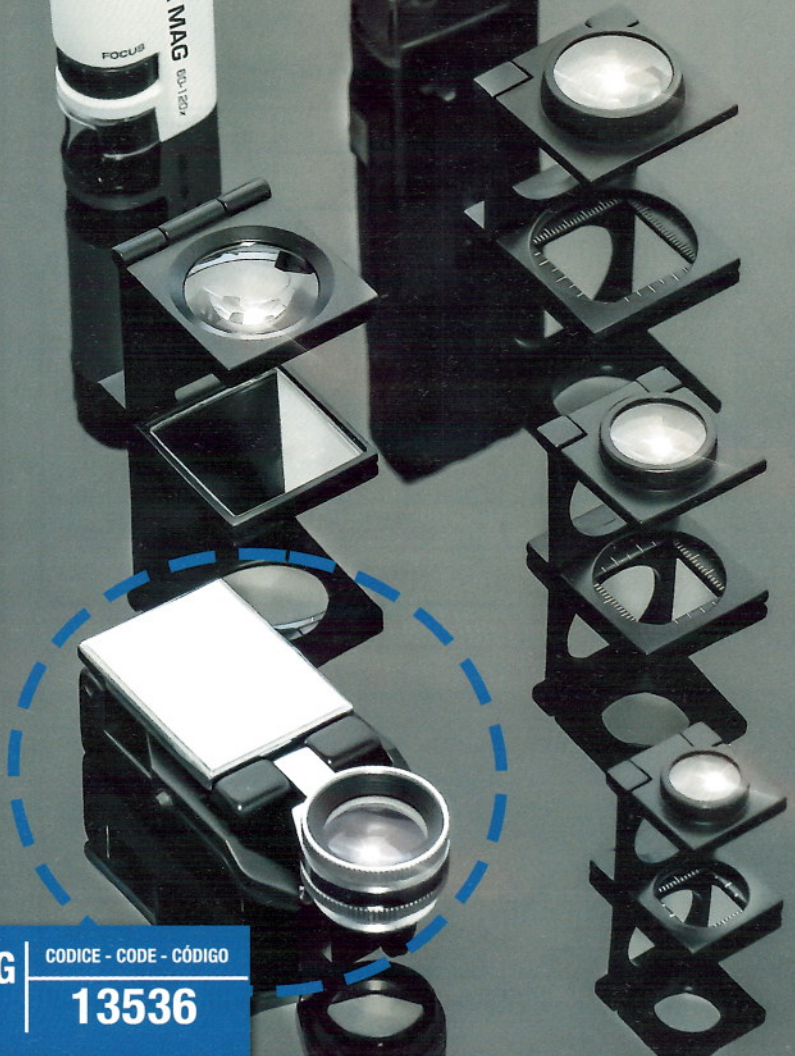

**NEW**

**SPACE MAG** | CODICE - CODE - CÓDIGO  
( 10x + LIGHT ) | **13531**



**ULTRA MAG** | CODICE - CODE - CÓDIGO  
( 60x - 120x + LIGHT ) | **13533**

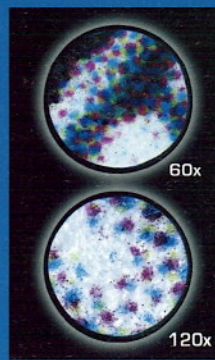

**NEW**



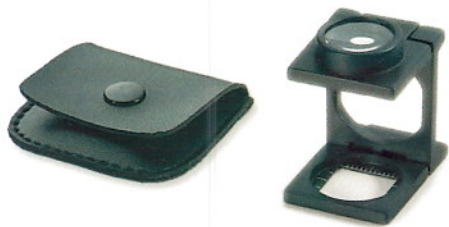

CODICE CODE - CÓDIGO	MISURA SIZE - MEDIDA	INGRANDIMENTI ENLARGEMENTS - AUMENTOS
<b>13501</b>	<b>15x15</b>	<b>10</b>



CODICE CODE - CÓDIGO	MISURA SIZE - MEDIDA	INGRANDIMENTI ENLARGEMENTS - AUMENTOS
<b>13505</b>	<b>20x20</b>	<b>8</b>



CODICE CODE - CÓDIGO	MISURA SIZE - MEDIDA	INGRANDIMENTI ENLARGEMENTS - AUMENTOS
<b>13507</b>	<b>25x25</b>	<b>6</b>



CODICE CODE - CÓDIGO	MICROSCOPIO ILLUMINATO MICROSCOPE WITH LIGHT MICROSCOPIO ILUMINADO	INGRANDIMENTI ENLARGEMENTS - AUMENTOS
<b>13525</b>		<b>50</b>



**PERSONALIZZABILE - CUSTOMIZABLE - PERSONALIZABLE**



CODICE CODE - CÓDIGO	MISURA SIZE - MEDIDA	INGRANDIMENTI ENLARGEMENTS - AUMENTOS
<b>13510</b>	<b>30x30</b>	<b>6</b>



**PERSONALIZZABILE - CUSTOMIZABLE - PERSONALIZABLE**



CODICE CODE - CÓDIGO	MISURA SIZE - MEDIDA	INGRANDIMENTI ENLARGEMENTS - AUMENTOS
<b>13530</b>	<b>-</b>	<b>10</b>



Questo kit rappresenta la massima espressione della praticità e dell'eleganza. Può essere fornito sia in forma "neutra" o su richiesta con il "logo" stampato ad un colore sul lentino (30x30) e impresso a caldo sulla custodia in cuoio.

This kit represents the maximum in practicality and elegance, it may be supplied in "neutral" form or, on specific request, with the "logo" printed in one colour on the magnifying glass (30x30) and heat-printed on the leather case.

Este kit representa la maxima expresion de lo practico y de la elegancia. Se puede suministrar tanto de forma "neutra", como bajo pedido con el "logo" impreso a un color en el cuentahilos (30x30) e impreso por calor en el estuche de cuero.

CODICE CODE - CÓDIGO	MAGNIFYING GLASSES KIT	CUSTODIA + LENTINO CASE AND MAGNIFYING GLASS ESTUCHE Y CUENTAHILOS
<b>13535</b>		

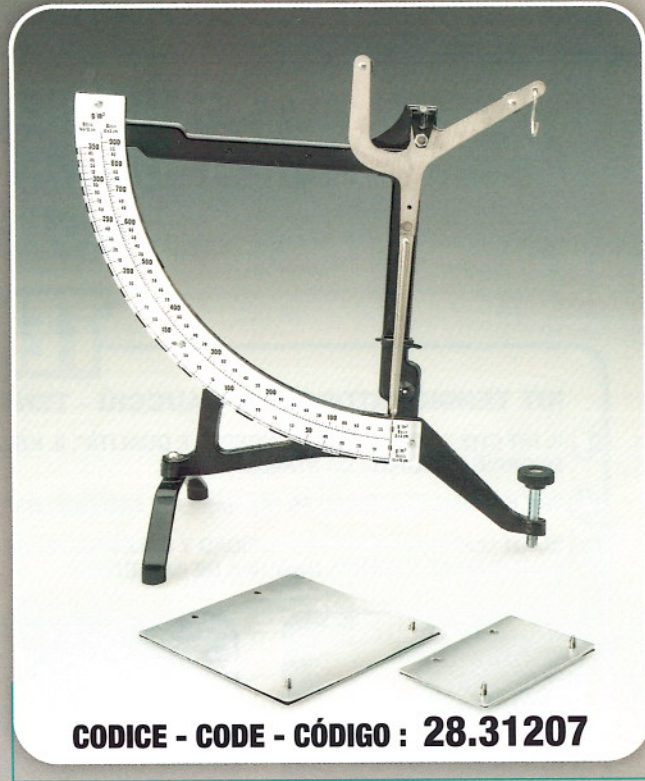

# ROYAL MEASURING AND CONTROLLING INSTRUMENTS



# STRUMENTI DI CONTROLLO E MISURAZIONE MEASURING AND CONTROLLING INSTRUMENTS INSTRUMENTOS DE CONTROL Y MEDIDA

## TENSION KIT

**KIT TENSIONATORE PER CAUCCIÙ - TENSION KIT FOR BLANKETS - KIT TENSIONADOR DE CAUCHOS**

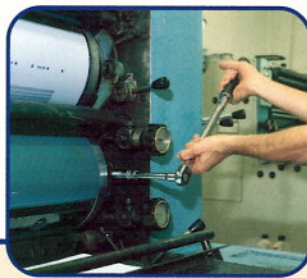

-  IL KIT CHE GARANTISCE "SICUREZZA E QUALITÀ", IL KIT CHE OGNI INDUSTRIA GRAFICA DOVREBBE EQUIPAGGIARE IN DOTAZIONE ALLE PROPRIE MACCHINE DA STAMPA
-  THE KIT THAT GUARANTEES "RELIABILITY AND QUALITY", THE KIT THAT NO PRINT-SHOP SHOULD BE WITHOUT
-  EL KIT QUE GARANTIZA "SEGURIDAD Y CALIDAD", EL KIT CON EL QUE CADA INDUSTRIA GRAFICA DEBERIA ESTAR EQUIPADO, COMO DOTACION A LA PROPIA MAQUINA DE IMPRESION



**CODICE  
CODE  
CÓDIGO  
2722580**

## TOP INDICATOR

**ALCOLOMETRO DI ALTA PRECISIONE - HIGH PRECISION ALCOHOLMETER  
ALCOHOLIMETRO DE ALTA PRECISION**



-  L'ALCOLOMETRO TOP INDICATOR® È LO STRUMENTO PIÙ ECONOMICO, PRECISO E FACILE DA UTILIZZARE INDISPENSABILE PER OGNI INDUSTRIA GRAFICA OGNI QUALVOLTA SI VOGLIA CONTROLLARE LA QUALITÀ DI ALCOOL ISOPROPILICO (IPA) NELLA SOLUZIONE DI BAGNATURA.
-  THE ALCOHOLMETER TOP INDICATOR® IS THE MOST ECONOMICAL, MOST PRECISE AND EASIEST INSTRUMENT TO USE. NO PRINTING COMPANY SHOULD BE WITHOUT ONE WHENEVER THEY NEED TO CHECK THE AMOUNT OF ISOPROPILIC ALCOHOL (IPA) IN THE FOUNTAIN SOLUTION.
-  EL ALCOHOLÍMETRO TOP INDICATOR® ES EL INSTRUMENTO MÁS ECONOMICO, PRECISO Y FACIL DE UTILIZAR, INDISPENSABLE PARA CADA INDUSTRIA GRAFICA PARA CADA VEZ QUE SE QUIERA CONTROLAR LA CALIDAD DEL ALCOHOL ISOPROPÍLICO (IPA) EN LA SOLUCIÓN DE MOJADO.



**CODICE-CODE-CÓDIGO 2722400**

## TOP UNIVERSAL INDIKATOR

**SCALA DI MISURAZIONE "PH" DA 0 A 14 - "PH" MEASURING SCALE FROM 0 TO 14 - ESCALA DE MEDICION "PH" DE 0 A 14**

-  DA SEMPRE LE PIÙ SICURE, PRECISE E AFFIDABILI STRISCE PER LA MISURAZIONE DEL "pH" DELLE SOLUZIONI DI BAGNATURA
-  ALWAYS THE SAFEST, MOST ACCURATE AND RELIABLE STRIPS FOR MEASURING THE "pH" LEVEL IN FOUNTAIN SOLUTIONS
-  DESDE SIEMPRE LA MAS SEGURA, PRECISA Y FIABLE TIRA PARA LA MEDICION DEL "pH" EN LA SOLUCION DE MOJADO

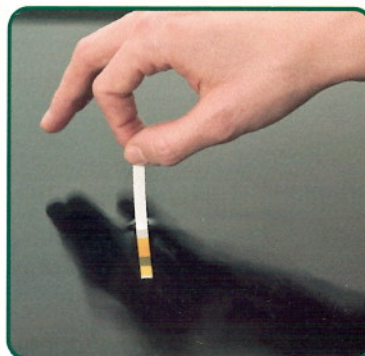

**CODICE-CODE-CÓDIGO 2722217**

**CONFEZIONE IN PLASTICA CONTENENTE 100 STRISCE GRADUATE  
PLASTIC PACKET CONTAINING 100 GRADUATED STRIPS  
CONFECCION EN PLASTICO CONTENIENDO 100 TIRAS GRADUADAS**