

IL PIÙ GRANDE PROGRAMMA DI VENTOSE MAI REALIZZATO SINO AD ORA

THE WIDEST RANGE OF SUCKERS EVER MADE

EL MAYOR PROGRAMA DE VENTOSAS QUE SE HAYA REALIZADO HASTA LA FECHA

LA MIGLIOR QUALITÀ AL MIGLIOR PREZZO  
CON IL MIGLIOR SERVIZIO

THE BEST QUALITY AT THE BEST PRICE  
WITH THE BEST SERVICE

LA MEJOR CALIDAD AL MEJOR PRECIO  
CON EL MEJOR SERVICIO



Controllo "qualità" dei vari tipi  
di mescola di gomma

Quality control of the different  
types of rubber

Control de "calidad" de los diversos tipos de  
mezclas de goma



alcune fasi della produzione • some production processes • algunas fases de la producción



FASI DEL TRATTAMENTO TERMICO LONGEVIZZANTE

PHASES OF THE THERMAL TREATMENT TO INCREASE THE LONGEVITY

FASES DE LO TRATAMIENTO TERMICO QUE ALARGA LA DURADA





# RubberTex<sup>®</sup>

## dual function suckers



HIGH PERFORMANCE, DUAL FUNCTION FLAT SUCKERS  
 PRODUCED WITH CLOTH ON ONE SIDE (FOR PAPER)  
 AND WITH SPECIAL RUBBER ON THE OTHER SIDE (FOR CARDBOARD)

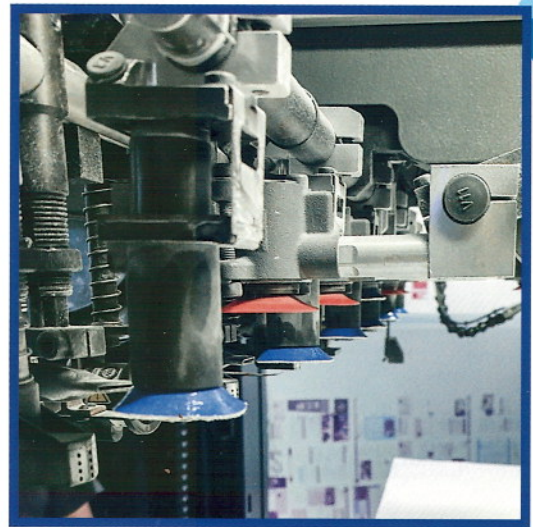
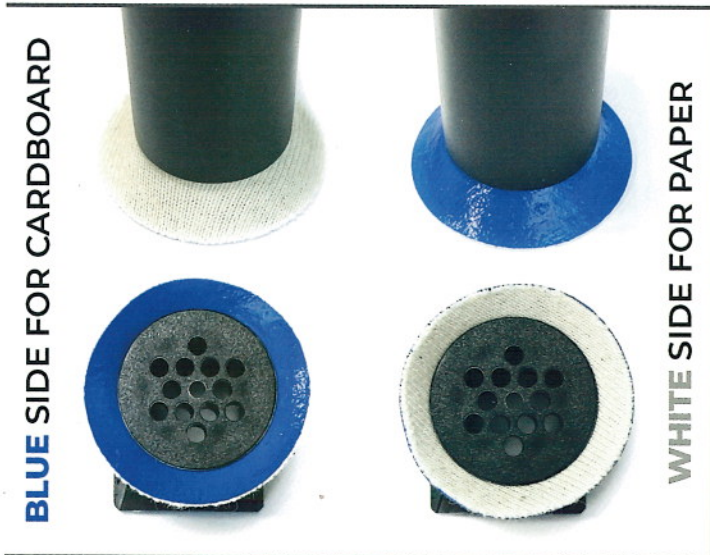

CODICE - CODE - CÓDIGO	SPESSORE THICKNESS - ESPESOR	Ø ESTERNO - Ø OUTSIDE	Ø INTERNO - Ø INSIDE
7772	RubberTex	30 mm	13 mm

CODICE - CODE - CÓDIGO	SPESSORE THICKNESS - ESPESOR	Ø ESTERNO - Ø OUTSIDE	Ø INTERNO - Ø INSIDE
8012	RubberTex	33 mm	15 mm

CODICE - CODE - CÓDIGO	SPESSORE THICKNESS - ESPESOR	Ø ESTERNO - Ø OUTSIDE	Ø INTERNO - Ø INSIDE
7932	RubberTex	32 mm	13 mm

CODICE - CODE - CÓDIGO	SPESSORE THICKNESS - ESPESOR	Ø ESTERNO - Ø OUTSIDE	Ø INTERNO - Ø INSIDE
8332	RubberTex	38 mm	14 mm

CODICE - CODE - CÓDIGO	SPESSORE THICKNESS - ESPESOR	Ø ESTERNO - Ø OUTSIDE	Ø INTERNO - Ø INSIDE
7972	RubberTex	32 mm	15 mm

CODICE - CODE - CÓDIGO	SPESSORE THICKNESS - ESPESOR	Ø ESTERNO - Ø OUTSIDE	Ø INTERNO - Ø INSIDE
8372	RubberTex	39 mm	15 mm

MISURE REALI - REAL SIZES - MEDIDAS REALES - MISURE REALI - REAL SIZES - MEDIDAS REALES



**LEGENDA COLORI E SPESSORI. COLOUR AND THICKNESS KEY. LEYENDA DE COLOR Y DE ESPESOR**

NOME - NAME	SPESSORE THICKNESS - ESPESOR
NORMAL	0,5 mm
STANDARD	0,8 mm
STANDARD SUPER RELEASE	0,8 mm
BIS	1,0 mm
BIS SUPER RELEASE	1,0 mm

NOME - NAME	SPESSORE THICKNESS - ESPESOR
ULTRA	1,5 mm
SUPER	2,0 mm
SILICONE	1,0 mm
SILICONE	1,5 mm
SILICONE	2,0 mm

GOMMA NATURALE  
NATURAL RUBBER  
CAUCHO NATURAL

**NORMAL**



SPESSORE/THICKNESS/ESPESOR  
**0,5 mm - 0,20"**

GOMMA NATURALE COLORATA  
COLOURED NATURAL RUBBER  
CAUCHO NATURAL COLOREADO

**STANDARD**



SPESSORE/THICKNESS/ESPESOR  
**0,8 mm - 0,31"**

GOMMA NATURALE COLORATA  
COLOURED NATURAL RUBBER  
CAUCHO NATURAL COLOREADO

**STANDARD SUPER RELEASE**



SPESSORE/THICKNESS/ESPESOR  
**0,8 mm - 0,31"**

GOMMA NATURALE COLORATA  
COLOURED NATURAL RUBBER  
CAUCHO NATURAL COLOREADO

**BIS**



SPESSORE/THICKNESS/ESPESOR  
**1,0 mm - 0,40"**

GOMMA NATURALE COLORATA  
COLOURED NATURAL RUBBER  
CAUCHO NATURAL COLOREADO

**BIS SUPER RELEASE**



SPESSORE/THICKNESS/ESPESOR  
**1,0 mm - 0,40"**

GOMMA NATURALE  
NATURAL RUBBER  
CAUCHO NATURAL

**ULTRA**



SPESSORE/THICKNESS/ESPESOR  
**1,5 mm - 0,60"**

GOMMA NATURALE  
NATURAL RUBBER  
CAUCHO NATURAL

**SUPER**



SPESSORE/THICKNESS/ESPESOR  
**2,0 mm - 0,80"**

SILICONE

**SILICONE**



SPESSORE/THICKNESS/ESPESOR  
**1,0 mm - 0,40"**

SILICONE

**SILICONE**



SPESSORE/THICKNESS/ESPESOR  
**1,5 mm - 0,60"**

RUBBER TEX

**SPECIAL**

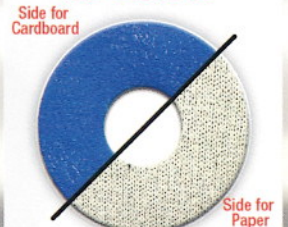

Rubbertext Thickness



# VENTOSE PIATTE - FLAT SUCKERS - VENTOSAS PLANAS



NOME - NAME - NOMBRE	SPESSORE THICKNESS - ESPESOR
NORMAL	0,5 mm
STANDARD	0,8 mm
STANDARD SUPER RELEASE	0,8 mm
BIS	1,0 mm
BIS SUPER RELEASE	1,0 mm
ULTRA	1,5 mm
SUPER	2,0 mm
SILICONE	1,0 mm
SILICONE	1,5 mm
SILICONE	2,0 mm

MISURE REALI - REAL SIZES - MEDIDAS REALES - MISURE REALI - REAL SIZES - MEDIDAS REALES - MISURE REALI - REAL SIZES - MEDIDAS REALES

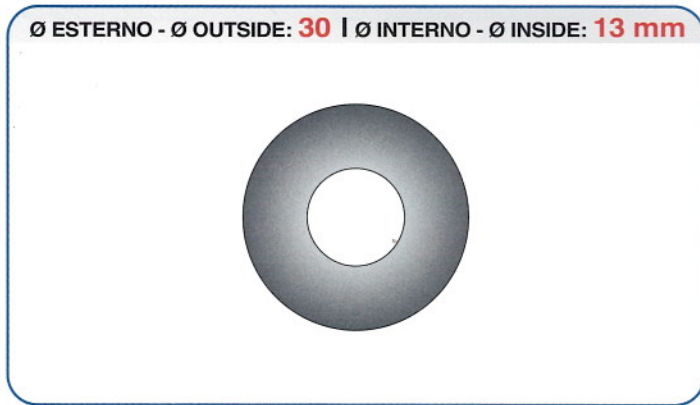

CODICE - CODE - CÓDIGO	SPESSORE THICKNESS - ESPESOR
7760	0,5 mm
7762	0,8 mm
7763	0,8 mm
7764	1,0 mm
7765	1,0 mm

CODICE - CODE - CÓDIGO	SPESSORE THICKNESS - ESPESOR
7766	1,5 mm
7768	2,0 mm
7770	1,0 mm
7771	1,5 mm

CODICE - CODE - CÓDIGO	SPESSORE THICKNESS - ESPESOR
7860	0,5 mm
7862	0,8 mm
7863	0,8 mm
7864	1,0 mm
7865	1,0 mm

CODICE - CODE - CÓDIGO	SPESSORE THICKNESS - ESPESOR
7866	1,5 mm
7868	2,0 mm
7869	1,0 mm
7870	1,5 mm

MISURE REALI - REAL SIZES - MEDIDAS REALES - MISURE REALI - REAL SIZES - MEDIDAS REALES - MISURE REALI - REAL SIZES - MEDIDAS REALES



CODICE - CODE - CÓDIGO	SPESSORE THICKNESS - ESPESOR
7920	0,5 mm
7922	0,8 mm
7923	0,8 mm
7924	1,0 mm
7925	1,0 mm

CODICE - CODE - CÓDIGO	SPESSORE THICKNESS - ESPESOR
7926	1,5 mm
7928	2,0 mm
7930	1,0 mm
7931	1,5 mm

CODICE - CODE - CÓDIGO	SPESSORE THICKNESS - ESPESOR
8000	0,5 mm
8002	0,8 mm
8003	0,8 mm
8004	1,0 mm
8005	1,0 mm

CODICE - CODE - CÓDIGO	SPESSORE THICKNESS - ESPESOR
8006	1,5 mm
8008	2,0 mm
8009	1,0 mm
8010	1,5 mm

È vietata la riproduzione di ogni singola o parziale fotografia del presente catalogo, tutti i diritti sono riservati. - Any reproduction in whole or in part of this catalogue, is strictly prohibited. All rights reserved. - Se prohíbe terminantemente la reproducción total o parcial de cada fotografía contenida en este catálogo. Todos los derechos están reservados. ممنوع الأستنساخ من كل أو بعض هذا الدليل منعاً باتاً لكل الحقوق محفوظة



Ø ESTERNO - Ø OUTSIDE: **35** | Ø INTERNO - Ø INSIDE: **10 mm**



CODICE - CODE - CÓDIGO	SPESSORE THICKNESS - ESPESOR
8080	0,5 mm
8082	0,8 mm
8083	0,8 mm
8084	1,0 mm
8085	1,0 mm

CODICE - CODE - CÓDIGO	SPESSORE THICKNESS - ESPESOR
8086	1,5 mm
8088	2,0 mm
8089	1,0 mm
8090	1,5 mm

Ø ESTERNO - Ø OUTSIDE: **35** | Ø INTERNO - Ø INSIDE: **15 mm**

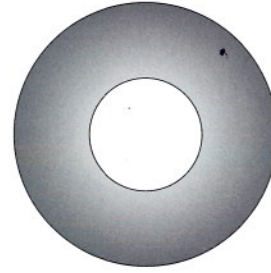

CODICE - CODE - CÓDIGO	SPESSORE THICKNESS - ESPESOR
8160	0,5 mm
8162	0,8 mm
8163	0,8 mm
8164	1,0 mm
8165	1,0 mm

CODICE - CODE - CÓDIGO	SPESSORE THICKNESS - ESPESOR
8166	1,5 mm
8168	2,0 mm
8169	1,0 mm
8170	1,5 mm

MISURE REALI - REAL SIZES - MEDIDAS REALES - MISURE REALI - REAL SIZES - MEDIDAS REALES - MISURE REALI - REAL SIZES - MEDIDAS REALES

Ø ESTERNO - Ø OUTSIDE: **36** | Ø INTERNO - Ø INSIDE: **15 mm**

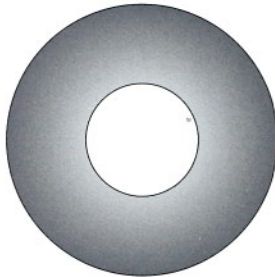

CODICE - CODE - CÓDIGO	SPESSORE THICKNESS - ESPESOR
8180	0,5 mm
8182	0,8 mm
8183	0,8 mm
8184	1,0 mm
8185	1,0 mm

CODICE - CODE - CÓDIGO	SPESSORE THICKNESS - ESPESOR
8186	1,5 mm
8188	2,0 mm
8189	1,0 mm
8190	1,5 mm

Ø ESTERNO - Ø OUTSIDE: **38** | Ø INTERNO - Ø INSIDE: **10 mm**



CODICE - CODE - CÓDIGO	SPESSORE THICKNESS - ESPESOR
8240	0,5 mm
8242	0,8 mm
8243	0,8 mm
8244	1,0 mm
8245	1,0 mm

CODICE - CODE - CÓDIGO	SPESSORE THICKNESS - ESPESOR
8246	1,5 mm
8248	2,0 mm
8249	1,0 mm
8250	1,5 mm

MISURE REALI - REAL SIZES - MEDIDAS REALES - MISURE REALI - REAL SIZES - MEDIDAS REALES - MISURE REALI - REAL SIZES - MEDIDAS REALES

Ø ESTERNO - Ø OUTSIDE: **38** | Ø INTERNO - Ø INSIDE: **14 mm**



CODICE - CODE - CÓDIGO	SPESSORE THICKNESS - ESPESOR
8320	0,5 mm
8322	0,8 mm
8323	0,8 mm
8324	1,0 mm
8325	1,0 mm

CODICE - CODE - CÓDIGO	SPESSORE THICKNESS - ESPESOR
8326	1,5 mm
8328	2,0 mm
8330	1,0 mm
8329	1,5 mm
8330A Polyurethane	1,0 mm

Ø ESTERNO - Ø OUTSIDE: **38** | Ø INTERNO - Ø INSIDE: **15 mm**

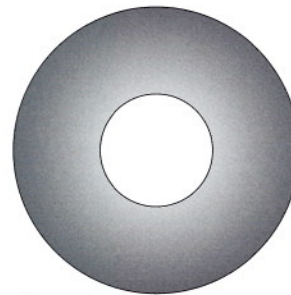

CODICE - CODE - CÓDIGO	SPESSORE THICKNESS - ESPESOR
8340	0,5 mm
8342	0,8 mm
8343	0,8 mm
8344	1,0 mm
8345	1,0 mm

CODICE - CODE - CÓDIGO	SPESSORE THICKNESS - ESPESOR
8346	1,5 mm
8348	2,0 mm
8349	1,0 mm
8350	1,5 mm
8350A Polyurethane	1,0 mm



Ø ESTERNO - Ø OUTSIDE: **39** | Ø INTERNO - Ø INSIDE: **15 mm**

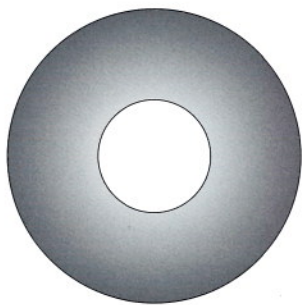

Ø ESTERNO - Ø OUTSIDE: **40** | Ø INTERNO - Ø INSIDE: **9 mm**



CODICE - CODE - CÓDIGO	SPESSORE THICKNESS - ESPESOR
8360	0,5 mm
8362	0,8 mm
8363	0,8 mm
8364	1,0 mm
8365	1,0 mm

CODICE - CODE - CÓDIGO	SPESSORE THICKNESS - ESPESOR
8366	1,5 mm
8368	2,0 mm
8369	1,0 mm
8370	1,5 mm

CODICE - CODE - CÓDIGO	SPESSORE THICKNESS - ESPESOR
8380	0,5 mm
8382	0,8 mm
8383	0,8 mm
8384	1,0 mm
8385	1,0 mm

CODICE - CODE - CÓDIGO	SPESSORE THICKNESS - ESPESOR
8386	1,5 mm
8388	2,0 mm
8389	1,0 mm
8390	1,5 mm

MISURE REALI - REAL SIZES - MEDIDAS REALES - MISURE REALI - REAL SIZES - MEDIDAS REALES - MISURE REALI - REAL SIZES - MEDIDAS REALES

Ø ESTERNO - Ø OUTSIDE: **45** | Ø INTERNO - Ø INSIDE: **14 mm**



Ø ESTERNO - Ø OUTSIDE: **45** | Ø INTERNO - Ø INSIDE: **15 mm**

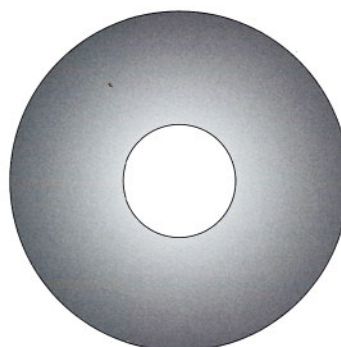

CODICE - CODE - CÓDIGO	SPESSORE THICKNESS - ESPESOR
8520	0,5 mm
8522	0,8 mm
8523	0,8 mm
8524	1,0 mm
8525	1,0 mm

CODICE - CODE - CÓDIGO	SPESSORE THICKNESS - ESPESOR
8526	1,5 mm
8528	2,0 mm
8529	1,0 mm
8530	1,5 mm

CODICE - CODE - CÓDIGO	SPESSORE THICKNESS - ESPESOR
8540	0,5 mm
8542	0,8 mm
8543	0,8 mm
8544	1,0 mm
8545	1,0 mm

CODICE - CODE - CÓDIGO	SPESSORE THICKNESS - ESPESOR
8546	1,5 mm
8548	2,0 mm
8549	1,0 mm
8550	1,5 mm
8552	2,0 mm

MISURE REALI - REAL SIZES - MEDIDAS REALES - MISURE REALI - REAL SIZES - MEDIDAS REALES - MISURE REALI - REAL SIZES - MEDIDAS REALES



# VENTOSE SAGOMATE - SHAPED SUCKERS - VENTOSAS MOLDEADAS

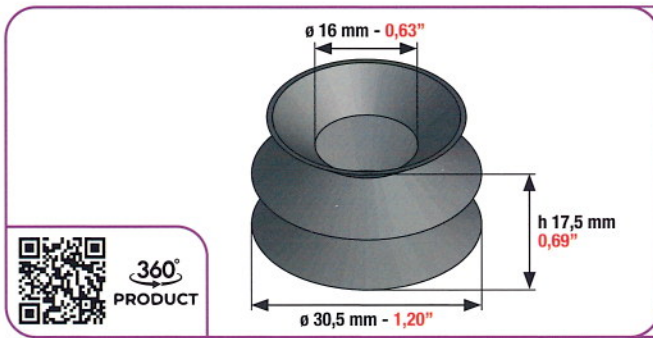

CODE - CODICE - CODIGO  
**9066**

**ROLAND 700/900**



**9066 WHITE**



**9066 POLYURETHANE**



**9066 TRANSPARENT**

MISURE REALI - REAL SIZE - MEDIDAS REALES

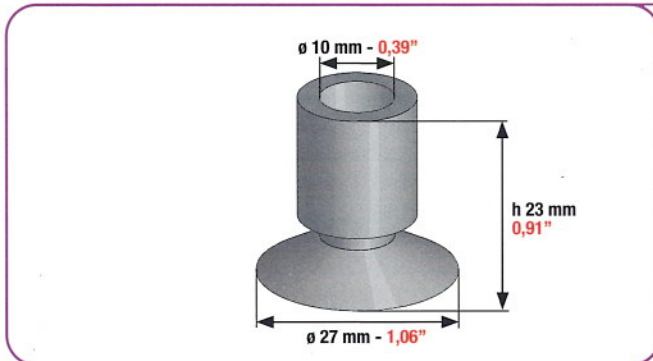

CODE - CODICE - CODIGO  
**9037 RED**

**ROLAND**

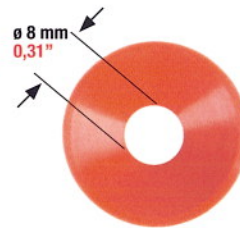

MISURE REALI - REAL SIZE - MEDIDAS REALES

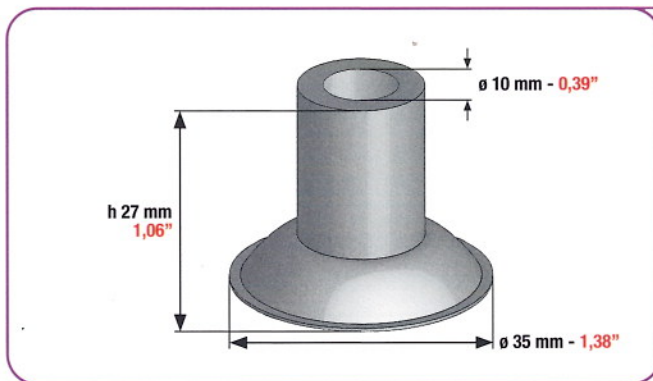

CODE - CODICE - CODIGO  
**9046 RED**

**ROLAND**

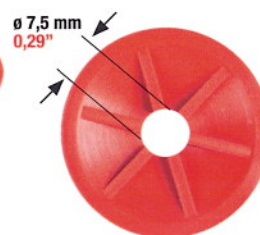
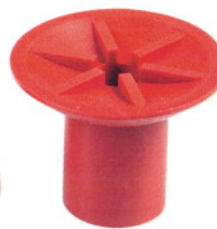

MISURE REALI - REAL SIZE - MEDIDAS REALES

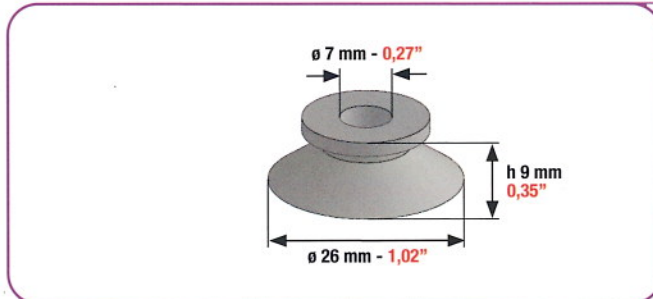

CODE - CODICE - CODIGO  
**9030 BLACK**

**ROLAND**

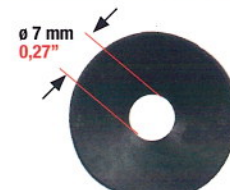

MISURE REALI - REAL SIZE - MEDIDAS REALES

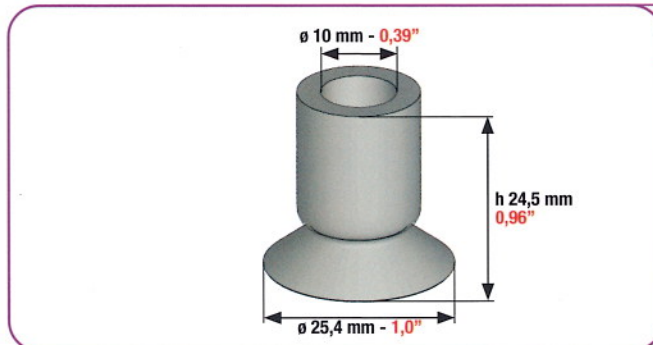

CODE - CODICE - CODIGO  
**9082 RED**

**ROLAND**

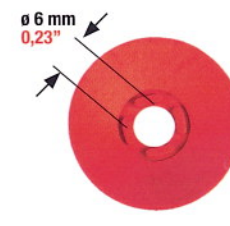

È vietata la riproduzione di ogni singola o parziale fotografia del presente catalogo, tutti i diritti sono riservati. - Any reproduction in whole or in part of this catalogue, is strictly prohibited. All rights reserved. - Se prohíbe terminantemente la reproducción total o parcial de cada fotografía contenida en este catálogo. Todos los derechos están reservados.

ممنوع الاستنساخ من كل أو بعض هذا الدليل منعاً باتاً. كل الحقوق محفوظة



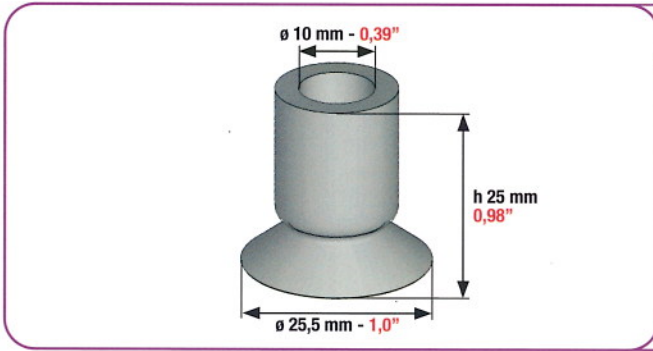

CODE - CODICE - CODIGO  
**9083 RED**

**ROLAND**



MISURE REALI - REAL SIZE - MEDIDAS REALES

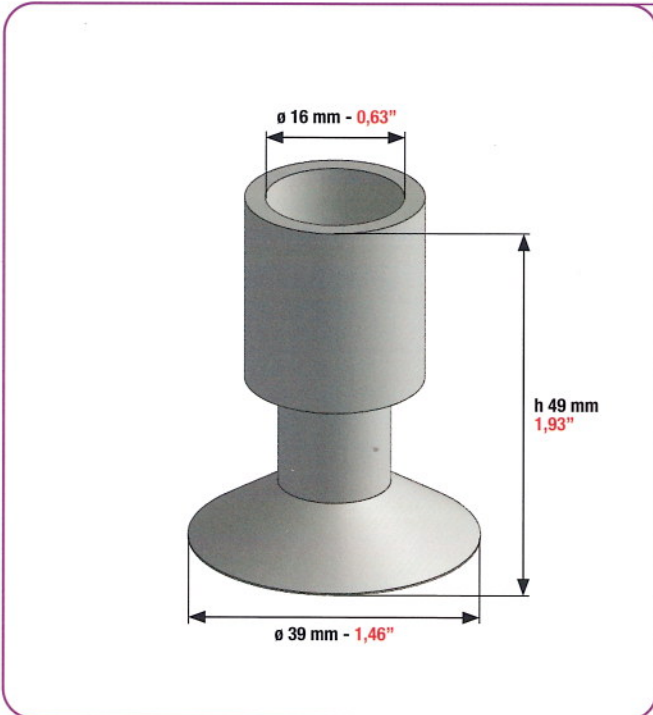

CODE - CODICE - CODIGO  
**9097**

**MIEHLE / ROLAND**

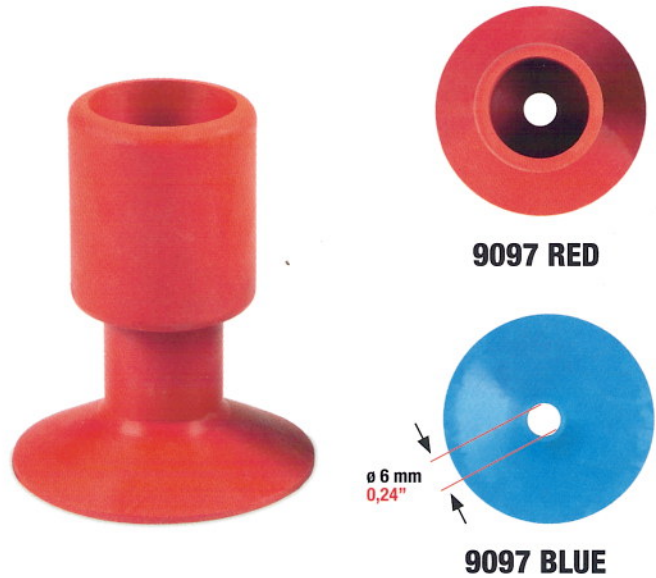

MISURE REALI - REAL SIZE - MEDIDAS REALES

MISURE REALI - REAL SIZE - MEDIDAS REALES





**BOCCHETTA DI SOLLEVAMENTO  
LIFTING SUPPORT FOR SUCKERS  
SOPORTE DE ALZADO DE VENTOSAS**

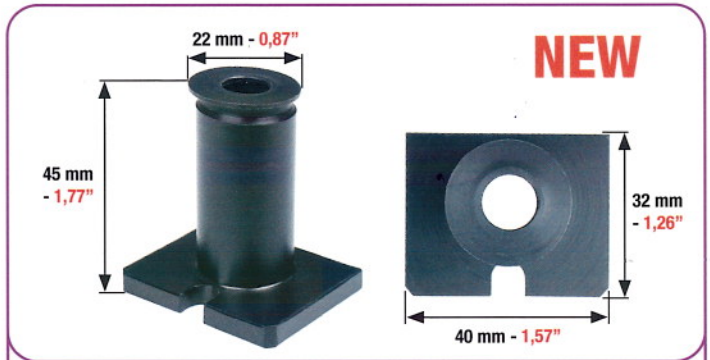

**NEW**

**BOCCHETTA DI SOLLEVAMENTO PER:  
LIFTING SUPPORT FOR SUCKERS FOR:  
SOPORTE DE ALZADO DE VENTOSAS PARA:**

**MABEG / ROLAND 700**

ORDINE MINIMO 2 PEZZI  
MINIMUM ORDER 2 PCS  
PEDIDO MÍNIMO 2 PIEZAS

CODICE  
CODE - CÓDIGO  
**48111**

**PER CARTA - FOR PAPER - PARA PAPEL**



**BOCCHETTA DI SOLLEVAMENTO PER:  
LIFTING SUPPORT FOR SUCKERS FOR:  
SOPORTE DE ALZADO DE VENTOSAS PARA:**

**ROLAND - MABEG**

ORDINE MINIMO 2 PEZZI  
MINIMUM ORDER 2 PCS  
PEDIDO MÍNIMO 2 PIEZAS

CODICE  
CODE - CÓDIGO  
**4831**

**PER CARTONE - FOR CARDBOARD - PARA CARTÓN**

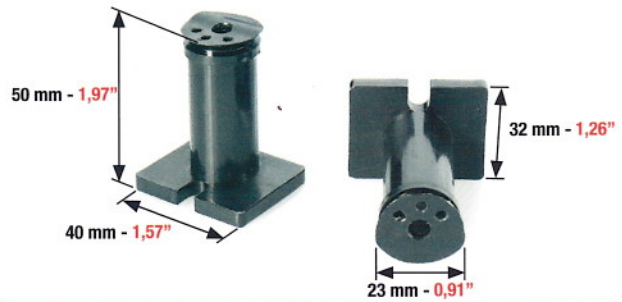

**BOCCHETTA DI SOLLEVAMENTO PER:  
LIFTING SUPPORT FOR SUCKERS FOR:  
SOPORTE DE ALZADO DE VENTOSAS PARA:**

**ROLAND - MABEG**

ORDINE MINIMO 2 PEZZI  
MINIMUM ORDER 2 PCS  
PEDIDO MÍNIMO 2 PIEZAS

CODICE  
CODE - CÓDIGO  
**4832**

**PER CARTA - FOR PAPER - PARA PAPEL**

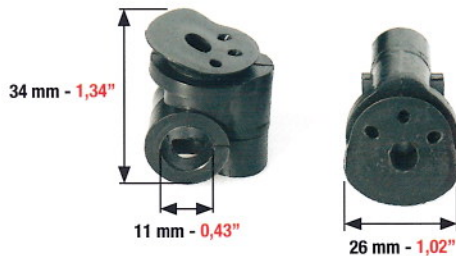

**BOCCHETTA DI SOLLEVAMENTO PER:  
LIFTING SUPPORT FOR SUCKERS FOR:  
SOPORTE DE ALZADO DE VENTOSAS PARA:**

**ROLAND ULTRA - MABEG**

ORDINE MINIMO 2 PEZZI  
MINIMUM ORDER 2 PCS  
PEDIDO MÍNIMO 2 PIEZAS

CODICE  
CODE - CÓDIGO  
**4826**

**PER CARTONE - FOR CARDBOARD - PARA CARTÓN**

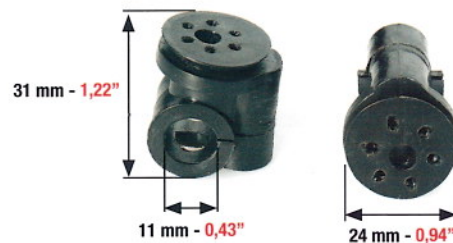

**BOCCHETTA DI SOLLEVAMENTO PER:  
LIFTING SUPPORT FOR SUCKERS FOR:  
SOPORTE DE ALZADO DE VENTOSAS PARA:**

**ROLAND ULTRA - MABEG**

ORDINE MINIMO 2 PEZZI  
MINIMUM ORDER 2 PCS  
PEDIDO MÍNIMO 2 PIEZAS

CODICE  
CODE - CÓDIGO  
**4827**



**PER CARTA - FOR PAPER - PARA PAPEL**



**BOCCHETTA DI SOLLEVAMENTO PER:  
LIFTING SUPPORT FOR SUCKERS FOR:  
SOPORTE DE ALZADO DE VENTOSAS PARA:**

**MABEG**

ORDINE MINIMO 2 PEZZI  
MINIMUM ORDER 2 PCS  
PEDIDO MÍNIMO 2 PIEZAS

CODICE  
CODE - CÓDIGO  
**4816**

**PER CARTONE - FOR CARDBOARD - PARA CARTÓN**



**BOCCHETTA DI SOLLEVAMENTO PER:  
LIFTING SUPPORT FOR SUCKERS FOR:  
SOPORTE DE ALZADO DE VENTOSAS PARA:**

**MABEG**

ORDINE MINIMO 2 PEZZI  
MINIMUM ORDER 2 PCS  
PEDIDO MÍNIMO 2 PIEZAS

CODICE  
CODE - CÓDIGO  
**4817**

**PER CARTA - FOR PAPER - PARA PAPEL**

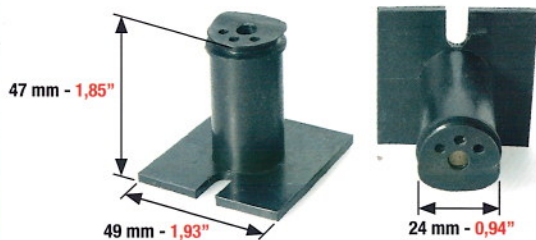

**BOCCHETTA DI SOLLEVAMENTO PER:  
LIFTING SUPPORT FOR SUCKERS FOR:  
SOPORTE DE ALZADO DE VENTOSAS PARA:**

**MABEG**

ORDINE MINIMO 2 PEZZI  
MINIMUM ORDER 2 PCS  
PEDIDO MÍNIMO 2 PIEZAS

CODICE  
CODE - CÓDIGO  
**4818**

**PER CARTONE - FOR CARDBOARD - PARA CARTÓN**

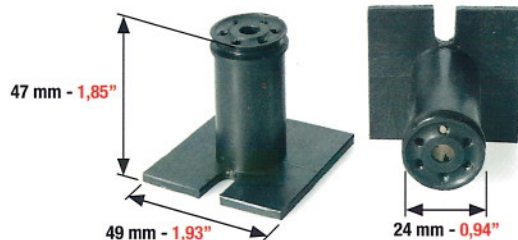

**BOCCHETTA DI SOLLEVAMENTO PER:  
LIFTING SUPPORT FOR SUCKERS FOR:  
SOPORTE DE ALZADO DE VENTOSAS PARA:**

**MABEG**

ORDINE MINIMO 2 PEZZI  
MINIMUM ORDER 2 PCS  
PEDIDO MÍNIMO 2 PIEZAS

CODICE  
CODE - CÓDIGO  
**4819**

**PER CARTONE - FOR CARDBOARD - PARA CARTÓN**



**BOCCHETTA DI SOLLEVAMENTO PER:  
LIFTING SUPPORT FOR SUCKERS FOR:  
SOPORTE DE ALZADO DE VENTOSAS PARA:**

**MABEG**

ORDINE MINIMO 2 PEZZI  
MINIMUM ORDER 2 PCS  
PEDIDO MÍNIMO 2 PIEZAS

CODICE  
CODE - CÓDIGO  
**4833**

**PER CARTONE - FOR CARDBOARD - PARA CARTÓN**



**BOCCHETTA DI SOLLEVAMENTO PER:  
LIFTING SUPPORT FOR SUCKERS FOR:  
SOPORTE DE ALZADO DE VENTOSAS PARA:**

**MABEG**

ORDINE MINIMO 2 PEZZI  
MINIMUM ORDER 2 PCS  
PEDIDO MÍNIMO 2 PIEZAS

CODICE  
CODE - CÓDIGO  
**4834**



**LINGUETTE SEPARAFOGLIO  
SHEET SEPARATORS  
LENGUETAS SEPARADORAS**

**TOP QUALITY**  
PRODOTTE CON ACCIAIO SVEDESE ORIGINALE  
PRODUCED WITH ORIGINAL SWEDISH STEEL  
FABRICADAS CON ACERO SUECO ORIGINAL

42 mm - 1,65"  
31 mm - 1,22"  
15 mm - 0,59"

LINGUETTA SEPARAFOGLIO PER:  
SHEET SEPARATOR FOR:  
LENGUETA SEPARADORA PARA:

**MANROLAND**

CONFEZIONI DA 100 PEZZI 100 PCS PACKETS CONFECCIONES DE 100 PIEZAS	CODICE CODE - CÓDIGO	SPESSORE THICKNESS - GROSOR	
	4500	0,10 mm 0,004"	
	4505	0,20 mm 0,008"	
	4510	0,30 mm 0,012"	

**TOP QUALITY**  
PRODOTTE CON ACCIAIO SVEDESE ORIGINALE  
PRODUCED WITH ORIGINAL SWEDISH STEEL  
FABRICADAS CON ACERO SUECO ORIGINAL

50 mm - 1,97"  
11,5 mm - 0,45"

LINGUETTA SEPARAFOGLIO PER:  
SHEET SEPARATOR FOR:  
LENGUETA SEPARADORA PARA:

**ROLAND 700**

CONFEZIONI DA 100 PEZZI 100 PCS PACKETS CONFECCIONES DE 100 PIEZAS	CODICE CODE - CÓDIGO	SPESSORE THICKNESS - GROSOR	
	4535	0,10 mm 0,004"	
	4540	0,20 mm 0,008"	
	4549	0,30 mm 0,012"	

**TOP QUALITY**  
PRODOTTE CON ACCIAIO SVEDESE ORIGINALE  
PRODUCED WITH ORIGINAL SWEDISH STEEL  
FABRICADAS CON ACERO SUECO ORIGINAL

Set = composto da 5 linguette di diversa misura  
Set composed of 5 sheet separators of different sizes  
Juego = compuesto por 5 lengüetas de diversas medidas

A - 37 mm - 1,46"  
B - 38 mm - 1,50"  
C - 39 mm - 1,54"  
D - 40 mm - 1,57"  
E - 41 mm - 1,61"

SET COMPLETO LINGUETTE SEPARAFOGLIO PER:  
COMPLETE SET OF SHEET SEPARATORS FOR:  
JUEGO COMPLETO DE LENGUETAS SEPARADORAS DE HOJAS PARA:

**ROLAND 200/500/700/800/900**

ORDINE MINIMO 5 SET MINIMUM ORDER 5 SETS PEDIDO MÍNIMO 5 JUEGOS	CODICE CODE - CÓDIGO	SPESSORE THICKNESS - GROSOR	
	4571	0,10 mm 0,004"	
	4572	0,20 mm 0,008"	
	4573	0,30 mm 0,012"	

**TOP QUALITY**  
PRODOTTE CON ACCIAIO SVEDESE ORIGINALE  
PRODUCED WITH ORIGINAL SWEDISH STEEL  
FABRICADAS CON ACERO SUECO ORIGINAL

93 mm - 3,66"  
12 mm - 0,47"

LINGUETTA SEPARAFOGLIO PER:  
SHEET SEPARATOR FOR:  
LENGUETA SEPARADORA PARA:

**MABEG - ROLAND REKORD/600 - PRAKTICA 00/01  
TUTTI I MODELLI - ALL MODELS - TODOS LOS MODELOS**

	CODICE CODE - CÓDIGO		
	4973		





PRODOTTE CON ACCIAIO SVEDESE ORIGINALE  
PRODUCED WITH ORIGINAL SWEDISH STEEL  
FABRICADAS CON ACERO SUECO ORIGINAL

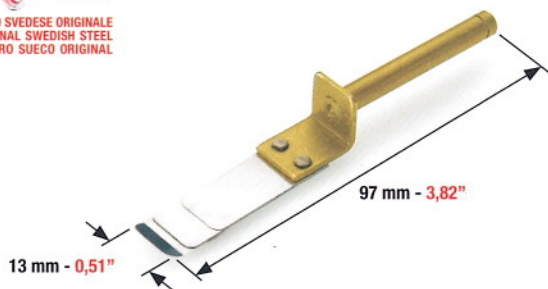

LINGUETTA SEPARAFOGLIO PER:  
SHEET SEPARATOR FOR:  
LENGÜETA SEPARADORA PARA:

**SPICE**

CODICE CODE - CÓDIGO	SPESSORE THICKNESS - GROSOR	
<b>4974</b>	0,10 mm	0,004"
<b>4975</b>	0,15 mm	0,006"



PRODOTTE CON ACCIAIO SVEDESE ORIGINALE  
PRODUCED WITH ORIGINAL SWEDISH STEEL  
FABRICADAS CON ACERO SUECO ORIGINAL

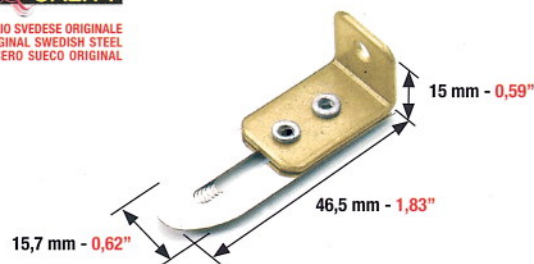

LINGUETTE SEPARAFOGLIO UNIVERSALI PER:  
UNIVERSAL SHEET SEPARATORS FOR:  
LENGÜETAS SEPARADORAS DE HOJAS UNIVERSAL PARA:

**M.A.N. - ROLAND**

ORDINE MINIMO 2 PEZZI MINIMUM ORDER 2 PCS PEDIDO MÍNIMO 2 PIEZAS	CODICE CODE - CÓDIGO	SPESSORE THICKNESS - GROSOR	
	<b>4610</b>	0,10 mm	0,004"
	<b>4615</b>	0,20 mm	0,008"
	<b>4620</b>	0,30 mm	0,012"

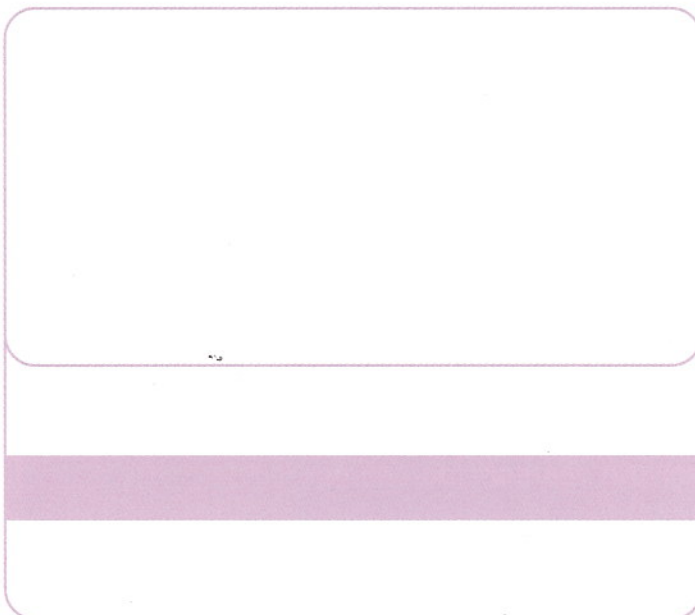
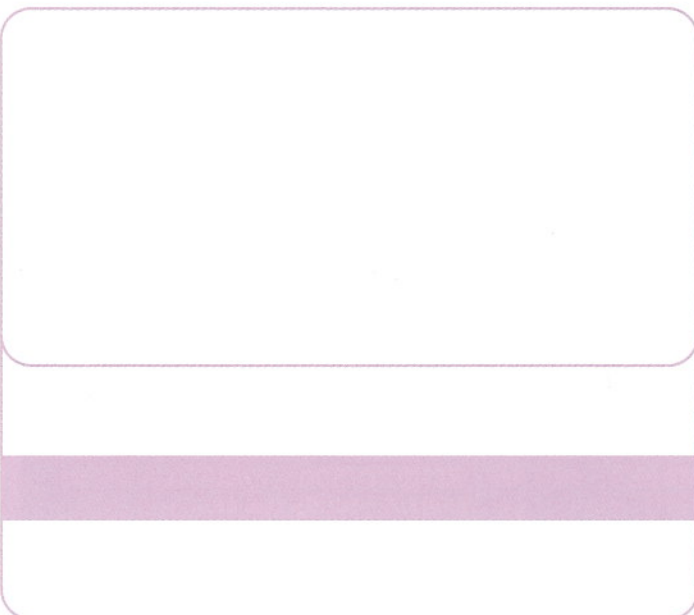
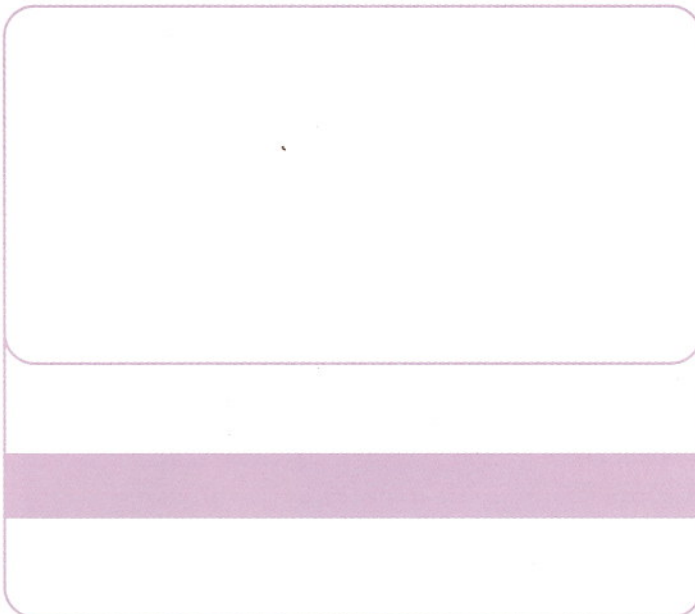

È vietata la riproduzione di ogni singola o parziale fotografia del presente catalogo, tutti i diritti sono riservati. - Any reproduction in whole or in part of this catalogue, is strictly prohibited. All rights reserved. - Se prohíbe terminantemente la reproducción total o parcial de cada fotografía contenida en este catálogo. Todos los derechos están reservados. ممنوع الأستنساخ من كل أو بعض هذا الدليل منعاً باتاً. كل الحقوق محفوظة





**SPAZZOLINI METTIFOGLIO  
FEEDER BRUSHES  
CEPILLOS PARA MARCADOR**

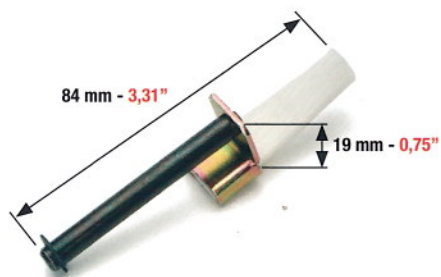

SPAZZOLINO METTIFOGLIO PER:  
FEEDER BRUSH FOR:  
CEPILLO PARA MARCADOR PARA:

**M.A.N. - ROLAND - SPIES**

ORDINE MINIMO 2 PEZZI  
MINIMUM ORDER 2 PCS  
PEDIDO MÍNIMO 2 PIEZAS

CODICE  
CODE - CÓDIGO

**4594**

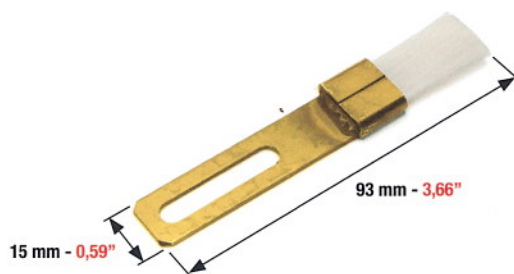

SPAZZOLINO METTIFOGLIO PER:  
FEEDER BRUSH FOR:  
CEPILLO PARA MARCADOR PARA:

**M.A.N. - ROLAND - SPIES**

ORDINE MINIMO 2 PEZZI  
MINIMUM ORDER 2 PCS  
PEDIDO MÍNIMO 2 PIEZAS

CODICE  
CODE - CÓDIGO

**4596**

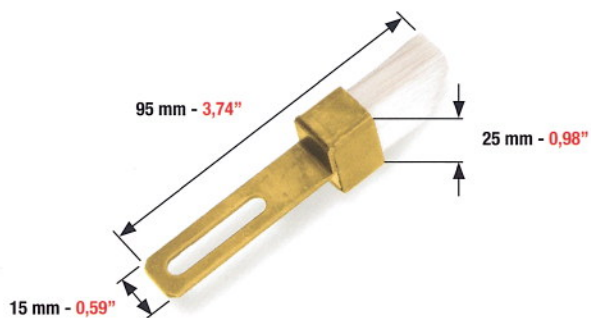

SPAZZOLINO METTIFOGLIO PER:  
FEEDER BRUSH FOR:  
CEPILLO PARA MARCADOR PARA:

**M.A.N. - ROLAND - SPIES**

ORDINE MINIMO 2 PEZZI  
MINIMUM ORDER 2 PCS  
PEDIDO MÍNIMO 2 PIEZAS

CODICE  
CODE - CÓDIGO

**4598**

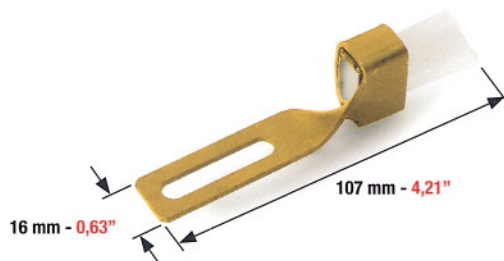

SPAZZOLINO METTIFOGLIO PER:  
FEEDER BRUSH FOR:  
CEPILLO PARA MARCADOR PARA:

**M.A.N. - ROLAND - MABEG**

ORDINE MINIMO 2 PEZZI  
MINIMUM ORDER 2 PCS  
PEDIDO MÍNIMO 2 PIEZAS

CODICE  
CODE - CÓDIGO

**4691**



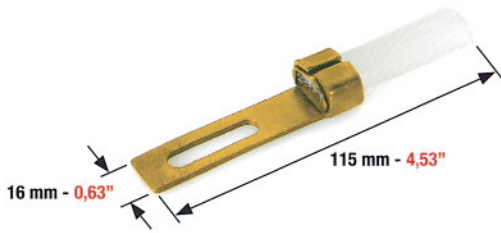

SPAZZOLINO METTIFOGLIO PER:  
FEEDER BRUSH FOR:  
CEPILLO PARA MARCADOR PARA:

**M.A.N. - ROLAND - MABEG**

ORDINE MINIMO 2 PEZZI  
MINIMUM ORDER 2 PCS  
PEDIDO MÍNIMO 2 PIEZAS

CODICE  
CODE - CÓDIGO

**4692**

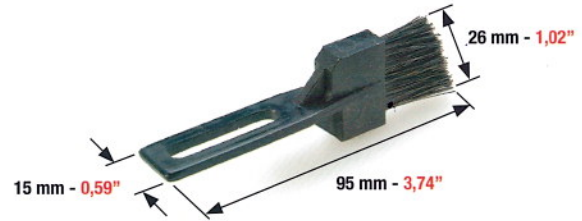

SPAZZOLINO METTIFOGLIO PER:  
FEEDER BRUSH FOR:  
CEPILLO PARA MARCADOR PARA:

**MABEG**

ORDINE MINIMO 2 PEZZI  
MINIMUM ORDER 2 PCS  
PEDIDO MÍNIMO 2 PIEZAS

CODICE  
CODE - CÓDIGO

**4663**

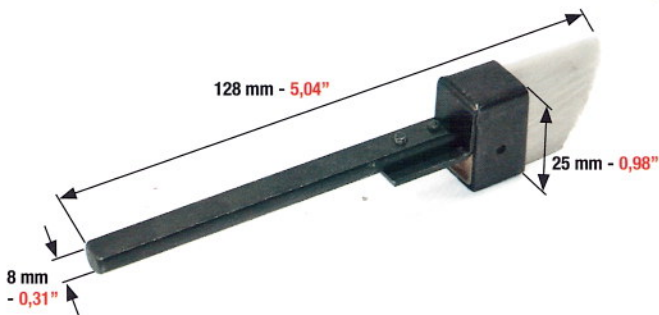

SPAZZOLINO METTIFOGLIO + TELAIO PER:  
FEEDER BRUSH + FRAME FOR:  
CEPILLO PARA MARCADOR + ARMAZON PARA:

**MANROLAND 900 - UNIVERSAL**

ORDINE MINIMO 2 PEZZI  
MINIMUM ORDER 2 PCS  
PEDIDO MÍNIMO 2 PIEZAS

CODICE  
CODE - CÓDIGO

**4598-B**

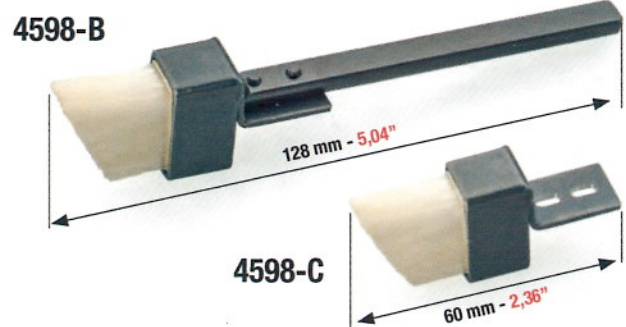

SPAZZOLINO METTIFOGLIO PER:  
FEEDER BRUSH FOR:  
CEPILLO PARA MARCADOR PARA:

**MANROLAND 900 - UNIVERSAL**

ORDINE MINIMO 2 PEZZI  
MINIMUM ORDER 2 PCS  
PEDIDO MÍNIMO 2 PIEZAS

CODICE  
CODE - CÓDIGO

**4598-C**





**TOP QUALITY**

# KIT OF AIR DIVERTERS FOR LITHOMAN

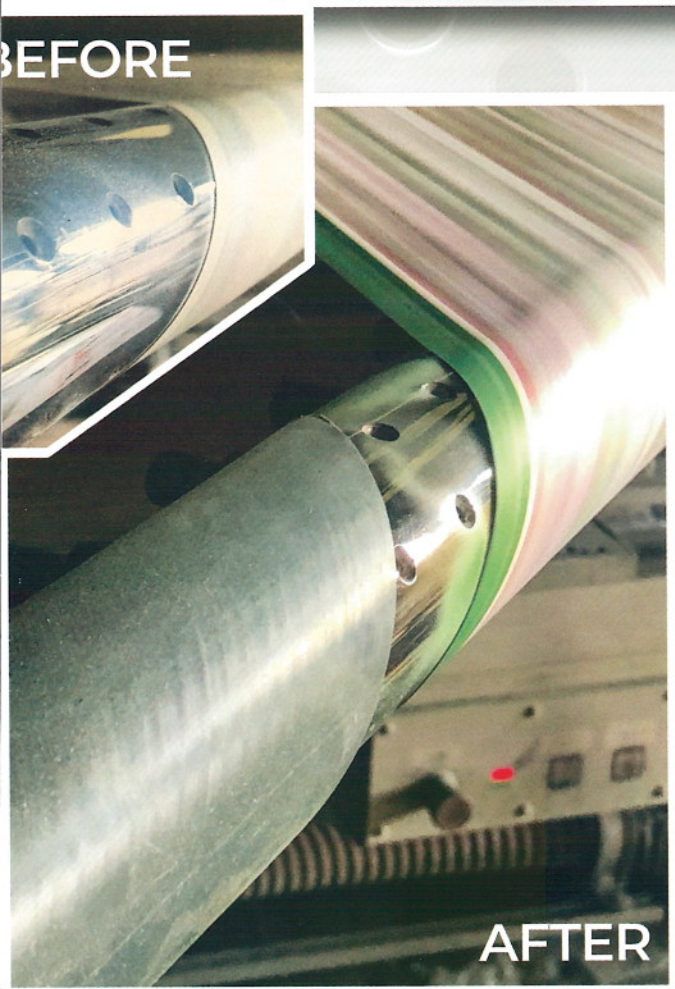

BEFORE

AFTER



**COD: 10340**

- EXCELLENT ADHERENCE
- EXCELLENT AIR DIVERSION
- OPTIMAL WEAR RESISTANCE

**COMPLETE KIT**  
**CONTAINS 6 PIECES FOR**  
**THE BEST ADAPTABILITY**

[www.pavanvr.com](http://www.pavanvr.com)



# SPAZZOLE A LISTELLO PER ROTATIVE M.A.N. ROLAND BRUSH BARS FOR WEB M.A.N. ROLAND CEPILLOS EN LISTON PARA ROTATIVA M.A.N. ROLAND ROTOMAN-POLYMAN-UNIMAN-LITHOMAN



**TOP QUALITY**

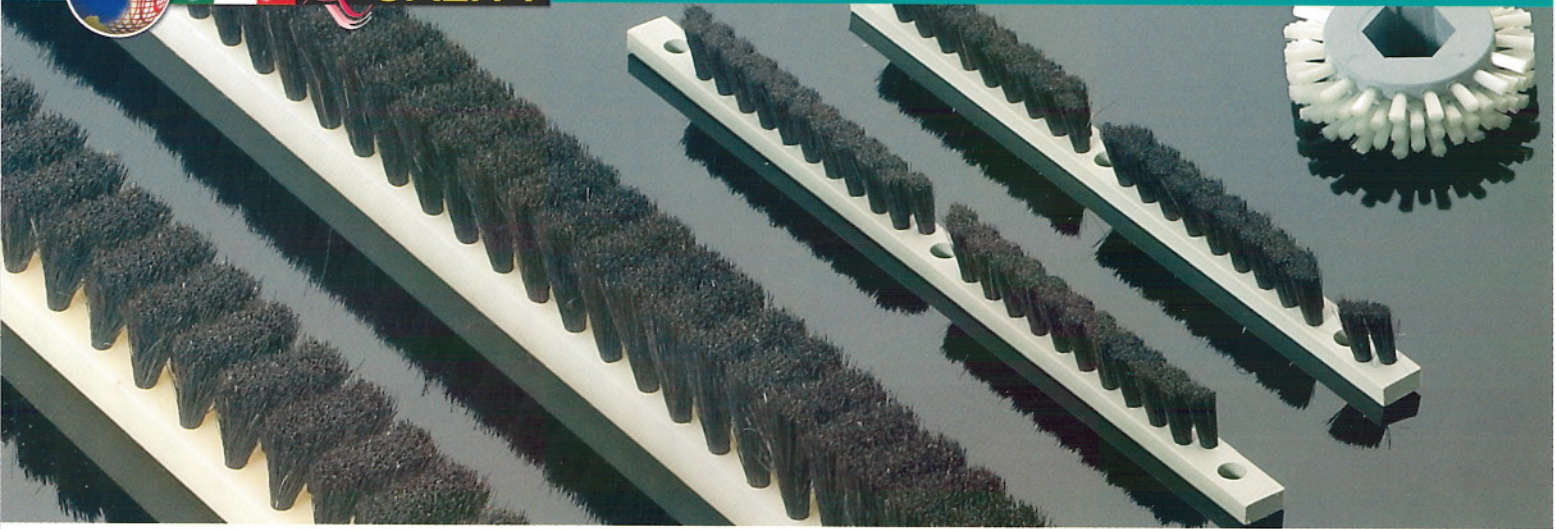

**Original**

155 mm - 6,10"

12 mm - 0,47"

CODICE CODE - CÓDIGO
<b>10300</b>

**Original**

170 mm - 6,69"

12 mm - 0,47"

CODICE CODE - CÓDIGO
<b>10302</b>

**Original**

20 mm - 0,79"

172 mm - 6,77"

15 mm - 0,59"

CODICE CODE - CÓDIGO
<b>10304</b>

**Original**

21 mm - 0,83"

158 mm - 6,22"

22 mm - 0,87"

CODICE CODE - CÓDIGO
<b>10306</b>

**Original**

21 mm - 0,83"

172 mm - 6,77"

30 mm - 1,18"

CODICE CODE - CÓDIGO
<b>10308</b>

**Original**

19 mm - 0,75"

245 mm - 9,65"

12 mm - 0,47"

CODICE CODE - CÓDIGO
<b>10310</b>

È vietata la riproduzione di ogni singola o parziale fotografia del presente catalogo, tutti i diritti sono riservati. - Any reproduction in whole or in part of this catalogue, is strictly prohibited. All rights reserved. - Se prohibe terminantemente la reproducción total o parcial de cada fotografía contenida en este catálogo. Todos los derechos están reservados. ممنوع الأستساخ من كل أو بعض هذا الدليل منعاً باتاً. كل الحقوق محفوظة.



**Original**

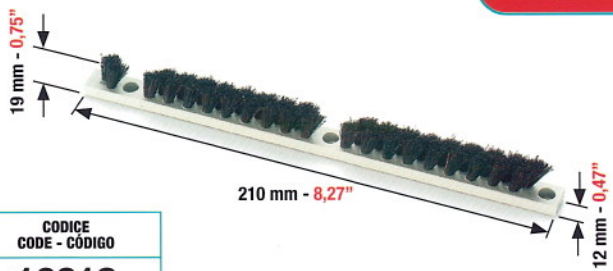

CODICE  
CODE - CÓDIGO

**10312**

**Original**

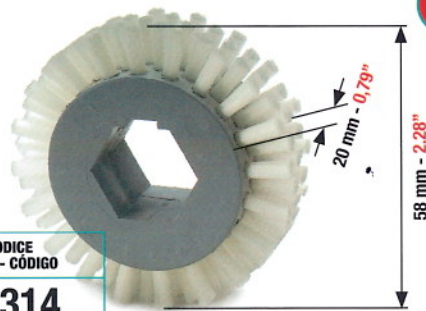

CODICE  
CODE - CÓDIGO

**10314**

**Original**

PELO RADO  
THIN  
PELO POCO DENSO



CODICE  
CODE - CÓDIGO

**10315**

**Original**

PELO RADO  
THIN  
PELO POCO DENSO



CODICE  
CODE - CÓDIGO

**10316**

**Original**

PELO FOLTO  
THICK  
PELO TUPIDO



CODICE  
CODE - CÓDIGO

**10318**

**Original**



CODICE  
CODE - CÓDIGO

**10320**

**Original**

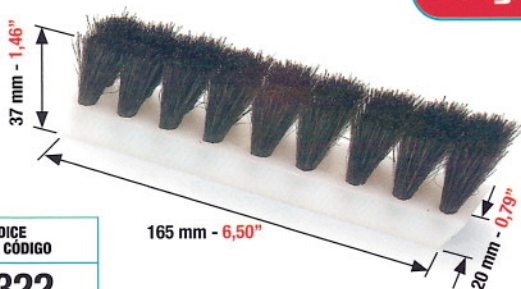

CODICE  
CODE - CÓDIGO

**10322**

**Original**

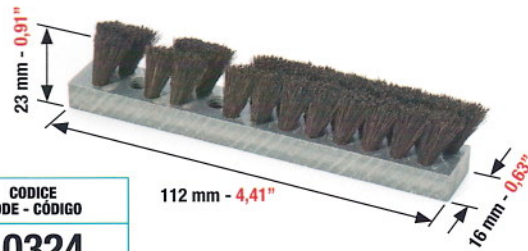

CODICE  
CODE - CÓDIGO

**10324**

**Original**



CODICE  
CODE - CÓDIGO

**10326**

CODICE  
CODE - CÓDIGO

È vietata la riproduzione di ogni singola o parziale fotografia del presente catalogo, tutti i diritti sono riservati. - Any reproduction in whole or in part of this catalogue, is strictly prohibited. All rights reserved. - Se prohíbe terminante-  
mente la reproducción total o parcial de cada fotografía contenida en este catálogo. Todos los derechos están reservados. ممنوع الأستنساخ من كل أو بعض هذا الدليل منعاً باتاً. كل الحقوق محفوظة



**CINGHIE DI TRASPORTO  
FEEDER BELTS  
CORREAS DE TRANSPORTE**

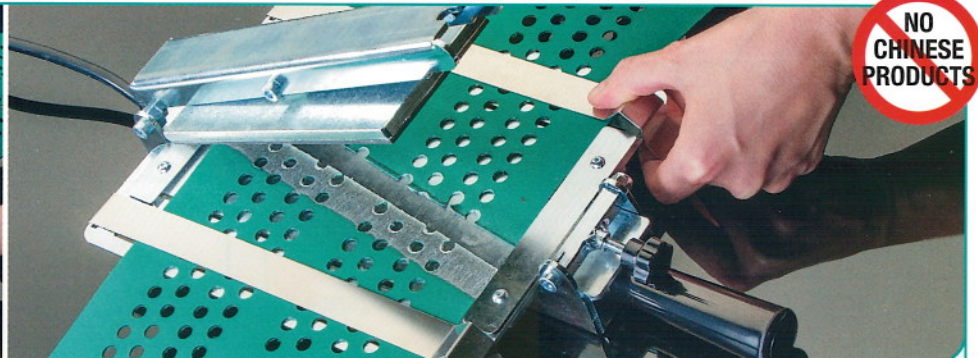

**GRANDE MACCHINA SALDATRICE PER CINGHIE DI TRASPORTO LUCE UTILE mm 230 (cod. 6206)**  
**LARGE WELDING MACHINE FOR FEEDER BELTS MAXIMUM WELDING WIDTH mm 230 (code 6206)**  
**GRANDE MÁQUINA DE SOLDAR PARA CORREAS DE TRANSPORTE MAXIMO UTIL mm 230 (código 6206)**

**PRODOTTA INTERAMENTE IN ITALIA - PRODUCED ENTIRELY IN ITALY - PRODUCIDA TOTALMENTE EN ITALIA**

CERTIFICATA

CERTIFICATION

CERTIFICADA

CODICE  
CODE - CÓDIGO  
**6206**

LARGHEZZA  
WIDTH - ANCHO  
**mm 230**

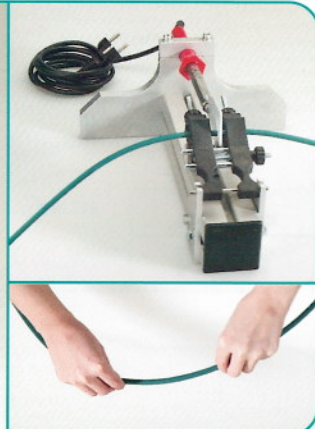

**MACCHINA SALDATRICE PER CINGHIE DI TRASPORTO TONDE**  
**WELDING MACHINE FOR ROUND FEEDER BELTS**  
**MÁQUINA DE SOLDAR PARA CORREAS DE TRANSPORTE REDONDAS**

**PRODOTTA INTERAMENTE IN ITALIA - PRODUCED ENTIRELY IN ITALY - PRODUCIDA TOTALMENTE EN ITALIA**

CERTIFICATA  
CERTIFICATION  
CERTIFICADA

CODICE  
CODE - CÓDIGO  
**6207**



**Original**



**COLLA "SPECIALE" AD ALTA RESISTENZA PER CINGHIE DI TRASPORTO**  
**"SPECIAL" HIGH-RESISTANCE GLUE FOR FEEDER BELTS**  
**COLA "ESPECIAL" DE ALTA RESISTENCIA PARA CORREAS DE TRANSPORTE**

**FIXOL  
FLACONE DA 40 ML - 40 ML BOTTLE - FRASCO DE 40 ML**

CODICE  
CODE - CÓDIGO  
**6201**

È vietata la riproduzione di ogni singola o parziale fotografia del presente catalogo, tutti i diritti sono riservati. - Any reproduction in whole or in part of this catalogue, is strictly prohibited. All rights reserved. - Se prohíbe terminantemente la reproducción total o parcial de cada fotografía contenida en este catálogo. Todos los derechos están reservados. ممنوع الاستسماخ من كل أو بعض هذا الدليل منعاً باتاً. كل الحقوق محفوظة



"S"



28 mm - 1,10"

AC - CB

1302 mm x 28 mm  
51,26" x 1,10"

CINGHIA DI TRASPORTO PER METTIFOGLIO PER:  
FEEDER BELT FOR:  
CORREA DE TRANSPORTE PARA:

**ROLAND FAVORIT-OB**

CODICE  
CODE - CÓDIGO

**6040**

"S"



28 mm - 1,10"

AC - CB

1912 mm x 28 mm  
75,28" x 1,10"

CINGHIA DI TRASPORTO PER METTIFOGLIO PER:  
FEEDER BELT FOR:  
CORREA DE TRANSPORTE PARA:

**ROLAND REKORD RZK3B/600**

TUTTI I MODELLI - ALL MODELS - TODOS LOS MODELOS

CODICE  
CODE - CÓDIGO

**6055**

"S"

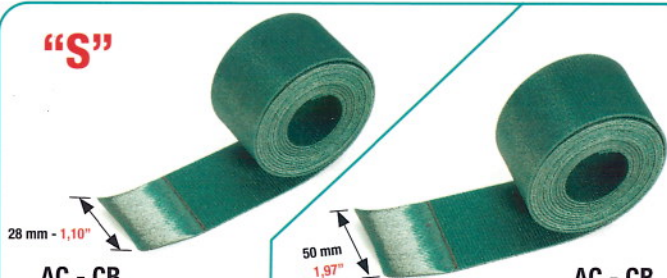

28 mm - 1,10"

AC - CB

2022 mm x 28 mm  
79,61" x 1,10"

**6062**

50 mm  
1,97"

AC - CB

**6062-A**

2022 mm x 50 mm  
79,61" x 1,97"

CINGHIA DI TRASPORTO PER METTIFOGLIO PER:  
FEEDER BELT FOR:  
CORREA DE TRANSPORTE PARA:

**ROLAND 800**

TUTTI I MODELLI - ALL MODELS - TODOS LOS MODELOS

CODICE  
CODE - CÓDIGO

**6062**

**6062-A**

**OLD MODEL**

"T"

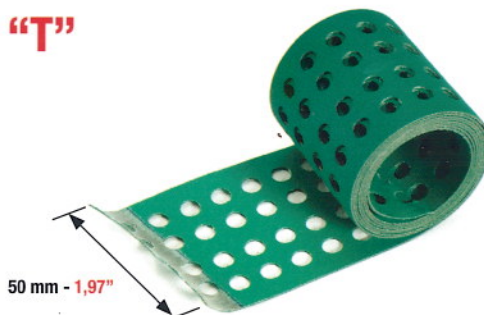

50 mm - 1,97"

AC - CB

COD. 6050

1045 mm x 50 mm  
41,14" x 1,97"

AC - CB

COD. 6051

1815 mm x 50 mm  
71,46" x 1,97"

CINGHIA DI TRASPORTO PERFORATA PER METTIFOGLIO PER:  
PERFORATED FEEDER BELT FOR:  
CORREA DE TRANSPORTE PERFORADA PARA:

**ROLAND 300 STANDARD (COD. 6050)**

**ROLAND 300 SPECIAL (COD. 6051)**

CODICE  
CODE - CÓDIGO

**6050**

**6051**

"T"

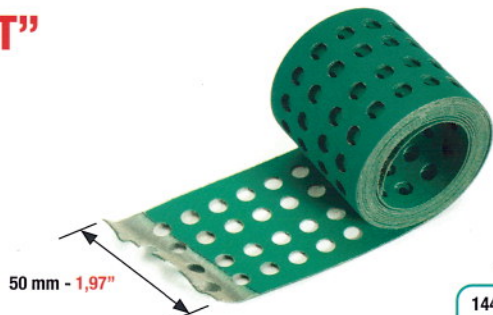

50 mm - 1,97"

AC - CB

1440 mm x 50 mm  
56,69" x 1,97"

CINGHIA DI TRASPORTO PERFORATA PER METTIFOGLIO PER:  
PERFORATED FEEDER BELT FOR:  
CORREA DE TRANSPORTE PERFORADA PARA:

**ROLAND 200**

CODICE  
CODE - CÓDIGO

**6045**

"T"

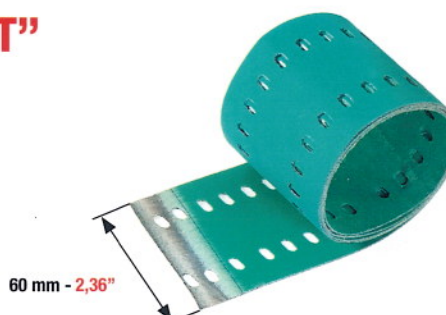

60 mm - 2,36"

AC - CB

830 mm x 60 mm  
32,68" x 2,36"

CINGHIA DI TRASPORTO PERFORATA PER METTIFOGLIO PER:  
PERFORATED FEEDER BELT FOR:  
CORREA DE TRANSPORTE PERFORADA PARA:

**ROLAND PRAKTIKA-00**

CODICE  
CODE - CÓDIGO

**6043**



**"T"**



70 mm - 2.76"

AC - CB

1780 mm x 70 mm  
70.08" x 2.76"

CINGHIA DI TRASPORTO PERFORATA PER METTIFOGLIO PER:  
PERFORATED FEEDER BELT FOR:  
CORREA DE TRANSPORTE PERFORADA PARA:

**ROLAND 500 - ALL MODELS**

	CODICE CODE - CÓDIGO
	<b>6063-A</b>

**"T"**



80 mm - 3.15"

AC - CB

1410 mm x 80 mm  
55.51" x 3.15"

CINGHIA DI TRASPORTO PERFORATA PER METTIFOGLIO PER:  
PERFORATED FEEDER BELT FOR:  
CORREA DE TRANSPORTE PERFORADA PARA:

**ROLAND REKORD RZK3B/600**

	CODICE CODE - CÓDIGO
	<b>6061</b>

**"T"**



80 mm - 3.15"

AC - CB

2930 mm x 80 mm  
115.35" x 3.15"

CINGHIA DI TRASPORTO PERFORATA PER METTIFOGLIO PER:  
PERFORATED FEEDER BELT FOR:  
CORREA DE TRANSPORTE PERFORADA PARA:

**ROLAND 700**  
TUTTI I MODELLI - ALL MODELS - TODOS LOS MODELOS

	CODICE CODE - CÓDIGO
	<b>6060</b>

**"T"**



150 mm - 5.91"

AC - CB

2850 x 150 mm  
112.20" x 5.91"

CINGHIA DI TRASPORTO PERFORATA PER METTIFOGLIO PER:  
PERFORATED FEEDER BELT FOR:  
CORREA DE TRANSPORTE PERFORADA PARA:

**ROLAND 900 - ALL MODELS**

	CODICE CODE - CÓDIGO
	<b>6063</b>

**"S"**



AC - CB

**6104** 460 mm x 12 mm  
18,11" x 0,47"

**6104-A** 490 mm x 12 mm  
19,29" x 0,47"

CINGHIA SPECIALE PER DISPOSITIVO ANTISCARTINO:  
SPECIAL BELT FOR ANTI SET-OFF SYSTEM:  
CORREA ESPECIAL PARA DISPOSITIVO DE POLVOS ANTIMACULADORES:

**WEKO**

	CODICE CODE - CÓDIGO
	<b>6104</b>
	<b>6104-A</b>

Empty product information box.





**RUOTE DI TRASPORTO PER SEZIONE METTIFOGLIO**  
**FEEDER WHEELS**  
**RUEDAS DE TRANSPORTE PARA MARCADOR**

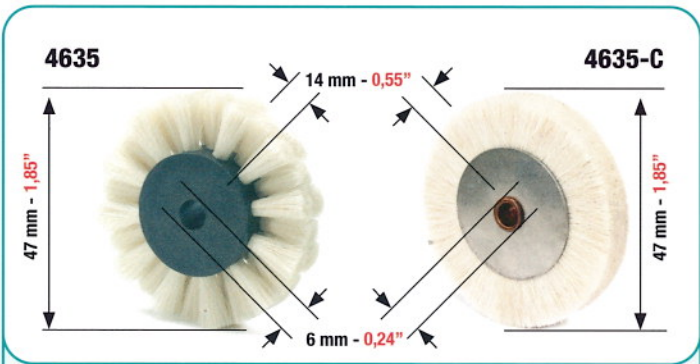

**RUOTA BIANCA A SPAZZOLA PER CARTA PER:**  
**WHITE BRUSH WHEEL FOR PAPER FOR:**  
**RUEDA DE CEPILLO BLANCO PARA PAPEL PARA:**

**KOMORI**  
**TUTTI I MODELLI - ALL MODELS - TODOS LOS MODELOS**

ORDINE MINIMO 2 PZ / CODICE MINIMUM ORDER 2 PCS / CODE PEDIDO MÍNIMO 2 PZ / CÓDIGO	CODICE CODE - CÓDIGO	CODICE CODE - CÓDIGO
	<b>4635</b>	<b>4635-C</b>

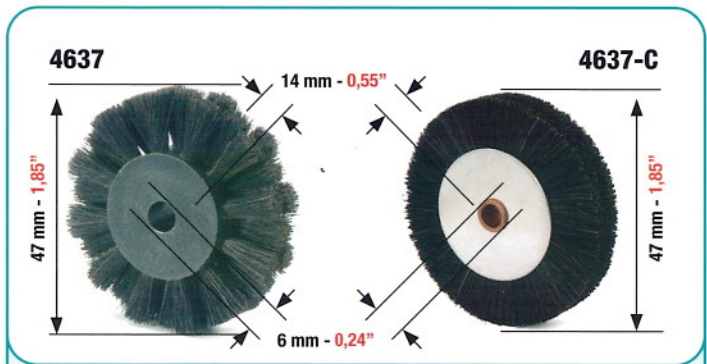

**RUOTA NERA A SPAZZOLA PER CARTONE PER:**  
**BLACK BRUSH WHEEL FOR CARDBOARD FOR:**  
**RUEDA DE CEPILLO NEGRO PARA CARTÓN PARA:**

**KOMORI**  
**TUTTI I MODELLI - ALL MODELS - TODOS LOS MODELOS**

ORDINE MINIMO 2 PZ / CODICE MINIMUM ORDER 2 PCS / CODE PEDIDO MÍNIMO 2 PZ / CÓDIGO	CODICE CODE - CÓDIGO	CODICE CODE - CÓDIGO
	<b>4637</b>	<b>4637-C</b>

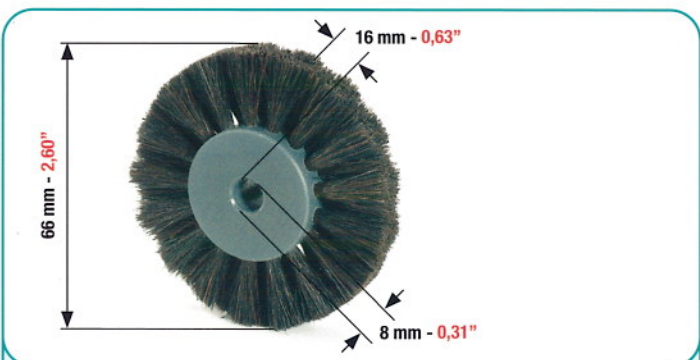

**RUOTA DI TRASPORTO A SPAZZOLA PER SEZIONI METTIFOGGIO PER:**  
**BRUSH WHEEL FOR FEEDER SECTION FOR:**  
**RUEDA DE TRANSPORTE DE CEPILLO PARA INTRODUCOR DE PAPEL PARA:**

**MIEHLE - M.A.N. - ROLAND**

ORDINE MINIMO 2 PEZZI MINIMUM ORDER 2 PCS PEDIDO MÍNIMO 2 PIEZAS	CODICE CODE - CÓDIGO	
	<b>4679</b>	

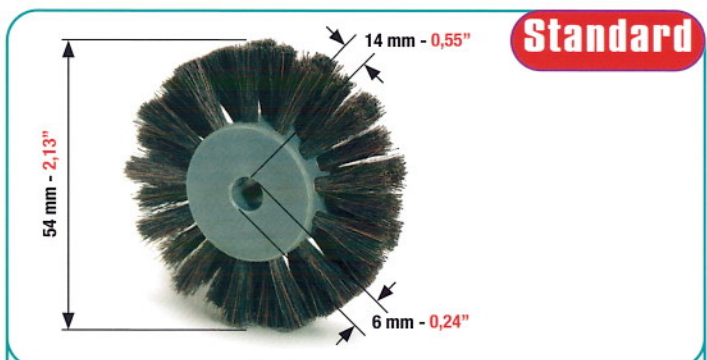

**RUOTA DI TRASPORTO A SPAZZOLA PER:**  
**BRUSH WHEEL FOR:**  
**RUEDA DE CEPILLO PARA:**

**MABEG**

ORDINE MINIMO 2 PEZZI MINIMUM ORDER 2 PCS PEDIDO MÍNIMO 2 PIEZAS	CODICE CODE - CÓDIGO	
	<b>4675</b>	



**Standard**

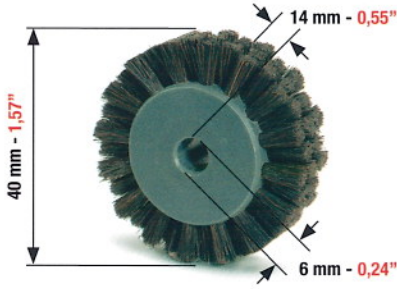

**RUOTA DI TRASPORTO A SPAZZOLA PER:  
BRUSH WHEEL FOR:  
RUEDA DE CEPILLO PARA:**

**MABEG**

ORDINE MINIMO 2 PEZZI  
MINIMUM ORDER 2 PCS  
PEDIDO MÍNIMO 2 PIEZAS

CODICE  
CODE - CÓDIGO  
**4676**

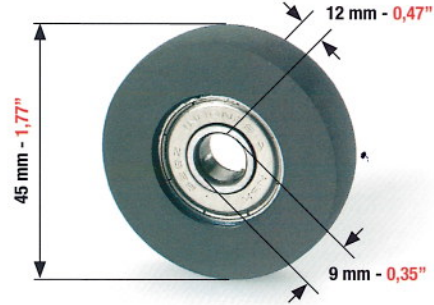

**RUOTA DI TRASPORTO IN GOMMA PER:  
RUBBER WHEEL FOR FEEDER FOR:  
RUEDA DE TRANSPORTE EN GOMA PARA:**

**ROLAND - MABEG**

CODICE  
CODE - CÓDIGO  
**4661**

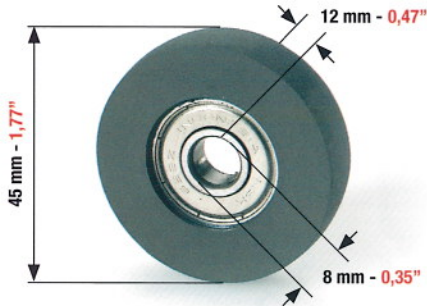

**RUOTA DI TRASPORTO IN GOMMA PER:  
RUBBER WHEEL FOR FEEDER FOR:  
RUEDA DE TRANSPORTE EN GOMA PARA:**

CODICE  
CODE - CÓDIGO  
**4661-A**

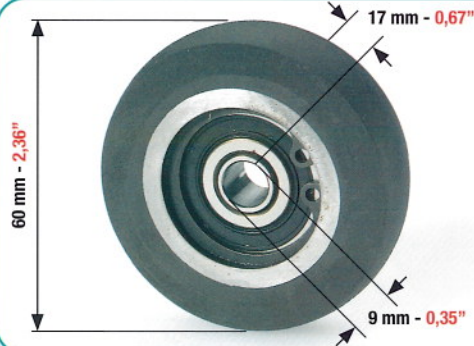

**RUOTA DI TRASPORTO IN GOMMA COMPLETA DI CUSCINETTO PER:  
RUBBER WHEEL COMPLETE WITH BEARING FOR:  
RUEDA DE TRANSPORTE EN GOMA CON RODAMIENTO PARA:**

**ROLAND 300/500/700/900**

**TUTTI I MODELLI - ALL MODELS - TODOS LOS MODELOS**

CODICE  
CODE - CÓDIGO  
**4665**

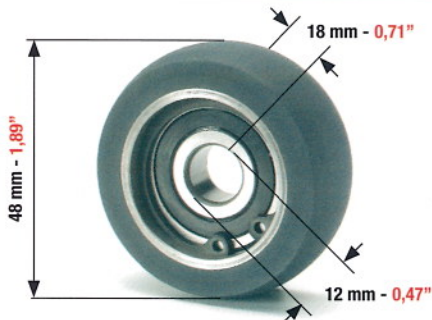

**RUOTA DI TRASPORTO IN GOMMA COMPLETA DI CUSCINETTO PER:  
RUBBER WHEEL COMPLETE WITH BEARING FOR:  
RUEDA DE TRANSPORTE EN GOMA CON RODAMIENTO PARA:**

**ROLAND**

CODICE  
CODE - CÓDIGO  
**4644**

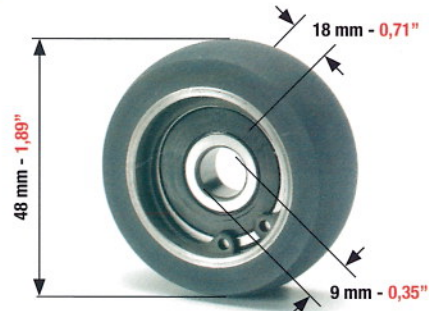

**RUOTA DI TRASPORTO IN GOMMA COMPLETA DI CUSCINETTO PER:  
RUBBER WHEEL COMPLETE WITH BEARING FOR:  
RUEDA DE TRANSPORTE EN GOMA CON RODAMIENTO PARA:**

**ROLAND - MABEG**

CODICE  
CODE - CÓDIGO  
**4644-A**



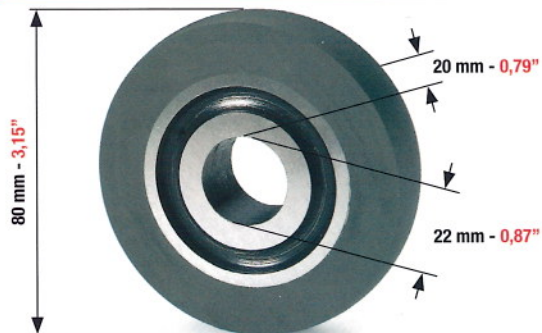

**RUOTA DI TRASPORTO IN GOMMA**  
**RUBBER WHEEL FOR FEEDER**  
**RUEDA DE TRANSPORTE EN GOMA**

ORDINE MINIMO 2 PEZZI  
 MINIMUM ORDER 2 PCS  
 PEDIDO MÍNIMO 2 PIEZAS

CODICE  
 CODE - CÓDIGO

**4668**

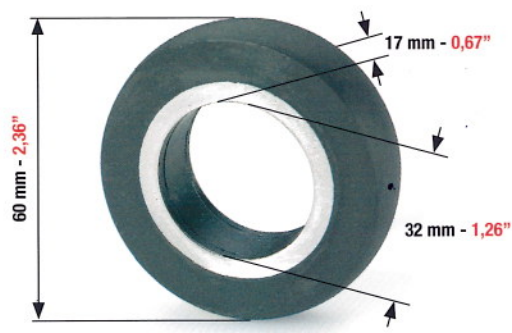

**RUOTA DI TRASPORTO IN GOMMA PER:**  
**RUBBER WHEEL FOR FEEDER FOR:**  
**RUEDA DE TRANSPORTE EN GOMA PARA:**

ORDINE MINIMO 2 PEZZI  
 MINIMUM ORDER 2 PCS  
 PEDIDO MÍNIMO 2 PIEZAS

CODICE  
 CODE - CÓDIGO

**4662**

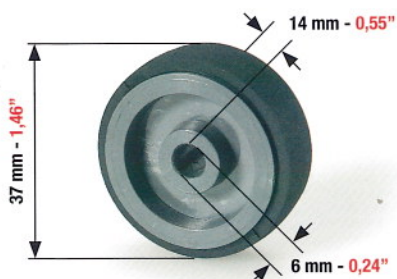

**RUOTA DI TRASPORTO IN PLASTICA E GOMMA PER:**  
**FEEDER WHEEL IN PLASTIC AND RUBBER FOR:**  
**RUEDA DE TRANSPORTE DE PLÁSTICO Y GOMA PARA:**

**MABEG**

ORDINE MINIMO 2 PEZZI  
 MINIMUM ORDER 2 PCS  
 PEDIDO MÍNIMO 2 PIEZAS

CODICE  
 CODE - CÓDIGO

**4622**

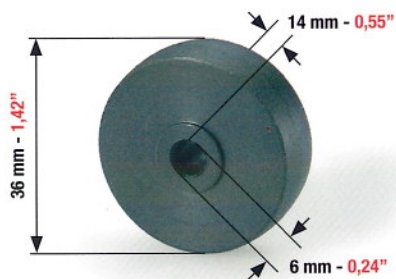

**RUOTA DI TRASPORTO IN PLASTICA PER:**  
**FEEDER WHEEL IN PLASTIC FOR:**  
**RUEDA DE TRANSPORTE DE PLÁSTICO PARA:**

**MABEG**

ORDINE MINIMO 2 PEZZI  
 MINIMUM ORDER 2 PCS  
 PEDIDO MÍNIMO 2 PIEZAS

CODICE  
 CODE - CÓDIGO

**4623**

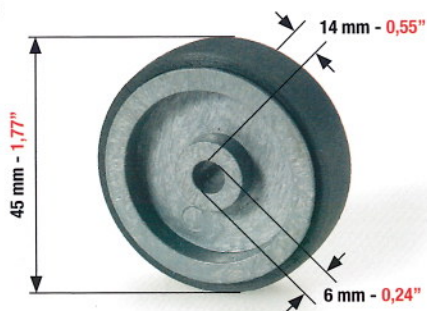

**RUOTA DI TRASPORTO IN PLASTICA E GOMMA PER:**  
**FEEDER WHEEL IN PLASTIC AND RUBBER FOR:**  
**RUEDA DE TRANSPORTE DE PLÁSTICO Y GOMA PARA:**

**ROLAND 700**  
**MABEG**

ORDINE MINIMO 2 PEZZI  
 MINIMUM ORDER 2 PCS  
 PEDIDO MÍNIMO 2 PIEZAS

CODICE  
 CODE - CÓDIGO

**4624**

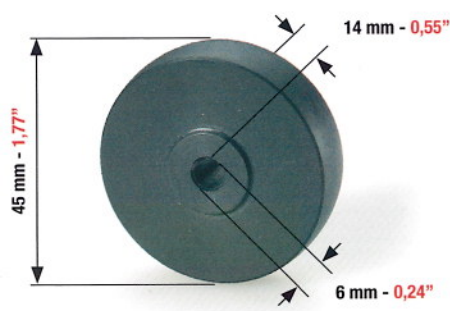

**RUOTA DI TRASPORTO IN PLASTICA PER:**  
**FEEDER WHEEL IN PLASTIC FOR:**  
**RUEDA DE TRANSPORTE DE PLÁSTICO PARA:**

**ROLAND 700**  
**MABEG**

ORDINE MINIMO 2 PEZZI  
 MINIMUM ORDER 2 PCS  
 PEDIDO MÍNIMO 2 PIEZAS

CODICE  
 CODE - CÓDIGO

**4625**



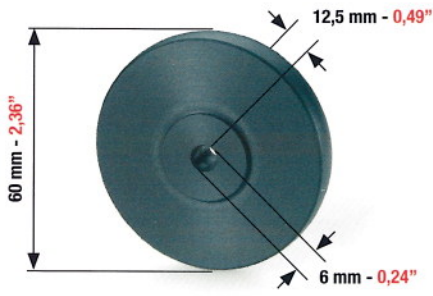

**RUOTA DI TRASPORTO IN PLASTICA PER:  
FEEDER WHEEL IN PLASTIC FOR:  
RUEDA DE TRANSPORTE DE PLÁSTICO PARA:**

**MABEG**

ORDINE MINIMO 2 PEZZI  
MINIMUM ORDER 2 PCS  
PEDIDO MÍNIMO 2 PIEZAS

CODICE  
CODE - CÓDIGO

**4627**

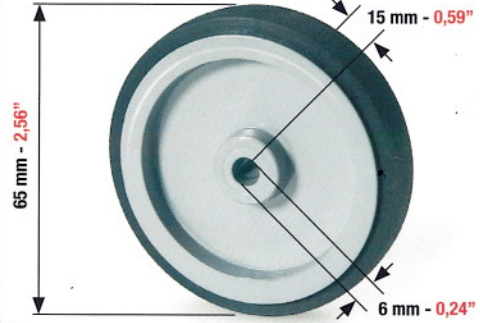

**RUOTA DI TRASPORTO IN PLASTICA E GOMMA PER:  
FEEDER WHEEL IN PLASTIC AND RUBBER FOR:  
RUEDA DE TRANSPORTE DE PLÁSTICO Y GOMA PARA:**

**ROLAND ULTRA  
MABEG**

ORDINE MINIMO 2 PEZZI  
MINIMUM ORDER 2 PCS  
PEDIDO MÍNIMO 2 PIEZAS

CODICE  
CODE - CÓDIGO

**4628**

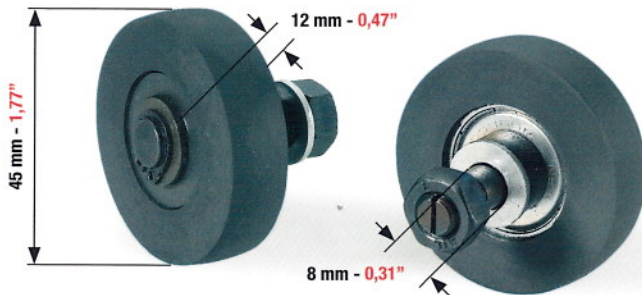

**RUOTA DI TRASPORTO IN GOMMA COMPLETA DI PERNO PER:  
COMPLETE FEEDER WHEEL IN RUBBER FOR:  
RUEDA DE TRANSPORTE DE GOMA COMPLETA PARA:**

**MABEG**

CODICE  
CODE - CÓDIGO

**4671**



# TECHNO FILTER PLUS

**FILTRI DI RICIRCOLO  
RECIRCULATION FILTERS  
FILTROS PARA RECIRCULADORES**

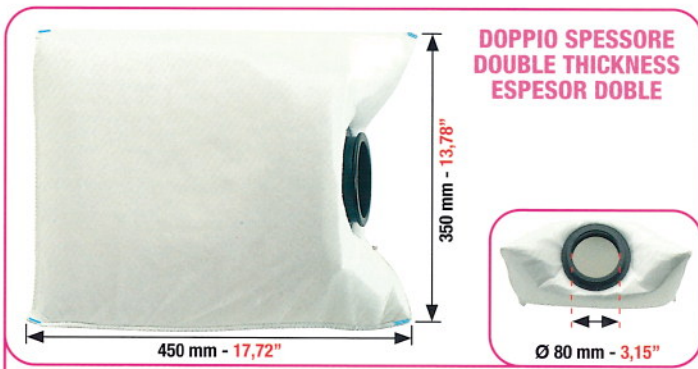

**TECHNOTRANS**

**FOR ALL SHEETFED MACHINES**

CODICE CODE - CÓDIGO	
<b>10000</b>	

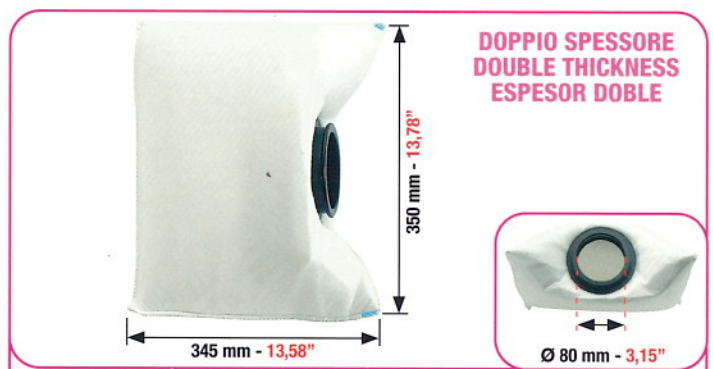

**TECHNOTRANS**

**FOR ALL SHEETFED MACHINES**

ORDINE MINIMO 2 PEZZI MINIMUM ORDER 2 PCS PEDIDO MINIMO 2 PIEZAS	CODICE CODE - CÓDIGO	
	<b>10001</b>	

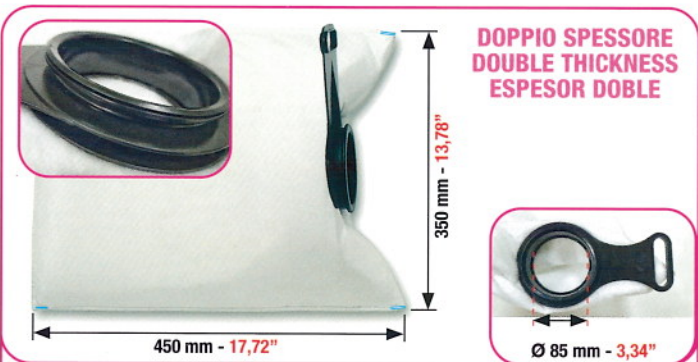

**TECHNOTRANS**

**SIMILAR CODE OEM 137275082**

**FOR ALL SHEETFED MACHINES**

ORDINE MINIMO 2 PEZZI MINIMUM ORDER 2 PCS PEDIDO MINIMO 2 PIEZAS	CODICE CODE - CÓDIGO
	<b>10040</b>

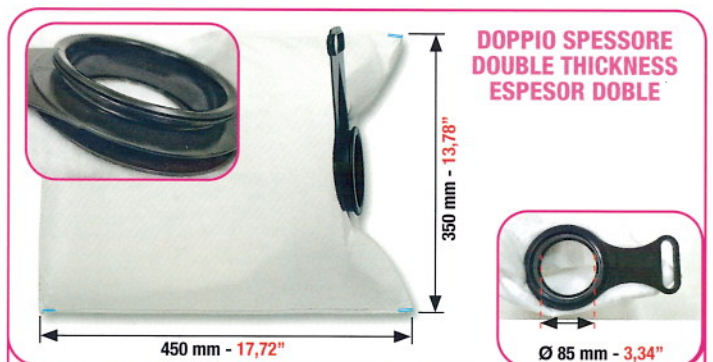

**TECHNOTRANS - ALL WEB MACHINES**

**SIMILAR CODE OEM 137275083 - 137275082**

**FOR ALL WEB MACHINES**

ORDINE MINIMO 2 PEZZI MINIMUM ORDER 2 PCS PEDIDO MINIMO 2 PIEZAS	CODICE CODE - CÓDIGO
	<b>10040-B/WEB</b>

È vietata la riproduzione di ogni singola o parziale fotografia del presente catalogo, tutti i diritti sono riservati. - Any reproduction in whole or in part of this catalogue, is strictly prohibited. All rights reserved. - Se prohíbe terminantemente la reproducción total o parcial de cada fotografía contenida en este catálogo. Todos los derechos están reservados. ممنوع الاستساح من كل أو بعض هذا الدليل منعاً باتاً. كل الحقوق محفوظة



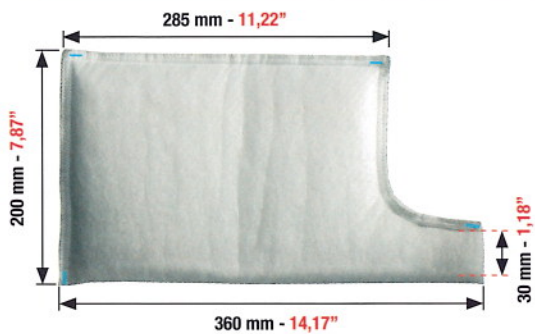

## TECHNOTRANS

**ROLAND 200/300**

ORDINE MINIMO 2 PEZZI  
MINIMUM ORDER 2 PCS  
PEDIDO MINIMO 2 PIEZAS

CODICE  
CODE - CÓDIGO

**10049**



## TECHNOTRANS

**LITHOMAN IV**

ORDINE MINIMO 2 PEZZI  
MINIMUM ORDER 2 PCS  
PEDIDO MINIMO 2 PIEZAS

CODICE  
CODE - CÓDIGO

**10081**

**NOVITÀ - NEW - NUEVO . NOVITÀ - NEW - NUEVO . NOVITÀ - NEW - NUEVO**

## RECIRCULATION FILTER BETA-F TECHNOTRANS



SET COMPLETO  
COMPLETE SET  
JUEGO COMPLETO

CODICE - CODE - CÓDIGO

**10098-A**

## CAPS FOR NEW BETA-F SYSTEMS



BOX DA 7 PEZZI  
BOX OF 7 PCS  
BOX DE 7 PIEZAS

CODICE - CODE - CÓDIGO

**10099**

# TECHNO-OIL-FILTER



**FatVampire<sup>®</sup>**  
SORB

PULIZIA E SICUREZZA - CLEANLINESS AND SAFETY  
LIMPIEZA Y SEGURIDAD

ORDINE MINIMO 4 PEZZI  
MINIMUM ORDER 4 PCS  
PEDIDO MINIMO 4 PIEZAS

CODICE - CODE - CÓDIGO

**10048**



# TECHNO liquid FILTER

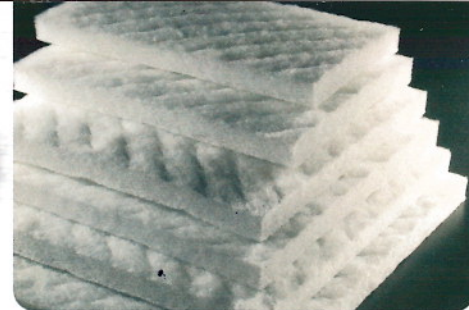

## SPECIALE TESSUTO DI FILTRAGGIO PER VASCHE DI RIFLUSSO DEGLI IMPIANTI DI BAGNATURA SPECIAL FILTERING NET FOR WATER RESERVOIRS OF FOUNTAIN RECIRCULATING SYSTEMS TEJIDO FILTRANTE ESPECIAL PARA TANQUES DE REFLUJO DE SISTEMAS DE MOJADO

 **TECHNO LIQUID FILTER**  
"HIGH FILTRATION" è uno speciale materassino per filtraggio, addensato termicamente da un lato, appositamente realizzato per le vasche di riflusso degli impianti di bagnatura per la depurazione dell'acqua.

 **TECHNO LIQUID FILTER**  
"HIGH FILTRATION" is a special filter mat composed of thermally compressed fleece layers, specially developed for the water reservoirs of fountain recirculating systems.

 **TECHNO LIQUID FILTER**  
"HIGH FILTRATION" es una colchoneta filtradora especial, condensada térmicamente de un lado, expresamente realizada para el tanque de reflujo del sistema de mojado, para la depuración del agua.



### MISURE STANDARD - STANDARD SIZES - TAMAÑOS ESTÁNDAR

COD.	mm
10384	95 x 445
10385	115 x 370
10386	120 x 1060
10387	120 x 440
10388	120 x 480
10390	140 x 380
10411	150 x 320
10400	150 x 340
10410	150 x 460
10547	150 x 810
10553	150 x 1650
10555	160 x 160
10415	160 x 250
10416	160 x 260
10554	160 x 530
10561	165 x 1815
10567	166 x 1827
10417	170 x 170
10421	170 x 260
10418	180 x 180
10420	180 x 280
10425	180 x 480
10542	196 x 436
10429	200 x 270

COD.	mm
10430	200 x 280
10440	200 x 320
10450	200 x 440
10450B	200 x 500
10451	205 x 405
10562	205 x 440
10452	210 x 300
10557	220 x 167
10453	220 x 270
10457	220 x 330
10458	220 x 660
10459	230 x 230
10465	230 x 460
10508	240 x 240
10461	240 x 450
10468	240 x 480
10455	250 x 260
10475	250 x 290
10460	250 x 300
10472	250 x 350
10544	250 x 400
10470	250 x 470
10462	250 x 490
10480	250 x 670

COD.	mm
10471	250 x 750
10556	254 x 305
10558	254 x 380
10511	255 x 675
10563	260 x 360
10489	260 x 475
10495	260 x 500
10483	270 x 310
10491	270 x 320
10492	270 x 470
10493	270 x 490
10486	270 x 780
10484	280 x 360
10487	300 x 400
10481	300 x 460
10481A	300 x 470
10485	300 x 490
10488	300 x 640
10488A	300 x 660
10546	300 x 1000
10490	305 x 1150
10543	310 x 335
10500	315 x 660
10501	315 x 1080

COD.	mm
10502	315 x 1150
10503A	320 x 340
10503B	320 x 470
10534	320 x 390
10504	330 x 1080
10535	350 x 390
10564	350 x 450
10482	350 x 500
10507	360 x 360
10512	360 x 460
10509	360 x 580
10541	365 x 1160
10565	375 x 425
10537	380 x 440
10545	380 x 460
10503	380 x 760
10536	390 x 770
10506	390 x 880
10531	390 x 1140
10505	390 x 1940
10533	400 x 210
10510	400 x 400
10514	400 x 500
10515	400 x 540

COD.	mm
10538	400 x 750
10540	400 x 770
10520	400 x 900
10539	400 x 1156
10525	420 x 480
10566	428 x 625
10527	430 x 430
10528	440 x 600
10529	450 x 1550
10559	457 x 622
10526	460 x 720
10532	500 x 500
10548	500 x 600
10530	500 x 750
10552	550 x 550
10524	550 x 600
10549	600 x 700
10494	625 x 625

PUÒ ESSERE FORNITO IN QUALSIASI MISURA SPECIALE VENGA SPECIFICATAMENTE RICHIESTA  
CAN ALSO BE SUPPLIED IN ANY SPECIAL SIZE REQUIRED / SE PUEDE SUMINISTRAR EN CUALQUIER TAMAÑO ESPECIAL BAJO PEDIDO



# TECHNO Air FILTER

PER SISTEMI D'ARIA / FOR AIR SYSTEMS  
PARA SISTEMAS DE AIRE:  
UTA - GABINE - COMPRESSORS

## MISURE STANDARD - STANDARD SIZES - TAMAÑOS ESTÁNDAR

COD.	mm
10104	160 x 340
10103	200 x 440
10105	210 x 210
10106	235 x 550
10113	250 x 1550
10126	250 x 1700
10119	270 x 780
10108	275 x 750
10109	280 x 800

COD.	mm
10107	285 x 285
10117	300 x 1110
10114	350 x 450
10124	400 x 600
10111	420 x 1100
10110	510 x 1210
10112	520 x 1300
10115	580 x 1440
10116	590 x 455

COD.	mm
10118	590 x 1220
10125	670 x 1470
10130	680 x 1440
10135	700 x 900
10140	720 x 1420
10143	870 x 1300
10152	1020 x 450
10150	1100 x 1300
10151	1440 x 1680



RICHIEDETE IL LISTINO PREZZI DELL'INTERA GAMMA "TECHNO AIR FILTER".  
REQUEST THE PRICE LIST FOR THE FULL RANGE OF "TECHNO AIR FILTER".  
SOLICITE LA LISTA DE PRECIOS PARA LA GAMA COMPLETA DE "TECHNO AIR FILTER".

## OIL FILTERS

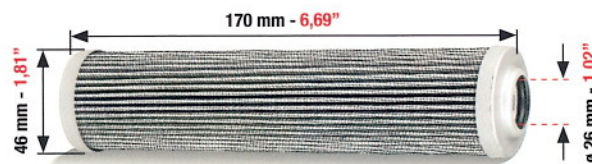

### OIL FILTER FOR ROLAND 700/900

CODICE  
CODE - CÓDIGO

**10405**

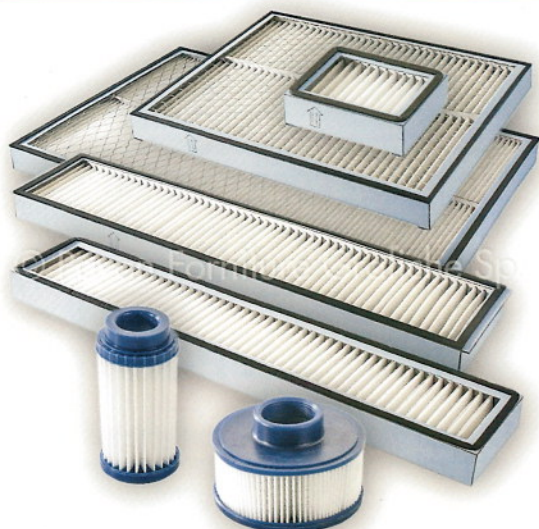

## CATALOGO - CATALOGUE

TROVI TUTTE LE INFORMAZIONI NEL CATALOGO FILTRI!  
YOU CAN FIND ALL THE INFORMATION IN THE FILTERS CATALOGUE!  
¡ENCUENTRA TODA LA INFORMACIÓN EN EL CATÁLOGO DE LOS FILTROS!





## HELP FOR A PERFECT FILTRATION

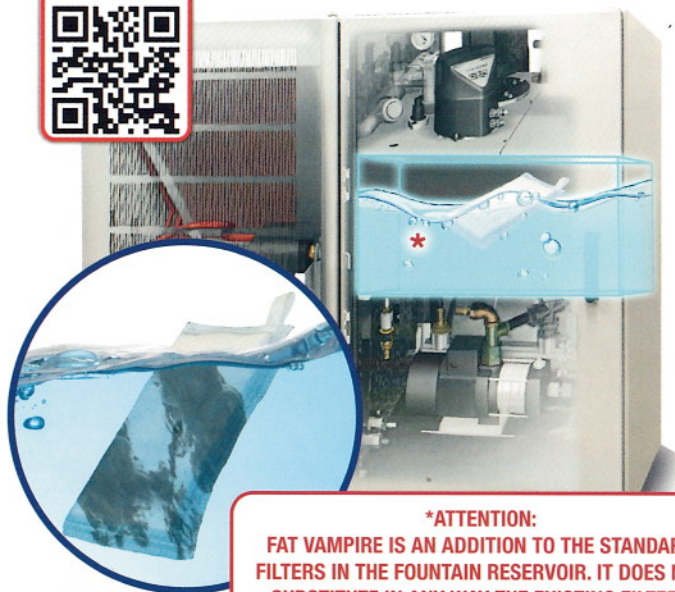

**\*ATTENTION:**  
FAT VAMPIRE IS AN ADDITION TO THE STANDARD FILTERS IN THE FOUNTAIN RESERVOIR. IT DOES NOT SUBSTITUTE IN ANY WAY THE EXISTING FILTERS

**FAT VAMPIRE<sup>®</sup>** is a special filtration pad designed specifically for all fountain solution systems in offset and web offset printing machines.

**FAT VAMPIRE<sup>®</sup>** absorbs all the oily pollution (invisible) present on the surface of the water in the fountain reservoir, which the standard filters are not able to hold completely.

**FAT VAMPIRE<sup>®</sup>** floats and prevents the pollution that has escaped filtration from being transferred to and consequently contaminating all the printing units. It does not substitute the standard filters in the system, it provides the perfect combination that completes the filtration process.

When it is saturated with oil and grease (ink residues), it sinks and must be replaced

## WHY FAT VAMPIRE?

It has always been extremely important to interrupt the flow of pollution (unfiltered residues) which accumulates constantly, day by day, and "invisibly" in each individual printing unit of offset machines printing numerous colours. Over the course of days, months, years, this continuous accumulation can give origin to "unthinkable" problems which have never been resolved (ghosting) and are without explanation even today !



**FAT VAMPIRE:  
THE AID THAT EVERY FOUNTAIN  
SYSTEM SHOULD USE!!**

## THE SECRET FOR PERFECT FOUNTAIN SYSTEM WATER!



COMPLETE WITH LOOP FOR HOOKING!

CODICE - CODE - CODIGO



**10045**

**BAG = 5 PCS**



# SPEED NET

## Transfer Cylinder Nets

-  **Anti-marking net to apply onto transfer cylinders on printing presses to prevent colour build-up.**
-  **Tessuto repellente all'inchiostro da applicare sui cilindri di trasferimento per la prevenzione dell'accumulo di colore.**
-  **Tejido repelente a la tinta para aplicar en cilindros de transferencia para la prevención de la acumulación de tinta.**



### ANTI-MARKING SYSTEMS

- Stretchable, flexible Net
- Ink and water repellent
- Quick installation

### SISTEMI ANTI-MACCHIA



- Tessuto flessibile
- Repellente ad acqua e inchiostro
- Rapida Installazione

### SISTEMA ANTI-REPINTE

- Tela flexible
- Repelente al agua y tinta
- Instalación rápida

CODICE CODE CÓDIGO	ARTICLE	MACHINE SIZE MM/INCHES	FOR USE ON THE MACHINES LISTED BELOW
2721896	SPEED 1	36 x 52/23"	GTO 52/SM 52 AND OTHER SMALL OFFSET PRESSES
2721897	SPEED 2	48 x 65/26"	MO 65
2721898	SPEED 3	52 x 72 / 54 x 74 28"/29"	SM 72/SM 74/ROLAND OB/ ROLAND 200 E AND OTHERS
2721899	SPEED 4	64 x 91,5/36"	SORD/RYOBI 920 SERIES
2721900	SPEED 5	72 x 102/40"	SM 102/ROLAND 3B/ROLAND 600/ ROLAND 700 AND OTHERS
2721900A	SPEED 5/6	82 x 113/44"	ROLAND ULTRA/ NEBIOLO AND OTHERS
2721901	SPEED 6	90 x 132/50"	ROLAND ULTRA/ NEBIOLO AND OTHERS
2721902	SPEED 7	100 x 140/56"	ROLAND 800/ ROLAND ULTRA AND OTHERS
2721903	SPEED 8	120 x 160/63"	ROLAND M.A.N./ PLANETA/ NEBIOLO AND OTHERS
2721904	SPEED 9	129 x 185/72"	
2721905	SPEED 10	149 x 205/80"	
2721893	ADHESIVE VELCRO (HOOK)	ROLLS OF 25 METRES	
2721894	NON-ADHESIVE VELCRO (LOOP)	ROLLS OF 25 METRES	

## IMPRESSION CYLINDER JACKETS

-  **CERAMIC TREATED IMPRESSION CYLINDER JACKETS**
-  **CAMICIE PER CILINDRI DI PRESSIONE TRATTATE IN CERAMICA**
-  **GAMISAS CON TRATAMIENTO CERAMICO PARA CILINDROS DE PRESION**

CODICE CODE CÓDIGO	PRESS MODEL	THICKNESS IN MM	BASE DIM (L X W)	OEM PART NUMBER
	MANROLAND			
11355	700	0,301 - 0,305		



# DIE CUTTING JACKETS

## STEEL - ACCIAIO - ACERO

CODICE CODE CÓDIGO	PRESS MODEL	THICKNESS IN MM	MACHINE SIZE
<b>MANROLAND</b>			
4190	PRAKTICA - 00 (UP TO MATR.134-OLD MODEL)	0,30	36 x 52
4195	PRAKTICA - 00 (FROM MATR.134-NEW MODEL)	0,30	36 x 52
4200**	PRAKTICA - 00 (FROM MATR.134-NEW MODEL)	0,30	36 x 52
4205*	PRAKTICA - 00 (FROM MATR.134-NEW MODEL)	0,50	36 x 52
4210	PRAKTICA - 00 (2 COLOURS/45° FOLDED)	0,30	36 x 52
4215	PRAKTICA - 01 (UP TO MATR.173-OLD MODEL)	0,30	48 x 66
4220	PRAKTICA - 01 (FROM MATR.173-NEW MODEL)	0,30	48 x 66
4222	ROLAND 300	0,30	52 x 74
4223	ROLAND REKORD / ROLAND 600	0,30	72 x 103
4225	ROLAND FAVORIT - RFOB	0,30	52 x 72
4226	ROLAND 700	0,30	74 x 104
	**BRASS *PLASTIC		

## UNIVERSAL PRODUCT

PERFECTING WASH

SPEED FILM WASH

(SCHWEGO DAMP 8174)

COD. 27.20926

Special cleaner for anti-marking materials.

**1 BOX = 12 BOTTLES OF 1 LT. EACH**

 Il primo "esclusivo" prodotto di lavaggio universale per la pulizia di tutte le camicie con superficie trattata montate sui cilindri di pressione e di trasferimento.

 The first "exclusive" universal wash product for the cleaning of all cylinder jackets with a treated surface used on the impression and transfer cylinders.

 El primer y "exclusivo" producto de lavado universal para la limpieza de todas las camisas con tratamiento para cilindros de presion y de transferencia.



PER MAGGIORI INFORMAZIONI, CONSULTATE IL CATALOGO "CYLINDER JACKET PLANET®"  
FOR FURTHER DETAILS, PLEASE REQUEST OUR CATALOGUE "CYLINDER JACKET PLANET®"  
PARA OBTENER UNA MAYOR INFORMACION, CONSULTE NUESTRO CATALOGO  
"CYLINDER JACKET PLANET®"



# **SPEED** FILM **BLUE**<sup>®</sup> **STANDARD**

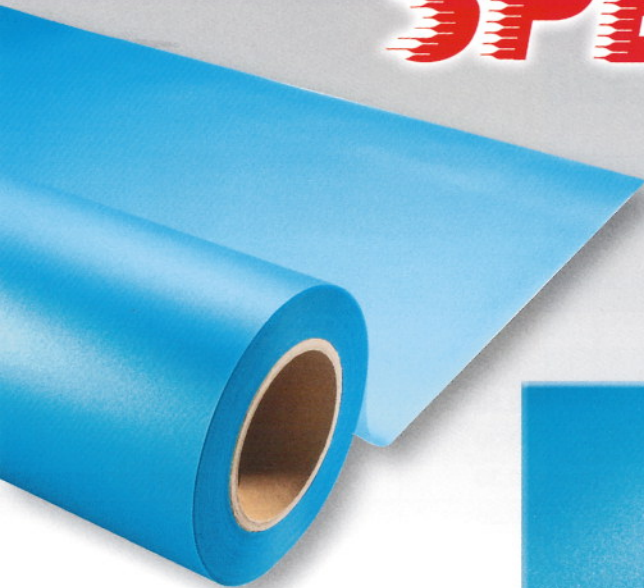

**SPEED FILM BLUE STANDARD**  
può essere fornito  
tagliato in fogli (in qualsiasi misura  
in formato) o in rotoli

**SPEED FILM BLUE STANDARD**  
can be supplied either  
in formatted sheets  
(in any size) or in rolls

**SPEED FILM BLUE STANDARD**  
se puede suministrar  
cortado en formatos  
(de cualquier medida)  
o en rollos

# **SPEED** FILM **BLUE**<sup>®</sup> **PLUS**

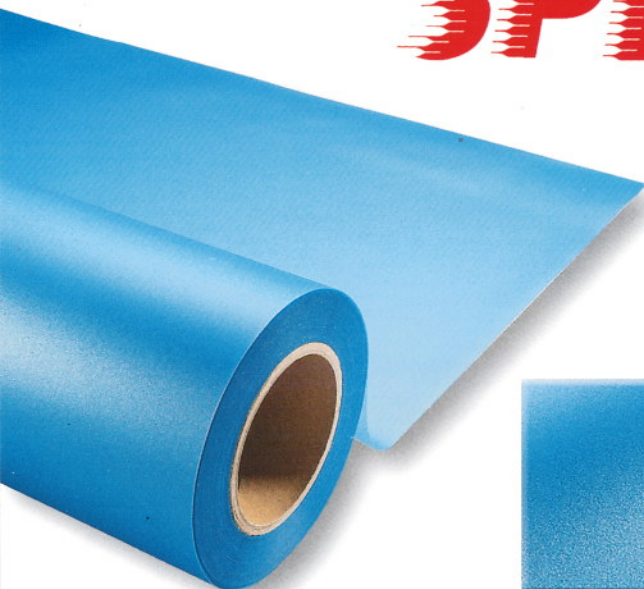

**SPEED FILM BLUE PLUS**  
può essere fornito  
tagliato in fogli (in qualsiasi misura  
in formato) o in rotoli

**SPEED FILM BLUE PLUS**  
can be supplied either  
in formatted sheets  
(in any size) or in rolls

**SPEED FILM BLUE PLUS**  
se puede suministrar  
cortado en formatos  
(de cualquier medida)  
o en rollos

# **SPEED** PAPER<sup>®</sup>



**SPEED PAPER/CARTA**  
può essere fornito  
tagliato in fogli  
(in qualsiasi misura  
in formato) o in rotoli

**SPEED PAPER**  
can be supplied either  
in formatted sheets  
(in any size) or in rolls

**SPEED PAPER/PAPEL**  
se puede suministrar  
cortado en formatos  
(de cualquier medida)  
o en rollos



ADESIVO / ADHESIVE / ADHESIVO

NON ADESIVO / NON-ADHESIVE / NO ADHESIVO

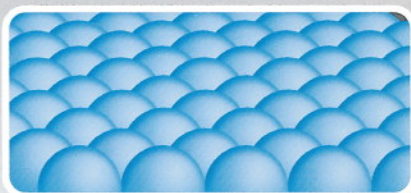

Ingrandimento superficie  
Surface enlargement  
Ampliacion superficie

RUGOSITÀ DELLE SUPERFICIE  
SURFACE ROUGHNESS  
RUGOSIDAD DE LA SUPERFICIE

70 my

SPESSORE  
THICKNESS  
ESPESOR

0,16 mm

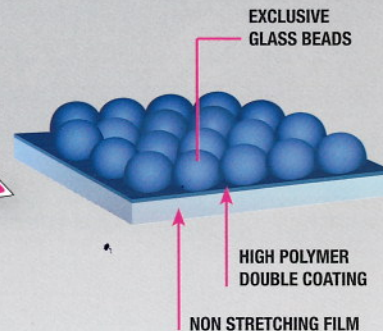
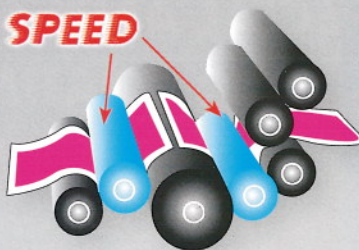

Il primo "esclusivo" prodotto di lavaggio universale specifico per la pulizia di qualsiasi sistema antimacchia con supporto in poliestere  
The first and "unique" universal product specific for the cleaning of any anti-marking system with substrate in polyester  
El primero y "unico" producto universal especifico para la limpieza de cualquier sistema antirrepinte con soporte de poliester

Su richiesta possiamo fornire qualsiasi formato di SPEED FILM e SPEED PAPER completi di biadesivo già applicato ai bordi di ogni foglio

On specific request we can supply any size of SPEED FILM and SPEED PAPER complete with bi-adhesive strips already attached to the edges of each sheet

Bajo pedido podemos suministrar cualquier formato de SPEED FILM y SPEED PAPER con el biadesivo ya aplicado en el borde de cada hoja



ADESIVO / ADHESIVE / ADHESIVO

NON ADESIVO / NON-ADHESIVE / NO ADHESIVO



Ingrandimento superficie  
Surface enlargement  
Ampliacion superficie

RUGOSITÀ DELLE SUPERFICIE  
SURFACE ROUGHNESS  
RUGOSIDAD DE LA SUPERFICIE

170 my

SPESSORE  
THICKNESS  
ESPESOR

0,37 mm



"SPEED FILM BLUE" è realizzato su un supporto in poliestere. È fornito nella versione "adesiva" e "non adesiva". Il supporto repellente "SPEED FILM BLUE" è stato creato per risolvere e prevenire i problemi di sporco ed accumulo di inchiostro sui cilindri di trasferimento prima che l'inchiostro si asciughi. La risposta a questo problema è "SPEED FILM BLUE" (nella versione adesiva e non). "SPEED FILM BLUE" grazie alla sua eccezionale superficie garantisce una stampa di alta qualità riducendo al minimo lo spreco di carta.



"SPEED FILM BLUE" is made on a polyester substrate. It can be supplied in the "adhesive" or "non-adhesive" version. "SPEED FILM BLUE" has been created to prevent and solve problems with dirt and ink build-up on transfer cylinders. Increasingly higher speeds of offset printing machines mean that printed sheets pass between transfer cylinders before the ink has dried. "SPEED FILM BLUE" (in the adhesive and non adhesive version) is the answer to this problem. "SPEED FILM BLUE", thanks to its exceptional surface, guarantees high quality printing and reduces paper waste to a minimum.



"SPEED FILM BLUE" está realizado sobre un soporte de poliéster. Se suministra en las versiones "Adhesivo" y "No Adhesivo". El soporte repellente "SPEED FILM BLUE" ha sido creado para resolver y prevenir los problemas de suciedad y acumulación de tinta sobre los cilindros de transferencia antes de que la tinta se seque. La respuesta a este problema es el "SPEED FILM BLUE" (en la versión adhesiva o no). "SPEED FILM BLUE" gracias a su excepcional superficie garantiza una impresión de alta calidad reduciendo al mínimo las máculas.

ADESIVO / ADHESIVE / ADHESIVO

NON ADESIVO / NON-ADHESIVE / NO ADHESIVO

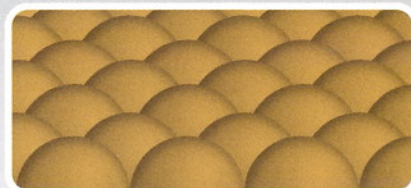

Ingrandimento superficie  
Surface enlargement  
Ampliacion superficie

RUGOSITÀ DELLE SUPERFICIE  
SURFACE ROUGHNESS  
RUGOSIDAD DE LA SUPERFICIE

130 my

SPESSORE  
THICKNESS  
ESPESOR

0,27 mm



"SPEED PAPER" è realizzato su supporto di carta, ed è realizzato esclusivamente nella versione "non adesiva". Il supporto "SPEED PAPER/CARTA" è stato creato per risolvere e prevenire i problemi di sporco ed accumulo di inchiostro sui cilindri di trasferimento prima che l'inchiostro si asciughi. La risposta a questo problema è "SPEED PAPER/CARTA". "SPEED PAPER/CARTA" grazie alla sua eccezionale superficie, garantisce una stampa di alta qualità riducendo al minimo lo spreco di carta.



"SPEED PAPER" is made on a paper substrate and is only available in the "non-adhesive" version. "SPEED PAPER" has been created to prevent and solve problems with dirt and ink build-up on transfer cylinders. Increasingly higher speeds of offset printing machines mean that printed sheets pass between transfer cylinders before the ink has dried. "SPEED PAPER" is the answer to this problem. "SPEED PAPER" thanks to its exceptional surface, guarantees high quality printing and reduces paper waste to a minimum.



"SPEED PAPER" está realizado sobre un soporte de papel y exclusivamente en la versión "No Adhesivo". El soporte "SPEED PAPER/PAPEL" ha sido creado para resolver y prevenir los problemas de suciedad y acumulación de tinta sobre los cilindros de transferencia antes de que la tinta se seque. La respuesta a este problema es "SPEED PAPER/PAPEL". "SPEED PAPER/PAPEL" gracias a su excepcional superficie garantiza una impresión de alta calidad reduciendo al mínimo las máculas.



## ROLAND (OLD MODELS)

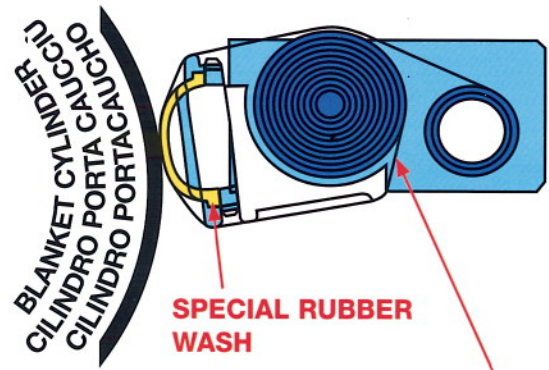
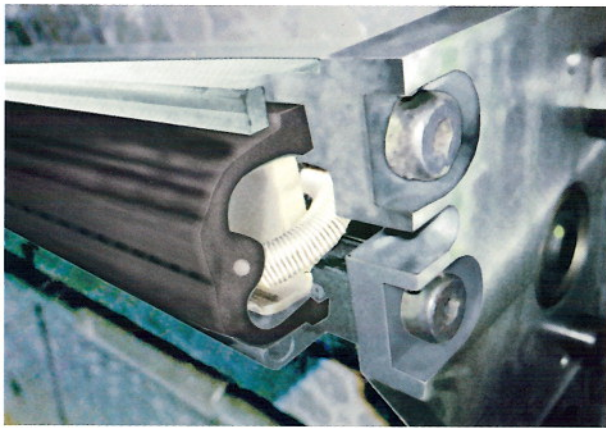

TESSUTO LAVACAUCIU  
AUTOMATIC WASHING BLANKET  
TEJIDO LAVA-CAUCHO

## MANROLAND 704 - POLYMAN ROTOMAN - LITHOMAN (P400)

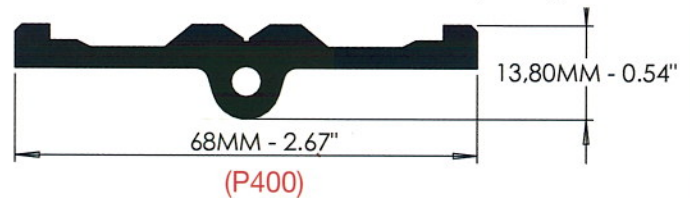

WITH SPRAY BAR INCORPORATED



CODICI / CODES / CODIGOS  
27.21322 - 27.21326 - 27.21327

- RICHIEDETE IL LISTINO DETTAGLIATO DEI DIVERSI MODELLI DI MACCHINA
- REQUEST DETAILS AND PRICES OF THE VARIOUS MACHINE MODELS
- SOLICITE LA LISTA DETALIADA DE LOS DISTINTOS MODELOS DE MAQUINA

CHIAVE DI MONTAGGIO PER MEMBRANE BALDWIN  
MOUNTING BAR FOR BALDWIN BLADDERS  
LLAVE DE MONTAJE PARA MEMBRANA BALDWIN

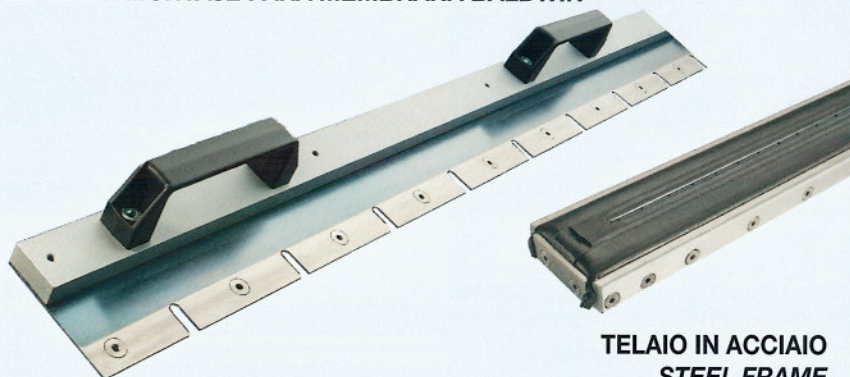

TELAIO IN ACCIAIO  
STEEL FRAME  
CHASIS EN ACERO

**NEW**

SERVIZIO MONTAGGIO MEMBRANA  
BLADDER MOUNTING SERVICE  
SERVICIO MONTAJE MEMBRANA

- Se ci inviate il telaio con la vecchia membrana consumata, la sostituiamo con la nuova membrana.
- If you send us the steel frame with the old used bladder, we will replace it for you with the new one.
- Si nos envia el chasis con la membrana desgastada, se lo sustituiamos con la nueva membrana.



# BLANKET AUTOWASH BRUSHES

SPAZZOLE LAVACAUCCIÙ  
CEPILLOS LAVACAUCHOS

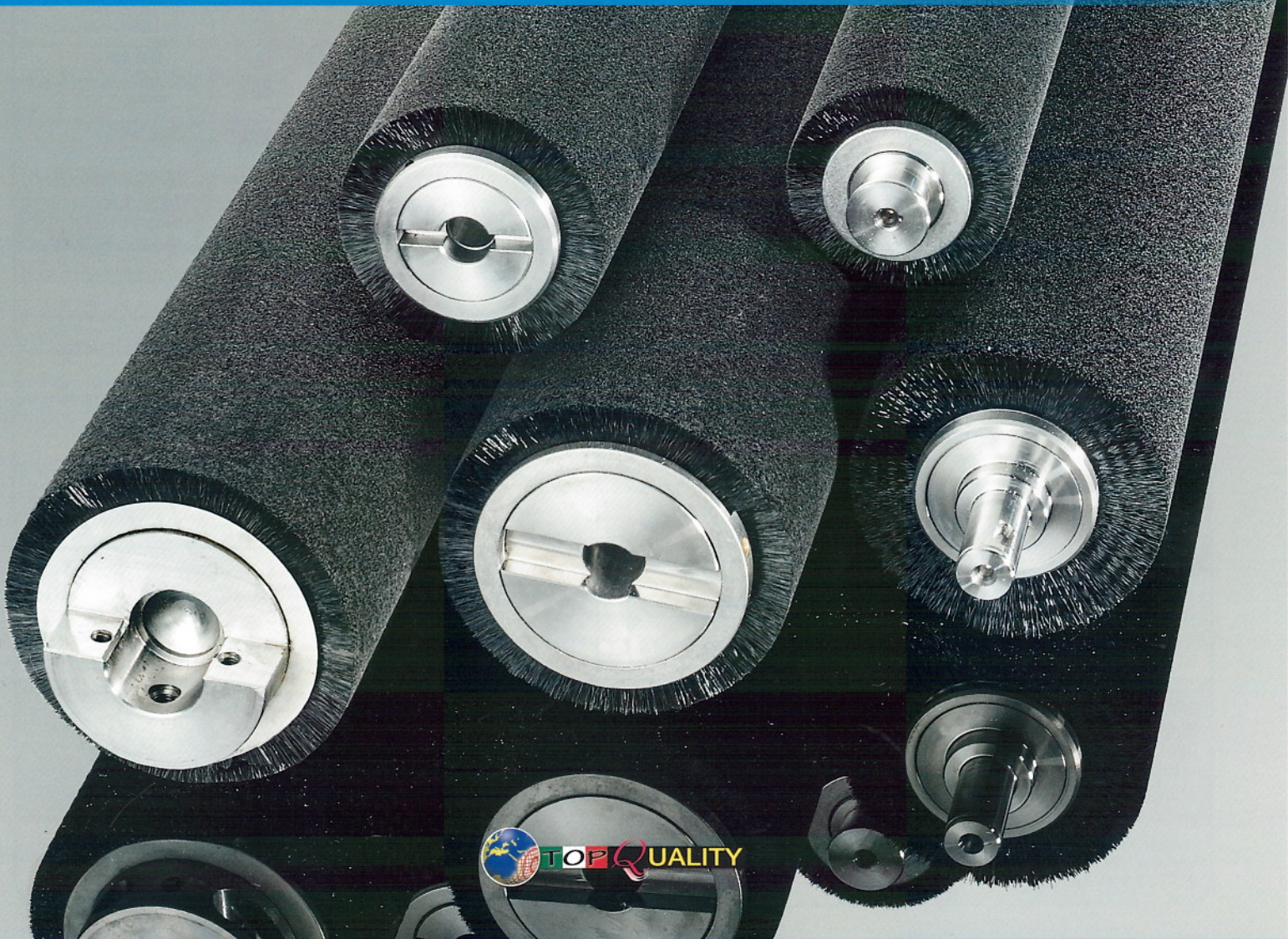

**Original**

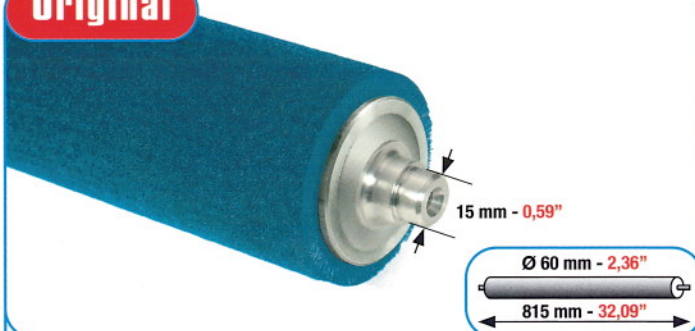

SPAZZOLA LAVACILINDRO STAMPA PER:  
CYLINDER AUTOWASH BRUSH FOR:  
CEPILLO LAVACILINDROS DE IMPRESIÓN PARA:

**ROLAND 300**  
TUTTI I MODELLI - ALL MODELS - TODOS LOS MODELOS

CODICE  
CODE - CÓDIGO

**4906**

**Original**

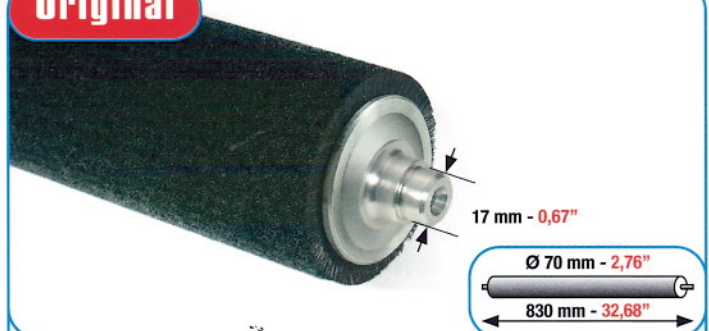

SPAZZOLA LAVACAUCCIÙ PER:  
BLANKET AUTOWASH BRUSH FOR:  
CEPILLO LAVACAUCHOS PARA:

**ROLAND 300**  
TUTTI I MODELLI - ALL MODELS - TODOS LOS MODELOS

CODICE  
CODE - CÓDIGO

**4909**



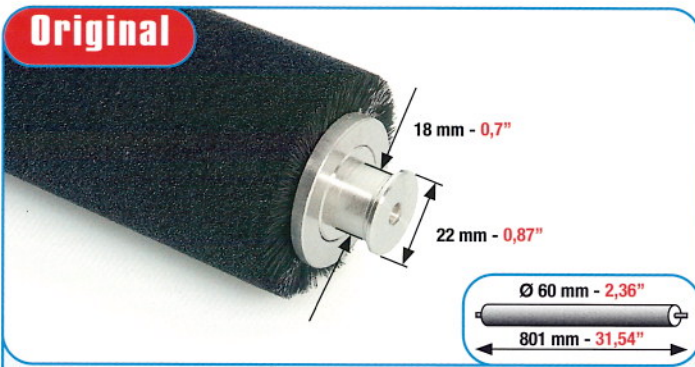

SPAZZOLA LAVACAUCCIÙ PER:  
BLANKET AUTOWASH BRUSH FOR:  
CEPILLO LAVACAUCHOS PARA:

**ROLAND 500**  
TUTTI I MODELLI - ALL MODELS - TODOS LOS MODELOS

	CODICE CODE - CÒDIGO	
	<b>4909-A</b>	

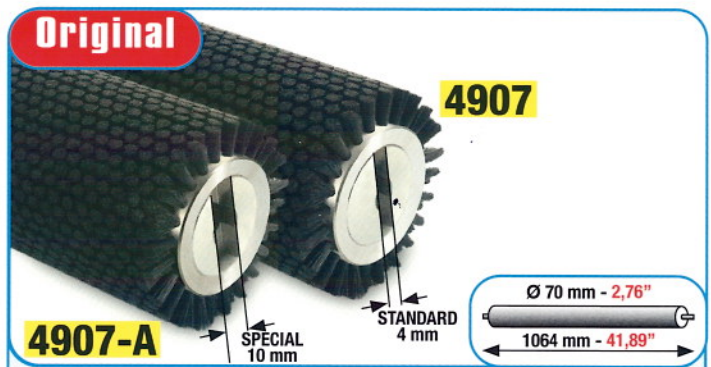

SPAZZOLA LAVACAUCCIÙ E LAVACILINDRO STAMPA PER:  
BLANKET & CYLINDER AUTOWASH BRUSH FOR:  
CEPILLO LAVACAUCHOS Y LAVACILINDROS DE IMPRESIÓN PARA:

**ROLAND 700**  
TUTTI I MODELLI - ALL MODELS - TODOS LOS MODELOS

	CODICE CODE - CÒDIGO	
	<b>4907</b>	
	<b>4907-A</b>	

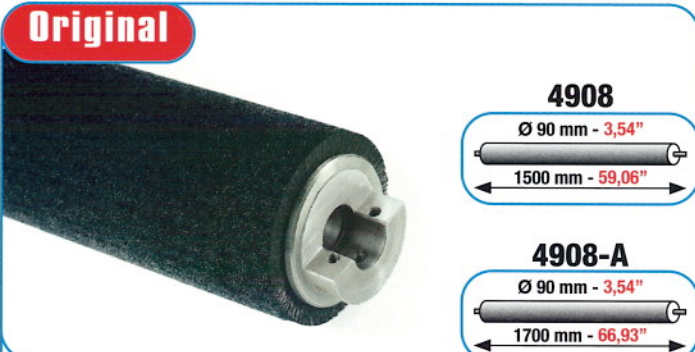

SPAZZOLA LAVACAUCCIÙ E LAVACILINDRO PER:  
BLANKET & CYLINDER AUTOWASH BRUSH FOR:  
CEPILLO LAVACAUCHOS Y LAVACILINDROS DE IMPRESIÓN PARA:

**ROLAND 900**  
TUTTI I MODELLI - ALL MODELS - TODOS LOS MODELOS

ORDINE MINIMO 5 PEZZI MINIMUM ORDER 5 PCS PEDIDO MINIMO 5 PIEZAS	CODICE CODE - CÒDIGO	
	<b>4908</b>	
	<b>4908-A</b>	



BARRA STRIZZA SPAZZOLA PER:  
BRUSH - WRINGING BAR FOR:  
BARRA ESCURRIDORA CEPILLO PARA:

**ROLAND 900**  
TUTTI I MODELLI - ALL MODELS - TODOS LOS MODELOS

	CODICE CODE - CÒDIGO	
	<b>27.21206</b>	

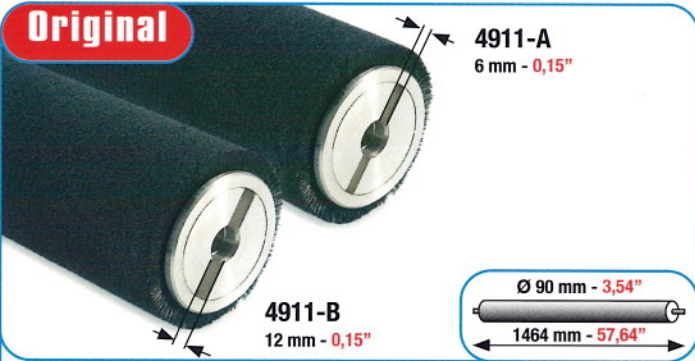

SPAZZOLA LAVACAUCCIÙ E LAVACILINDRO PER:  
BLANKET & CYLINDER AUTOWASH BRUSH FOR:  
CEPILLO LAVACAUCHOS Y LAVACILINDROS DE IMPRESIÓN PARA:

**ROLAND 900 NEW MODEL**  
TUTTI I MODELLI - ALL MODELS - TODOS LOS MODELOS

ORDINE MINIMO 5 PEZZI MINIMUM ORDER 5 PCS PEDIDO MINIMO 5 PIEZAS	CODICE CODE - CÒDIGO	
	<b>4911-A</b>	
	<b>4911-B</b>	

È vietata la riproduzione di ogni singola o parziale fotografia del presente catalogo, tutti i diritti sono riservati. - Any reproduction in whole or in part of this catalogue, is strictly prohibited. All rights reserved. - Se prohíbe terminante-mente la reproducción total o parcial de cada fotografia contenida en este catálogo. Todos los derechos están reservados. ممنوع الأستنساخ من كل أو بعض هذا الدليل منعاً باتاً. كل الحقوق محفوظة





# Il Top Quality nel Mondo

Top Quality Worldwide - El Top Quality en el Mundo

**BLU-TEX MARINE®**



**WHITE TEX®**



**BLU-TEX®**



**SPIDER TEX**



**PRE-TEX®**



**FOILTEX**



**MICROTEX**



**PERFECTING TEX®**



**SONTARA PRINTMASTER®**



**PRETEX AETERNUM PACK**



**BOBINE E MINIBOBINE DI TESSUTO  
PER IMPIANTI LAVACAUCIU' E LAVACILINDRO**

**JUMBO AND MINI WASHCLOTH ROLLS  
FOR BLANKET AND CYLINDER WASHING SYSTEMS**

**BOBINAS Y MINI-BOBINAS DE TEJIDO  
PARA INSTALACIONES LAVA-CAUCHOS Y LAVA-CILINDROS**

M.A.N. ROLAND	MM	INCH
ROLAND 200	745	29,33"
ROLAND REKORD III B	1050	41,34"
ROLAND 600	1050	41,34"
ROLAND 700	1050	41,34"
ROLAND 800/5	1340	52,76"
ROLAND 800/6	1440	56,69"
ROLAND ULTRA 6	1440	56,69"
ROLAND 800/7	1640	64,57"
M.A.N. GSH5/M.A.N. 6	1300	51,18"
M.A.N. GSH6	1460	57,48"
M.A.N. GSH7/M.A.N. 7	1640	64,57"
M.A.N. - MILLER TP74	750	29,53"
M.A.N. - MILLER TP 104 (1040)	1060	41,73"
M.A.N. - MILLER TP 104 (1060)	1080	42,52"

M.A.N. ROLAND WEB OFFSET	MM	INCH
OCTOMAN	680	26,77"
ROTHOMAN 30-35-40-45/B-C-D-M	985	38,78"
POLYMAN - LITHOMAN IV	985	38,78"
LITHOMAN 4	1010	39,76"
LITHOMAN III	1226	48,27"
LITHOMAN III	1227	48,31"
LITHOMAN III	1229	48,39"
LITHOMAN III	1350	53,15"
GEOMAN	1400	55,12"
LITHOMAN IV	1440	56,69"
LITHOMAN IV	1480	58,27"
EUROMAN	1493	58,78"
UNIMAN	1535	60,43"
COLORMAN 35	1670	65,75"
COLORMAN 30/35	1710	67,32"
UNIMAN	1720	67,72"
COLORMAN 30	1800	70,87"
LITHOMAN IV	2000	78,74"
LITHOMAN	2080	81,89"
LITHOMAN N80	2270	89,37"



***THE REASONS BEHIND OUR WORLDWIDE SUCCESS!!***

# BLU-TEX® WHITE-TEX®

# BLU-TEX® MARINE



**OUR CLOTHS**

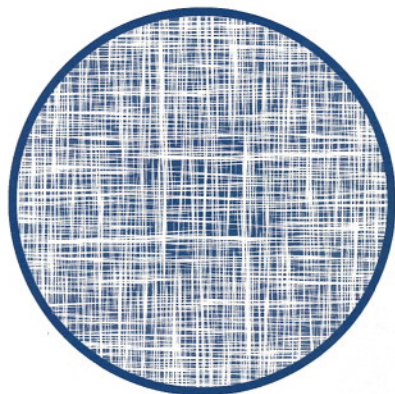

**INTERLACED FIBRE**



**MECHANICAL RESISTANCE**

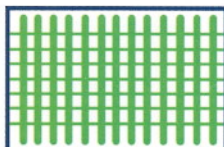

**HOLDS THE SOLVENT MORE UNIFORMLY AND WASHES WITH FEWER CONTACTS. YOU SAVE CONSUMPTION OF CLOTH AND TIME.**

**TOP QUALITY PRODUCT**

**COMPETITOR'S CLOTH**

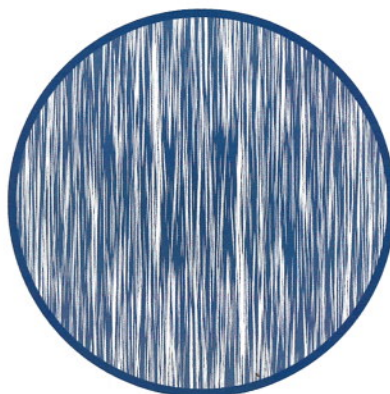

**PARALLEL FIBRE**



**MECHANICAL RESISTANCE**

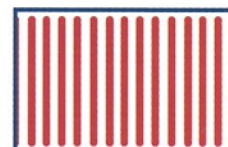

**DOES NOT HOLD THE SOLVENT WELL AND WASHES WITH MORE CONTACTS CONSUMING MORE CLOTH AND MORE TIME.**

**LOW QUALITY PRODUCT**

**AND YOU.. IF THEY HAD THE SAME PRICE WHICH ONE WOULD YOU CHOOSE?**



**WE HAVE THE ONLY WASHCLOTHS FOR PRINTERS WITH AN INTERLACED FIBRE!!**



**NEW PRODUCT**  
The Number One



# SPIDER TEX

**UNIVERSAL MICRO-PERFORATED WASHCLOTH!**

*\*for sheetfed offset and web offset presses*



## SPECIAL CLOTH

WITH EXCELLENT CLEANING CAPACITY FOR BOTH **PRINTING BLANKETS** AND **PERFECTING CYLINDERS**.

- ABRASION RESISTANCE	●●●●○
- RAPID ABSORPTION	●●●●○
- INK REMOVAL	●●●●●
- PAPER DUST REMOVAL	●●●●●
- LINTING	●○○○○

JUMBO ROLLS OF 350 LINEAR METRES OR MINI-ROLLS AVAILABLE IN ANY WIDTH!



[www.pavanvr.com](http://www.pavanvr.com)



# PRE-TEX®

CMIS  
PATENTED PRODUCTION  
SYSTEM TECHNOLOGY

Mini rotolini pre-impregnati per sistemi di pulizia automatici  
*Pre-impregnated mini-rolls for automatic washing systems*  
*Mini rollos pre-impregnados para sistemas automáticos de limpieza*

**MANROLAND**



For "Traditional inks"  
For "LEC UV"  
For "LED Technology"



I didn't want to believe it but...  
It really is FANTASTIC!



## CMIS technology®

Sistema di Impregnazione Micrometrica Controllata  
(PROCESSO DI PRODUZIONE BREVETTATO)

Controlled Micrometric Impregnation System  
PATENTED

Sistema de Impregnación Micrométrica Controlada





Pre-impregnated mini-rolls for automatic washing systems

**MAXIMUM RESULTS - MINIMUM WASTE - MAXIMUM SAVING**

**10 reasons why PRE-TEX® is UNIQUE**

- All Pre-TEX® solvents are **ISEGA certified**
- **Ready for use:** no preparation is needed
- Uniform impregnation, **NOT soaked to saturation** (immersion)
- Re-start-up with **minimal waste**, every other system creates a lot more
- Micrometric impregnation, no wash on the plate, **no fogging**
- Optimization of washing programmes **without wasting cloth**
- **No loss** of wash on the grippers and moving parts of the press
- Every wash guaranteed to be **perfect in all the printing units**
- **Wash times** drastically reduced by half, also in the large size presses
- Vacuum sealed, safe storage, **unlimited shelf life**



The most complete programme of pre-impregnated washcloth rolls on the market, suitable for all **Offset and Web-Offset machines**, available in all sizes and for use with all kinds of inks: **TRADITIONAL, UV, HUV, HYBRID, COLDSET and HEATSET.**

The technical production procedure guarantees a **perfectly uniform and stable micrometric impregnation** on the complete surface of the washcloth roll. It guarantees a level of washing of incomparable quality, thanks to the perfect and **gradual release of the wash solvent.**



**Pre-TEX® is unbeatable !**



With a simple test you will have clear evidence of a considerable saving of time and a surprising number of washes !



Moreover, by eliminating the internal washing system, you will have a significant reduction of maintenance of the components subject to wear



The **high quality Pre-TEX® washes**, which guarantee a very good cleaning of the inks, were **studied for impregnation**, with parametres regarding the density, stability and tension-activity which are different to the normal washes used for standard wash procedures.

**Possibility of converting the washing systems in use.**

All the **Offset and Web-Offset machines** equipped with washing systems for blankets and impression cylinders, that use dry washcloth rolls, **are convertible to the Pre-TEX® system.**



# PRE-TEX® ECO SUSTAINABILITY

The technology of the printing press manufacturers has been following the progressive use of pre-impregnated washcloth rolls for many years. Today this technology is widely applied all over the world. We should not exclude the possibility that, in the near future, the continuous restrictions of the environmental regulations linked to the ecological impact in the working environment, will lead to the total elimination of the use of dispersion wash solvents in the printroom.



Pavan Forniture Grafiche S.p.A has created the first **conversion service** in the world market to **eliminate the dispersion of solvents in the working environment** and to **reduce the consumption of washcloth by 40% on all MANROLAND press models.**

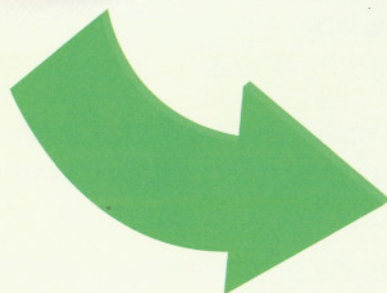

**Advantages in terms of:  
TIME, SOLVENT, CLOTH**

## LESS WATER

Much less water used in the press.



## LESS CLOTH

Lower cloth consumption for the same number of washes. Less washcloth to dispose of after use.



## LESS SOLVENT

No dispersion solvents in the printroom. Solvent is contained exclusively in the Pre-tex rolls.



## LESS POLLUTION !



**Pre-TEX® supports the environment !**  
As well as gaining more printing time, you will have a lower consumption of water in the press, a lower consumption of washcloth and a reduced dispersion of solvent.



NUM PACK Patented - AETERNUM PACK Patented - AETERNUM PACK Patented - AETERNUM PACK Patented - AETERNUM PACK Patented



# PRE-TEX®

## FOR WEB-OFFSET



*"Pavan Forniture Grafiche S.p.A thanks all their clients who over these 10 years have chosen PRE-TEX WEB for their Goss - Heidelberg - Manroland - KBA Wifag - Komori - Mitsubishi - Timson presses."*

**12 Years of PRE-TEX® WEB-OFFSET**  
**12 Years of sales worldwide**  
**12 Years of technological innovation**  
**12 Years of QUALITY.**

Luca Pavan

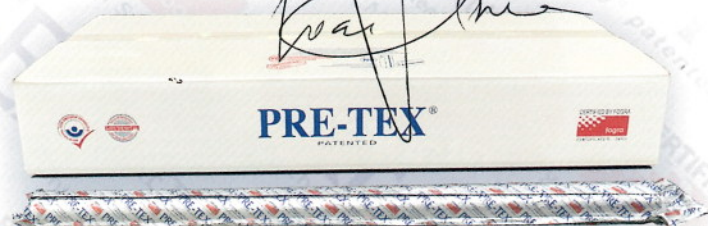
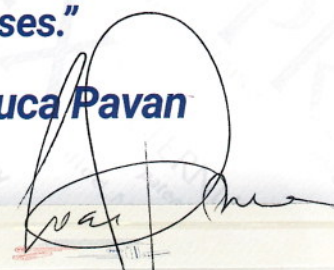

PACK Patented - AETERNUM PACK Patented - AETERNUM PACK Patented - AETERNUM PA





# SUMITOMO RUBBER INDUSTRIES

**DISTINCTIVE BLANKETS - MADE IN JAPAN**



## S-PRIA BLUE PLUS

COLOUR	DARK BLUE	CONSTRUCTION	3 FABRIC LAYERS
ROUGHNESS (Ra)	0,9 µm	HARDNESS (TOTAL)	79° SHORE A
APPLICATION FIELDS	SHEETFED, METAL DECORATING, PACKAGING	INK COMPATIBILITY	CONVENTIONAL AND UV INKS
THICKNESS mm	1,96 ± 0,01 mm	COMPRESSIBILITY	28-42 KG/CM² A 0,32 mm DEFORMATION

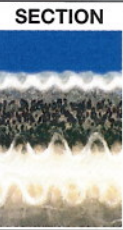

## S-PRIA WEB

COLOUR	BLUE	CONSTRUCTION	3 FABRIC LAYERS
ROUGHNESS (Ra)	1,0 µm	HARDNESS (TOTAL)	79° SHORE A
APPLICATION FIELDS	WEB OFFSET	INK COMPATIBILITY	CONVENTIONAL AND UV INKS
THICKNESS mm	1,70 ± 0,01 mm	COMPRESSIBILITY	28-42 KG/CM² A 0,32 mm DEFORMATION



## SB 14

COLOUR	VIOLET	CONSTRUCTION	3 FABRIC LAYERS
ROUGHNESS (Ra)	0,7 µm	HARDNESS (TOTAL)	79° SHORE A
APPLICATION FIELDS	SHEETFED, METAL DECORATING, PACKAGING	INK COMPATIBILITY	UV FOR "H-UV" - "LE-UV" - "LEC-UV" - "HR-UV"
THICKNESS mm	1,96 ± 0,01 mm	COMPRESSIBILITY	28-42 KG/CM² A 0,32 mm DEFORMATION



## MASTER STRIP

COLOUR	BLUE	CONSTRUCTION	3 FABRIC LAYERS
ROUGHNESS (Ra)	0,7 µm	HARDNESS (TOTAL)	80° SHORE A
APPLICATION FIELDS	VARNISHING GROUP	INK COMPATIBILITY	70% ACRYLIC VARNISH, 30% UV VARNISH
THICKNESS mm	1,96 ± 0,01 mm	COMPRESSIBILITY	650 N/3 CM²



### CHECK OUT THE VIDEO

High performance offset blanket for Sheet-fed & Web-offset  
**PRINTING Blankets**



# ROYAL DOT

**AL VERTICE DELLA QUALITÀ  
THE SUMMIT OF QUALITY  
EN LA CUMBRE DE LA CALIDAD**

High performance  
offset blanket for  
Sheet-fed & Web-offset  
**Printing  
Blankets**



**THE BEST QUALITY  
FOR MANROLAND MACHINES**



UNIQUE PRODUCTION TECHNOLOGY

*If you mount them correctly .....  
.... you will love them !!!*

**N.T.L.T.®**  
No Thickness Loss technology

**ROYAL DOT DYNAMIC BLANKETS®**  
THE BEST QUALITY PROGRAMME OF COMPRESSIBLE PRINTING BLANKETS

**THE ONLY PRINTING BLANKETS  
THAT DO NOT LOSE "THICKNESS" !!!**

**CORRECT PACK**  
Correct thickness maintained after mounting

**INCORRECT PACK**  
Increased pack thickness

**RULE FOR THE OPTIMAL MOUNTING OF PRINTING BLANKETS**

The innovative production technology of this product requires that you **DO NOT ADD** the thickness of the total pack (blanket + underpack-rol) as indicated in the **technical manual**.

**DO NOT ADD** **DO NOT ADD**

If you respect this indication, you are guaranteed the maximum quality performance and durability of the product.

**ISEGA APPROVED** for food, toy and medical industry

 **30 Anni di esperienza  
e di continui successi!!**

 **30 Years of experience  
and continuous success!!**

 **¡¡30 Años de experiencia y  
de continuos exitos!!**

L'esperienza maturata ed acquisita in tutti questi anni nella commercializzazione dei tessuti gommati, ci ha permesso di selezionare un'esclusiva gamma di prodotti specifici risultati essere i migliori nel loro impiego. Abbiamo scelto il meglio che il mercato mondiale oggi propone!! La gamma di tessuti gommati "ROYAL DOT DYNAMIC" è interamente certificata sotto il marchio di garanzia "ROYAL DOT DYNAMIC". Su richiesta l'intera gamma di tessuti gommati "ROYAL DOT DYNAMIC" può essere fornita con una vostra etichetta privata personalizzata. Contattateci per avere maggiori informazioni in merito.

The experience we have gathered and acquired in all these years of selling printing blankets has allowed us to select an exclusive range of products whose performance is at the top of the scale. We have chosen the best that today's market offers!! The "ROYAL DOT DYNAMIC" range of printing blankets is entirely certified under the guaranteed trademark "ROYAL DOT DYNAMIC". On request, the complete range of "ROYAL DOT DYNAMIC" printing blankets can be supplied with your own private personalized label. Contact us for further details.

La experiencia madurada y conseguida en todos estos años, en la comercialización de cauchos, nos ha permitido el seleccionar una gama exclusiva de productos específicos resultando ser los mejores. ¡¡Hemos escogido lo mejor que hoy propone el mercado mundial!! La gama de cauchos "ROYAL DOT DYNAMIC" esta certificada completamente bajo la marca de garantía "ROYAL DOT DYNAMIC". Bajo pedido, la gama completa de cauchos "ROYAL DOT DYNAMIC" se puede suministrar con su etiqueta privada personalizada. Contactenos para tener mayor información al respecto.





## ROYAL DOT "6000" DYNAMIC

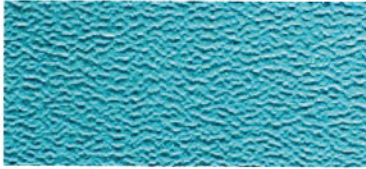

COLOUR	BLUE	CONSTRUCTION	3 FABRIC LAYERS
ROUGHNESS (Ra)	0,8 ~ 1,0 µm	HARDNESS (TOTAL)	77° SHORE A
APPLICATION FIELDS	SHEETFED, HEATSET, COLDSET	INK COMPATIBILITY	CONVENTIONAL AND UV INKS
THICKNESS mm	1,70 / 1,95 ± 0,01mm	COMPRESSIBILITY	20-35 KG/CM <sup>2</sup> A 0,23 mm DEFORMATION



## ROYAL DOT "5500" DYNAMIC



COLOUR	LIGHT BLUE	CONSTRUCTION	3 FABRIC LAYERS
ROUGHNESS (Ra)	0,8 ~ 1,0 µm	HARDNESS (TOTAL)	77° SHORE A
APPLICATION FIELDS	SHEETFED, METAL DECORATING, PACKAGING	INK COMPATIBILITY	CONVENTIONAL AND UV INKS
THICKNESS mm	1,95 ± 0,01mm	COMPRESSIBILITY	20-35 KG/CM <sup>2</sup> A 0,23 mm DEFORMATION

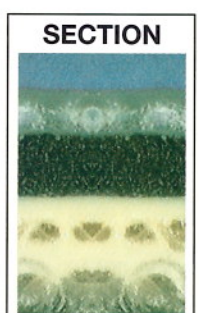

## ROYAL DOT MASTER



COLOUR	DARK BLUE	CONSTRUCTION	3 FABRIC LAYERS
ROUGHNESS (Ra)	0,8 ~ 1,0 µm	HARDNESS (TOTAL)	77° SHORE A
APPLICATION FIELDS	SHEETFED, PACKAGING	INK COMPATIBILITY	CONVENTIONAL AND HYBRID INKS
THICKNESS mm	1,70 / 1,95 ± 0,01mm	COMPRESSIBILITY	20-35 KG/CM <sup>2</sup> A 0,23 mm DEFORMATION



## ROYAL DOT -KARTON-



COLOUR	DARK GREY	CONSTRUCTION	2 FABRIC LAYERS
ROUGHNESS (Ra)	0,5 ~ 0,7 µm	HARDNESS (TOTAL)	60° SHORE A
APPLICATION FIELDS	SPECIFIC FOR CORRUGATED BOARD	INK COMPATIBILITY	CONVENTIONAL INKS
THICKNESS mm	2,07 ± 0,01mm	COMPRESSIBILITY	18-32 KG/CM <sup>2</sup> A 0,21 mm DEFORMATION



## ROYAL DOT BLACK UV



COLOUR	BLACK	CONSTRUCTION	3 FABRIC LAYERS
ROUGHNESS (Ra)	ACCORDING TO APPLICATION	HARDNESS (TOTAL)	77° SHORE A
APPLICATION FIELDS	SHEETFED, METAL DECORATING, PACKAGING	INK COMPATIBILITY	UV FOR "H-UV" - "LE-UV" - "LEC-UV" - "HR-UV"
THICKNESS mm	1,70 / 1,95 ± 0,01mm	COMPRESSIBILITY	20-35 KG/CM <sup>2</sup> A 0,23 mm DEFORMATION







## ROYAL DOT UV PLUS



COLOUR	VIOLET	CONSTRUCTION	3 FABRIC LAYERS
ROUGHNESS (Ra)	ACCORDING TO APPLICATION	HARDNESS (TOTAL)	77° SHORE A
APPLICATION FIELDS	SHEETFED, COMMERCIAL WEB, PACKAGING	INK COMPATIBILITY	UV FOR "H-UV" - "LE-UV" - "LEC-UV" - "HR-UV"
THICKNESS mm	1,70 / 1,95 ± 0,01mm	COMPRESSIBILITY	20-35 KG/CM² A 0,23 mm DEFORMATION



## ROYAL DOT PLAST UV



COLOUR	BLACK	CONSTRUCTION	3 FABRIC LAYERS
ROUGHNESS (Ra)	0,4 ~ 0,6 µm	HARDNESS (TOTAL)	80° SHORE A
APPLICATION FIELDS	PLASTIC POT, TUBES	INK COMPATIBILITY	RESISTANT TO UV INKS
THICKNESS mm	1,70 / 1,95 ± 0,01mm	COMPRESSIBILITY	75 KG/CM² DEFORMATION



## ROYAL DOT WEB



COLOUR	DARK BLUE	CONSTRUCTION	3 FABRIC LAYERS
ROUGHNESS (Ra)	0,8 ~ 1,0 µm	HARDNESS (TOTAL)	77° SHORE A
APPLICATION FIELDS	WEB OFFSET	INK COMPATIBILITY	CONVENTIONAL AND HYBRID INKS
THICKNESS mm	1,70 / 1,95 ± 0,01mm	COMPRESSIBILITY	20-35 KG/CM² A 0,23 mm DEFORMATION

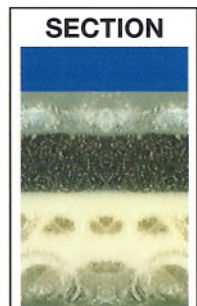

**CHECK OUT THE VIDEO**

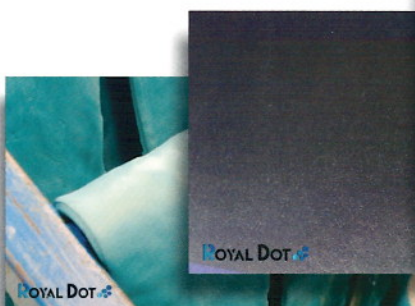



# NEW SERVICE SMART CUTTING

QUALITY, SPEED, ECONOMY



& ROYAL DOT



4 AUTOMATIC CUTTING SYSTEMS - 4 MANUAL CUTTING SYSTEMS  
3 BARRING STATIONS



NOW YOU CAN PURCHASE OUR VAST RANGE OF PRINTING BLANKETS AT A PURCHASE PRICE (RESERVED FOR BLANKET ROLLS) AS IF YOU HAD IN YOUR COMPANY A CONVERTING SYSTEM (CUTTING + BARRING)!





# **NEW SMART CUTTING SERVICE: ALL INCLUDED IN THE PRICE !!!**



## **1) CUTTING**

Printing blankets are cut to size from jumbo rolls using our automatic cutting systems.

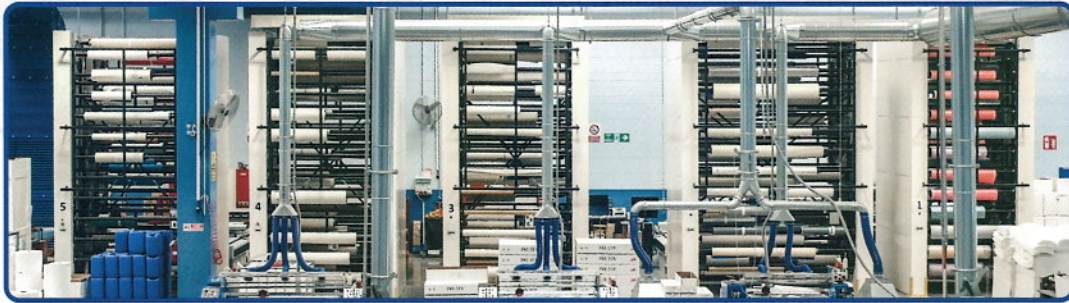

## **2) BARRING**

After the conversion, blankets are barred using our 4 presses (each press has a maximum width of 2200 mm).



## **3) STAMPING**

Each blanket is marked on the back with the blanket brand name and the dealer's contact details. Our company name will never appear.

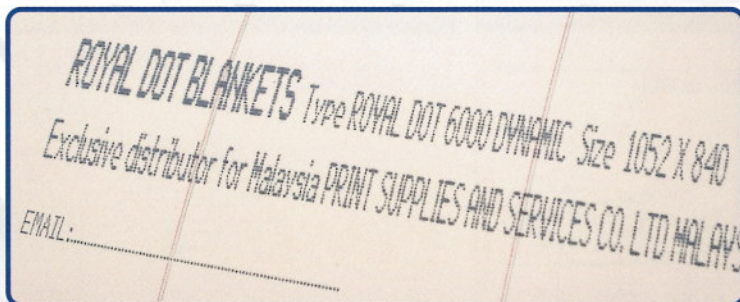

## **4) PACKAGING**

On the basis of the size and quantity of blankets, we pack them in rolls, ready for dispatch (in multiples of 4/5/6 pcs).



# QUICK CUT AND QUICK BAR SERVICE

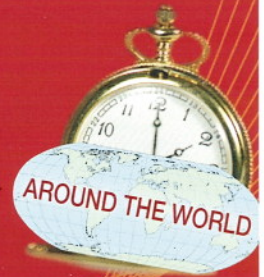

QUALITÀ, RAPIDITÀ, CONVENIENZA - QUALITY, SPEED, ECONOMY - CALIDAD, RAPIDEZ, CONVENIENCIA



**ROLAND 200 NEW MODEL**  
**ROLAND 700/900 - STEEL**

**BARRA IN ACCIAIO**  
**STEEL BAR**  
**BARRA EN ACERO**

**BARRA-BAR-BARRA**  
**31512 ZE**

**ROLAND 200/700/900**  
**ALUMINIUM**

**BARRA IN ALLUMINIO**  
**ALUMINIUM BAR**  
**BARRA EN ALUMINIO**

**BARRA-BAR-BARRA**  
**3342**

**ROLAND 300/500**

**BARRA IN ACCIAIO**  
**STEEL BAR**  
**BARRA EN ACERO**

**BARRA-BAR-BARRA**  
**31510 ZR**

**ROLAND 200 - ROLAND FAVORIT**

**BARRA IN ALLUMINIO**  
**ALUMINIUM BAR**  
**BARRA EN ALUMINIO**

**BARRA-BAR-BARRA**  
**34068**

**ROLAND REKORD - 600 - PARVA**

**BARRA IN ALLUMINIO**  
**ALUMINIUM BAR**  
**BARRA EN ALUMINIO**

**BARRA-BAR-BARRA**  
**19070**

**ROLAND M.A.N. - 800 - ULTRA**  
tutti i modelli-all models-todos los modelos

**BARRA IN ALLUMINIO**  
**ALUMINIUM BAR**  
**BARRA EN ALUMINIO**

**BARRA-BAR-BARRA**  
**19862**  
**ULTRA BAR**

**ROLAND M.A.N. - 800 - ULTRA**  
**SLAVE BAR**

**BARRA IN ALLUMINIO**  
**ALUMINIUM BAR**  
**BARRA EN ALUMINIO**

**BARRA-BAR-BARRA**  
**23175**  
**SLAVE BAR**

**ROLAND M.A.N. - 800 - ULTRA**

**BARRA IN ALLUMINIO**  
**ALUMINIUM BAR**  
**BARRA EN ALUMINIO**

**BARRA-BAR-BARRA**  
**ADATTATORE/CONNECTOR/ADAPTADORA**  
**MS01**



# ROYAL UNDERBLANKET®

THE MOST COMPLETE PROGRAMME  
OF THICKNESSES IN THE WORLD

THE ONLY  
UNDERBLANKET  
WITH GROUND  
RUBBER SURFACE

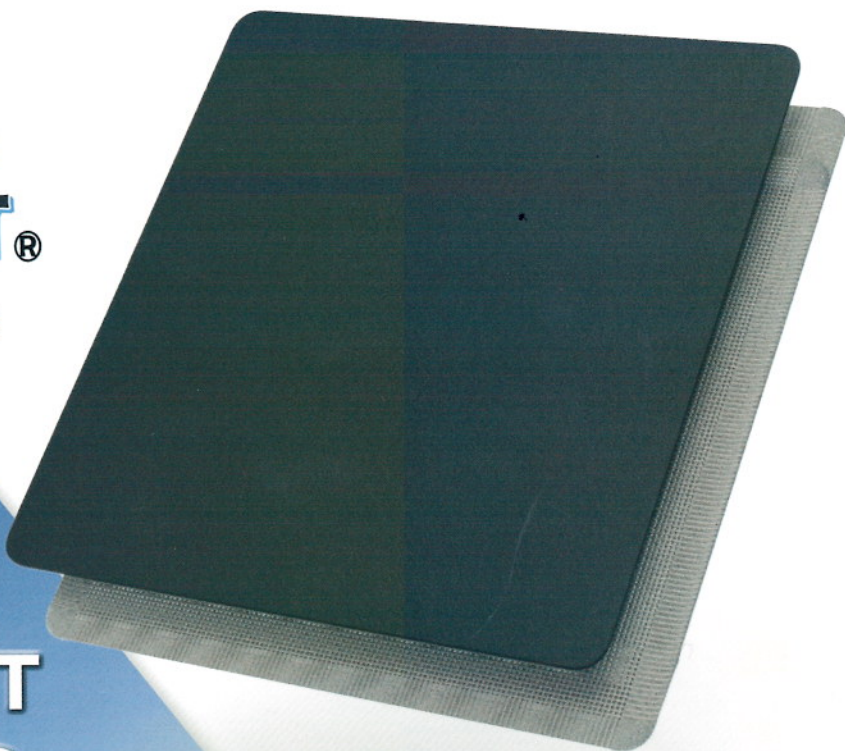

**HARDNESS:**

**75 SHORE**

**THICKNESSES  
AVAILABLE:**

MM: 0,40 - 0,45  
0,50 - 0,55 - 0,60 - 0,65  
0,70 - 0,75 - 0,80 - 0,90  
1,00 - 1,40 - 1,45 - 1,50.

**TOLERANCE:**

**+/-0,01**

**AVAILABLE IN CUT PIECES AND IN ROLLS**



fogra cert

FOGRA CERTIFICATION IN PREPARATION





# SUPER-PACK®



**CARTONCINI CALIBRATI DI ALTA QUALITÀ E PRECISIONE - I PRIMI CARTONCINI "CERTIFICATI" AL MONDO**  
**HIGH QUALITY AND PRECISION UNDERPACKING PAPER - THE FIRST CERTIFIED UNDERPACKING PAPERS IN THE WORLD**  
**ALZAS CALIBRADAS DE ALTA CALIDAD Y PRECISION - LOS PRIMEROS PAPELES CALIBRADOS "CERTIFICADOS" EN EL MUNDO**

Speciale trattamento repellenza al solvente  
*Special solvent - repellent treatment*  
 Tratamiento especial repelente al solvente



**SUPER-PACK®**

DOPO 30 MINUTI . AFTER 30 MINUTES . DESPUES DE 30 MINUTOS

PRODOTTO CONCORRENTE "MADE IN GERMANY" . COMPETITOR'S PRODUCT "MADE IN GERMANY"  
 PRODUCTO DE LA COMPETENCIA "MADE IN GERMANY"

DOPO 30 MINUTI . AFTER 30 MINUTES . DESPUES DE 30 MINUTOS

PRODOTTO DI ORIGINE ASIATICA . PRODUCT OF ASIAN ORIGIN . PRODUCTO DE ORIGEN ASIATICO

DOPO POCHI SECONDI . AFTER A FEW SECONDS . DESPUES DE POCOS SEGUNDOS

## MANROLAND

MISURE STANDARD "UFFICIALI"  
 "OFFICIAL" STANDARD SIZES  
 MEDIDAS ESTANDAR "OFICIALES"

ROLAND 50 / PRAKTICA 00	520 x 410
FAVORIT 01	650 x 530
PRAKTICA 01	670 x 480
FAVORIT 0B	730 x 595
ROLAND 200 / 300	740 x 605
ROLAND 500	745 x 620
ROLAND REKORD II / II B	915 x 680
ROLAND PARVA II / II B	915 x 680
ROLAND PARVA II / C	925 x 700
ROLAND REKORD III	975 x 720
ROLAND REKORD III B / 600	1030 x 795
ROLAND 700	1050 x 780
ROLAND ULTRA IV / 800 IV	1140 x 880
ROLAND ULTRA V / 800 V	1280 x 980
ROLAND 800 V	1280 x 1110
ROLAND ULTRA V / 800 / 900	1310 x 1000
ROLAND 800 V - MUNDIAL	1310 x 1110
ROLAND ULTRA VI / 800	1410 x 1110
ROLAND 800 / 6 - ULTRA 6 NEW	1410 x 1140
ROLAND 900	1440 x 1050
ROLAND ULTRA VI - VELT	1440 x 1110
ROLAND 800 VI	1450 x 1150
ROLAND 800 / ULTRA VII	1620 x 1190
ROLAND 800 / ULTRA VII B	1620 x 1270
ROLAND 900 VII B	1640 x 1250
ROLAND 900 XXL	1640 x 1290
ROLAND ULTRA VIII	1780 x 1270
ROLAND 900 XXL-8	1860 x 1320



**SUPER-PACK®**

**LA PIÙ VASTA GAMMA DI CARTONCINI CALIBRATI AL MONDO!**  
**THE LARGEST RANGE OF CALIBRATED PAPER IN THE WORLD!**  
**¡LA MAYOR GAMA DE TARJETAS CALIBRADAS DEL MUNDO!**



# PATENTED HIGHLANDER PACK INFINITY®

THE ONLY STRUCTURAL UNDERPACKING  
FOR PRINTING BLANKETS  
WITH HIGH DIMENSIONAL STABILITY  
AND A GROUND SURFACE  
(KEEPS THE THICKNESS STABLE)

**HIGHLANDER** is an innovative non-deformable underpacking that can be used under any printing blanket with the purpose of obtaining the absolutely **precise** thickness (Pack) in conformity with the indications in all the machine manufacturers' manuals.

The **Precision** and the **Maintaining** of the thickness are the most important characteristics of **HIGHLANDER** which differentiate it from any other similar product in the world and which guarantee a superior quality of dot printing.

**HIGHLANDER PACK INFINITY® NON-ADHESIVE** is produced in the following thicknesses:

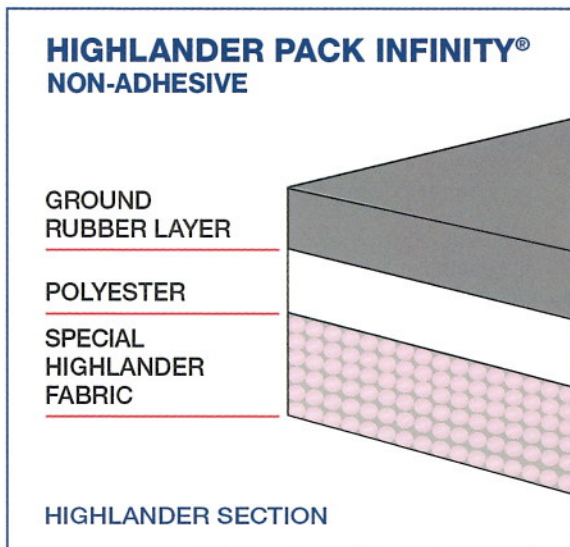
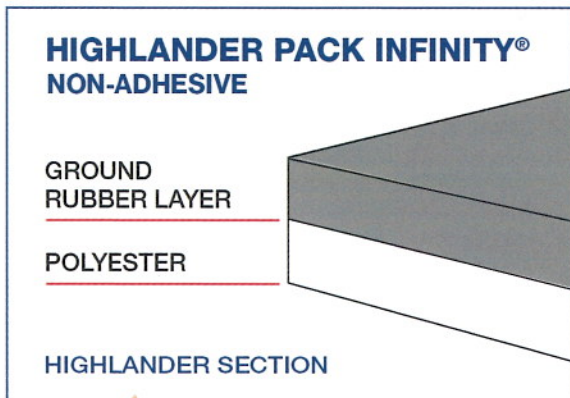

**HIGHLANDER PACK INFINITY® NON-ADHESIVE** is supplied in cut sheets and in rolls.

**HIGHLANDER** is manufactured using a special production system which guarantees a real dimensional stability superior to all other materials present in the market.

The dimensional stability of **HIGHLANDER** guarantees the complete maintaining of the thickness of all the Pack, ensuring a longer working life than any other system in use today.

**HIGHLANDER** is the only underpacking manufactured with the surface totally ground, thus guaranteeing a greater durability that is not comparable with any other known system.

**HIGHLANDER PACK INFINITY®** is made using a special fabric structure coupled with a layer of polyester and a layer of rubber.

**NEW!!**

**HIGHLANDER PACK INFINITY® ADHESIVE VERSION NOW AVAILABLE!**

**HIGHLANDER PACK INFINITY® ADHESIVE** is produced in the following thicknesses:

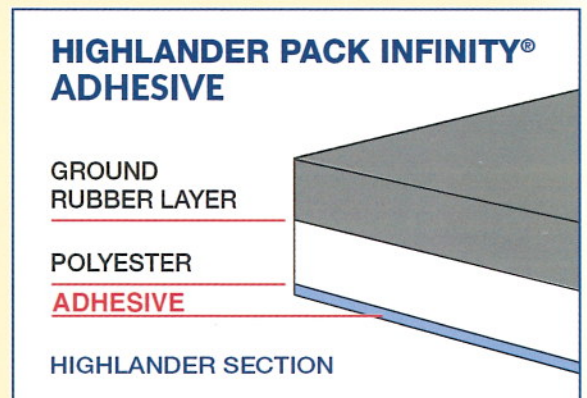

**HIGHLANDER PACK INFINITY® ADHESIVE** is supplied in cut sheets.



**ARTICOLI VARI  
SUNDRIES  
ARTICULOS VARIOS**



**Standard**

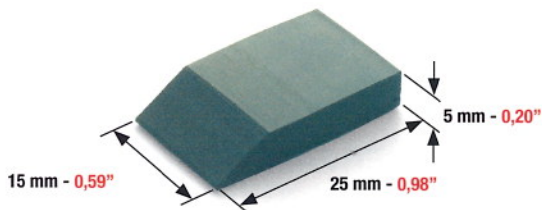

**RACCOGLI GRUMI IN GOMMA PER:  
RUBBER HICKEY REMOVER FOR:  
QUITAMOTAS DE GOMA PARA:**

**ROLAND**

ORDINE MINIMO 5 PEZZI  
MINIMUM ORDER 5 PCS  
PEDIDO MÍNIMO 5 PIEZAS

CODICE  
CODE - CÓDIGO

**3840**

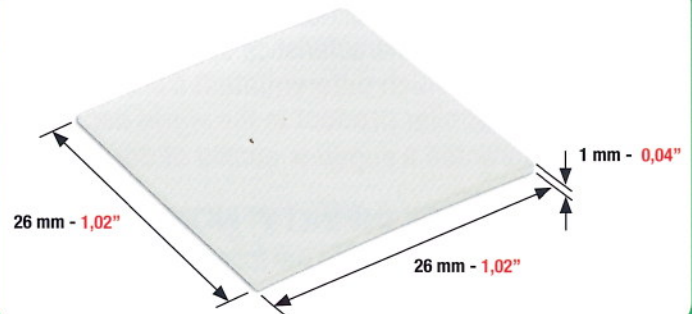

**RACCOGLI GRUMI IN PLASTICA PER:  
PLASTIC HICKEY REMOVER FOR:  
QUITAMOTAS DE PLÁSTICO PARA:**

**ROLAND 300**

ORDINE MINIMO 5 PEZZI  
MINIMUM ORDER 5 PCS  
PEDIDO MÍNIMO 5 PIEZAS

CODICE  
CODE - CÓDIGO

**3842**

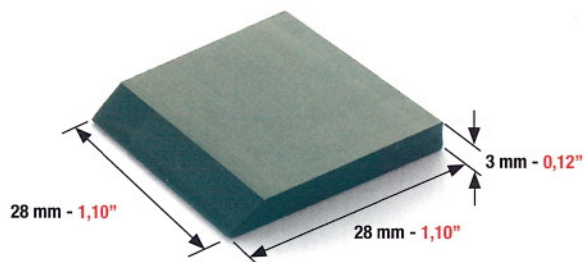

**RACCOGLI GRUMI IN GOMMA PER:  
RUBBER HICKEY REMOVER FOR:  
QUITAMOTAS DE GOMA PARA:**

**ROLAND 300**

ORDINE MINIMO 5 PEZZI  
MINIMUM ORDER 5 PCS  
PEDIDO MÍNIMO 5 PIEZAS

CODICE  
CODE - CÓDIGO

**3844**

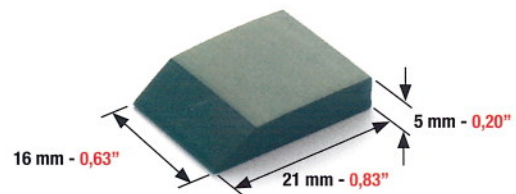

**RACCOGLI GRUMI IN GOMMA PER:  
RUBBER HICKEY REMOVER FOR:  
QUITAMOTAS DE GOMA PARA:**

**ROLAND REKORD / ROLAND 600**

ORDINE MINIMO 5 PEZZI  
MINIMUM ORDER 5 PCS  
PEDIDO MÍNIMO 5 PIEZAS

CODICE  
CODE - CÓDIGO

**3850**



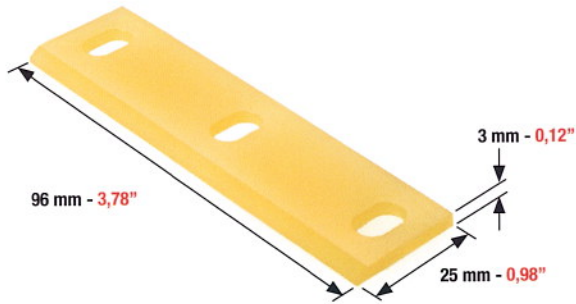

RACCOGLI GRUMI IN RESINA PER:  
HICKEY REMOVER IN RESIN FOR:  
QUITAMOTAS DE RESINA PARA:

**M.A.N. - ROLAND**

ORDINE MINIMO 5 PEZZI  
MINIMUM ORDER 5 PCS  
PEDIDO MÍNIMO 5 PIEZAS

CODICE  
CODE - CÓDIGO

**3860**

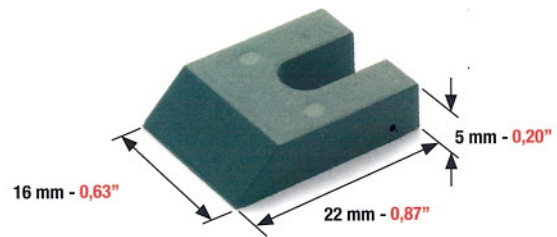

RACCOGLI GRUMI IN GOMMA PER:  
RUBBER HICKEY REMOVER FOR:  
QUITAMOTAS DE GOMA PARA:

**MIEHLE/ROLAND**

ORDINE MINIMO 5 PEZZI  
MINIMUM ORDER 5 PCS  
PEDIDO MÍNIMO 5 PIEZAS

CODICE  
CODE - CÓDIGO

**3880**

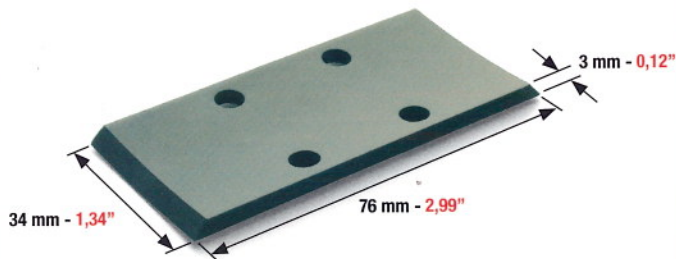

RACCOGLI GRUMI IN GOMMA PER:  
RUBBER HICKEY REMOVER FOR:  
QUITAMOTAS DE GOMA PARA:

**ROLAND 800**

ORDINE MINIMO 5 PEZZI  
MINIMUM ORDER 5 PCS  
PEDIDO MÍNIMO 5 PIEZAS

CODICE  
CODE - CÓDIGO

**3852**

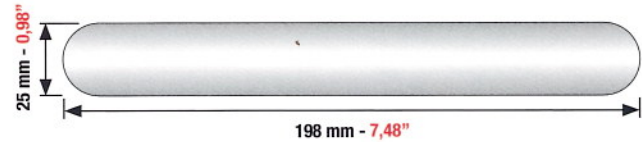

LAMETTA CALIBRATA PER LA REGOLAZIONE DELLA PRESSIONE  
DEI RULLI INCHIOSTRATORI  
GAUGED STEEL BLADE FOR ADJUSTMENT OF INKING ROLLER PRESSURE  
CUCHILLA PEQUEÑA EN ACERO, CALBRADA PARA LA REGULACIÓN  
DE LA PRESIÓN DE LOS RODILLOS ENTINTADORES

CONFEZIONE 4 PEZZI  
4 PCS PACKET  
CONFECCIONES DE 4 PIEZAS

CODICE  
CODE - CÓDIGO

**4630**

SPESSORE  
THICKNESS - GROSOR

0,10 mm 0,004"

**Special**

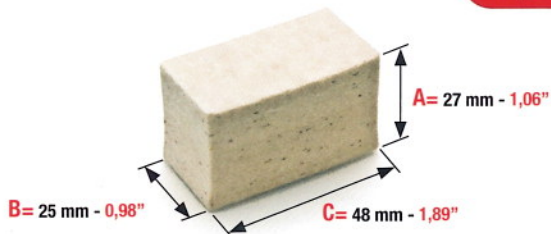

FELTRINO PER PULIZIA ANELLI PER:  
FELT FOR CLEANING RINGS FOR:  
FIELTRO PEQUEÑO PARA LA LIMPIEZA DE ANILLOS PARA:

**ROTOMAN**

CONFEZIONE DA 20 PEZZI  
PACKET OF 20 PCS  
CONFECCIÓN DE 20 PIEZAS

CODICE  
CODE - CÓDIGO

**5170**

**Special**

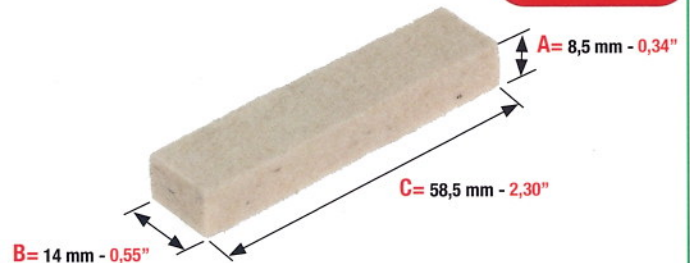

**ROTOMAN**

CONFEZIONE DA 20 PEZZI  
PACKET OF 20 PCS  
CONFECCIÓN DE 20 PIEZAS

CODICE  
CODE - CÓDIGO

**5168-B**



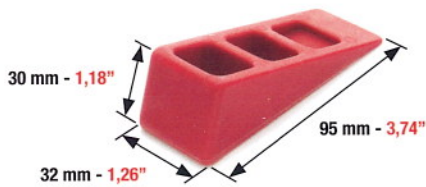

MISURA - SIZE - MEDIDA  
mm 30 x 32 x 95

**CUNEO MINI**  
**MINI PLASTIC WEDGE**  
**CUÑA MINI**

**BABY**

CODICE  
CODE - CÓDIGO

**5143**

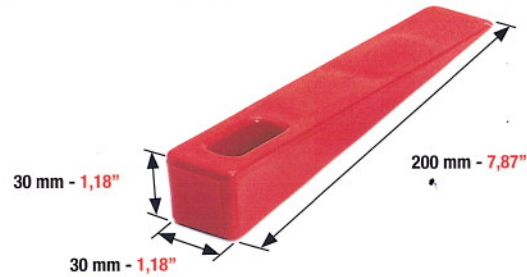

MISURA - SIZE - MEDIDA  
mm 30 x 30 x 200

**CUNEO PICCOLO**  
**SMALL PLASTIC WEDGE**  
**CUÑA PEQUEÑA**

**SMALL**

CODICE  
CODE - CÓDIGO

**5145**

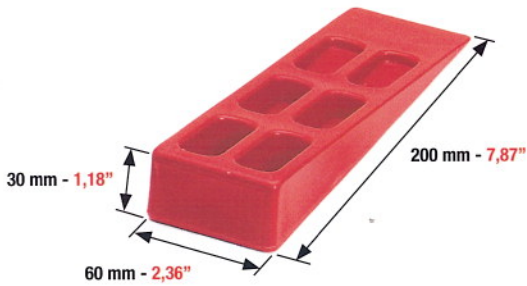

MISURA - SIZE - MEDIDA  
mm 30 x 60 x 200

**CUNEO MEDIO**  
**MEDIUM PLASTIC WEDGE**  
**CUÑA MEDIANA**

**MEDIUM**

CODICE  
CODE - CÓDIGO

**5150**



MISURA - SIZE - MEDIDA  
mm 25 x 75 x 200

**CUNEO GRANDE**  
**LARGE PLASTIC WEDGE**  
**CUÑA GRANDE**

**LARGE**

CODICE  
CODE - CÓDIGO

**5155**

**NEW**

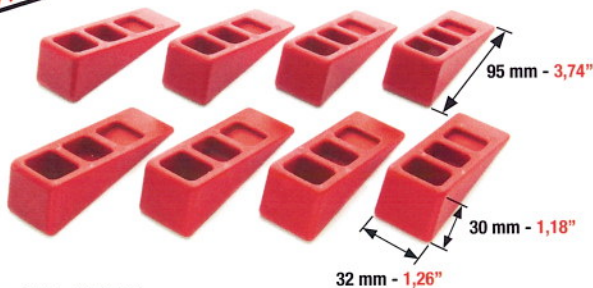

MISURA - SIZE - MEDIDA  
mm 30 x 32 x 95

**SET COMPOSTO DA 8 CUNEI MINI DI UGUALE MISURA**  
**SET OF 8 MINI WEDGES OF THE SAME SIZE**  
**JUEGO COMPUESTO POR 8 CUÑAS MINI DE IGUAL TAMAÑO**

**SET "0" (BABY)**

CODICE - CODE - CÓDIGO

**5132**

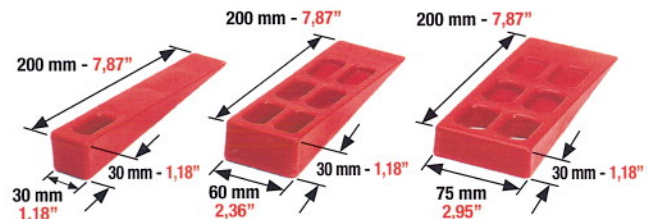

MISURE - SIZES - MEDIDAS  
mm 30 x 30 x 200  
mm 30 x 60 x 200  
mm 25 x 75 x 200

**SET COMPOSTO DA 3 CUNEI DI DIVERSA MISURA**  
**SET OF 3 WEDGES OF DIFFERENT SIZES**  
**JUEGO COMPUESTO POR 2 CUÑAS DE TAMAÑO GRANDE**

**SET "1" (STANDARD)**

CODICE - CODE - CÓDIGO

**5130**



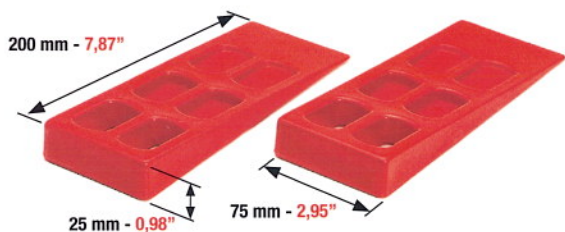

MISURE - SIZES - MEDIDAS  
mm 25 x 75 x 200

SET COMPOSTO DA 2 CUNEI DI MISURA GRANDE  
SET OF 2 LARGE WEDGES  
JUEGO COMPUESTO POR 2 CUÑAS DE TAMAÑO GRANDE

SET "2"

CODICE - CODE - CÓDIGO

5135

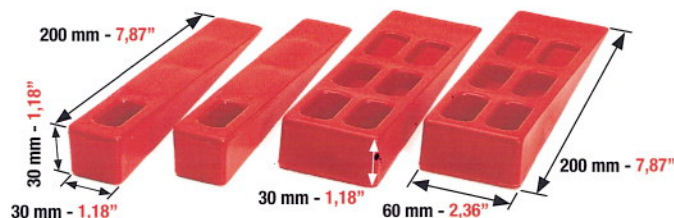

MISURE - SIZES - MEDIDAS  
mm 30 x 30 x 200  
mm 30 x 60 x 200

SET COMPOSTO DA 2 CUNEI PICCOLI + 2 MEDI  
SET OF 2 SMALL + 2 MEDIUM WEDGES  
JUEGO COMPUESTO POR 2 CUÑAS PEQUEÑAS + 2 MEDIAS

SET "3"

CODICE - CODE - CÓDIGO

5140



TOP QUALITY

STANDARD SIZE



SPATOLE IN PLASTICA PER INCHIOSTRO PER CALAMAI CON SENSORI "CPC"  
PLASTIC INK SPATULAS FOR "CPC" DUCT  
ESPATULAS DE PLASTICO PARA LA TINTA DE LOS TINTEROS CON SENSORES "CPC"

SCATOLE COMPOSTE DA 4 SPATOLE (GIALL ROSSO BLU NERO)  
BOXES CONTAIN 4 SPATULAS (YELLOW RED BLUE BLACK)  
CAJA CON 4 ESPATULAS (AMARILLO ROJO AZUL NEGRO)

CODICE  
CODE - CÓDIGO

5095

**PERSONALIZZARE LE SPATOLE**  
LE NOSTRE SPATOLE POSSONO  
ESSERE PRODOTTE CON IL VOSTRO  
MARCHIO COMMERCIALE  
STAMPATO SUL MANICO.  
(RICHIEDETE MAGGIORI INFORMAZIONI)

**PERSONALISE THE SPATULAS**  
OUR SPATULAS CAN BE PRODUCED  
WITH YOUR COMPANY NAME  
AND LOGO PRINTED ON THE HANDLE  
(ASK FOR MORE DETAILS)

**PERSONALIZAR  
LAS ESPATULAS**  
TODAS NUESTRAS ESPATULAS  
SE PUEDEN SUMINISTRAR  
CON SU MARCA COMERCIAL  
IMPRESA EN EL MANGO  
(SOLICITE MAYOR INFORMACION)





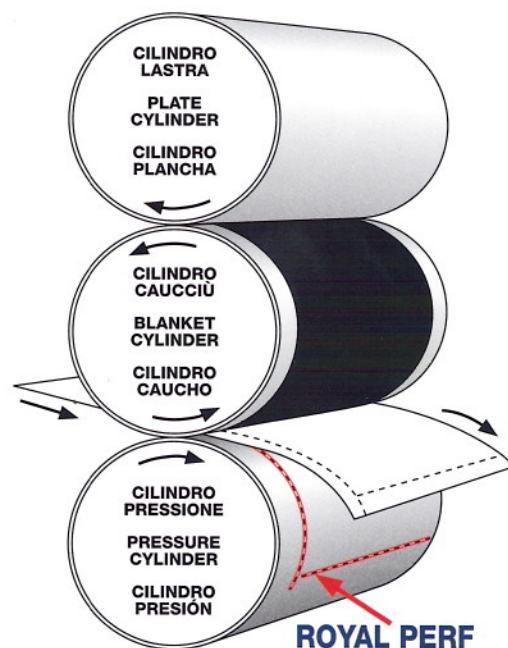

FILETTI PER FORARE CORDONARE FUSTELLARE IN OFFSET SIMULTANEI ALLA STAMPA  
RULES FOR PERFORATING, CREASING AND PUNCHING IN OFFSET SIMULTANEOUSLY TO PRINTING  
PERFILES PARA PERFORAR, HENDER Y TROQUELAR EN OFFSET SIMULTANEAMENTE A LA IMPRESIÓN

ALTA QUALITÀ - LUNGA DURATA / HIGH QUALITY - LONG LIFE / ALTA CALIDAD - LARGA DURACION



 I filetti perforatori “ROYAL PERF” vengono utilizzati in qualsiasi macchina da stampa offset o web offset di piccolo formato ogni qualvolta si desidera perforare, cordonare e tagliare simultaneamente al procedimento di stampa. I filetti “ROYAL PERF” garantiscono un’alta qualità di perforazione, taglio e cordonatura anche su lunghe tirature.

I filetti “ROYAL PERF” vengono proposti nella versione “centrale” e “laterale” in tutti i tipi di perforazione taglio o cordonatura per carta e per cartone.

 “ROYAL PERF” perforating rules are used in all small format offset and web presses whenever you need to perforate, crease and cut simultaneously to printing. “ROYAL PERF” rules guarantee high quality perforating, cutting and creasing also on long runs.

“ROYAL PERF” rules are offered in the “central” and “side” version for all types of perforating, cutting and creasing for paper and card.

 Los perfiles perforadores “ROYAL PERF” se pueden usar en cualquier maquina de imprimir de offset de pliegos o rotativas de offset en formato pequeño, en cualquier ocasión en la que se desee perforar, hender o cortar.

Simultaneamente con la impresión, los perfiles “ROYAL PERF” garantizan una “alta calidad” de perforacion, corte y hendido incluso en una tirada larga.

Los perfiles “ROYAL PERF” se presentan en la version “central” y “lateral”, en todos los tipos de perforacion, corte o hendido para papel y carton.



**FILETTI PER FORARE CORDONARE FUSTELLARE IN OFFSET SIMULTANEI ALLA STAMPA  
RULES FOR PERFORATING, CREASING AND PUNCHING IN OFFSET SIMULTANEOUSLY TO PRINTING  
PERFILES PARA PERFORAR, HENDER Y TROQUELAR EN OFFSET SIMULTANEAMENTE A LA IMPRESIÓN**



## ISTRUZIONI PER LA MESSA IN OPERA

- Pulire il cilindro di pressione da eventuali rimanenze di olio o di grasso.
- Fare una passata sul cilindro di pressione per determinare il posizionamento.
- Estrarre dalla scatola il filetto per la lunghezza necessaria, e togliere la strisciolina di carta che ne riveste il dorso.
- Applicare il filetto perforatore sul cilindro di pressione seguendo le linee di riferimento.
- Incollare una striscia di cellophan adesiva (inclusa nella scatola) sul filetto perforatore per l'intera lunghezza, fissandola bene sul cilindro.
- Controllare l'esito della perforazione prima di dar corso alla tiratura. Se la perforazione risultasse insufficiente si può rafforzare il filetto con un nastrino doppio-adesivo sottostante.
- In caso di perforazione eccessiva, applicare sopra il filetto una seconda o una terza striscia di cellophan adesiva in modo che i trattini non penetrino così profondamente sulla carta.



## INSTRUCTION FOR USE

- Clean the pressure cylinder of all residues of oil and grease.
- Pass the pressure cylinder to check its positioning.
- Extract the desired length of the rule from the box and remove the strip of paper that covers the back.
- Apply the perforating rule onto the pressure cylinder following the lines of reference.
- Stick a strip of adhesive cellophane (included in the box) onto the perforating rule to cover the entire length, fixing it firmly onto the cylinder.
- Check the result of the perforation before starting the run. If the perforation is not sufficient, you can reinforce the rule with a bi-adhesive strip underneath.
- If the perforation is excessive, apply on top of the rule a second and even a third strip of adhesive cellophane so that the teeth do not penetrate the paper so deeply.



## INSTRUCCIONES DE TRABAJO

- Limpiar el cilindro de presión de eventuales restos de aceite o grasa.
- Hacer una pasada sobre el cilindro de presión para determinar el posicionamiento.
- Sacar de la caja el perfil con la longitud precisa y separar la tira de papel que reviste el dorso.
- Aplicar el perfil perforador sobre el cilindro de presión siguiendo la línea de referencia.
- Pegar una tira de cinta adhesiva (incluida en la caja) sobre el perfil perforador a todo lo largo, fijándola bien sobre el cilindro.
- Controlar que perfore correctamente antes de proceder a la tirada. Si la perforación resulta insuficiente se puede reforzar el perfil con una cinta adhesiva a doble cara debajo.
- En caso de perforación excesiva, aplicar encima del perfil una segunda o tercera tira de cinta adhesiva, en tal modo de que los tramos perforadores no penetren profundamente en el papel.

## UNITÀ DI MISURA - MEASUREMENT SCALE - UNIDAD DE MEDIDA

### PERFORAZIONE - PERFORATION - PERFORACIÓN:

**CORDONATURA  
CREASING  
HENDIDO:**

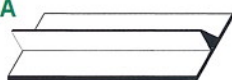

**TAGLIO  
CUTTING  
CORTE:**

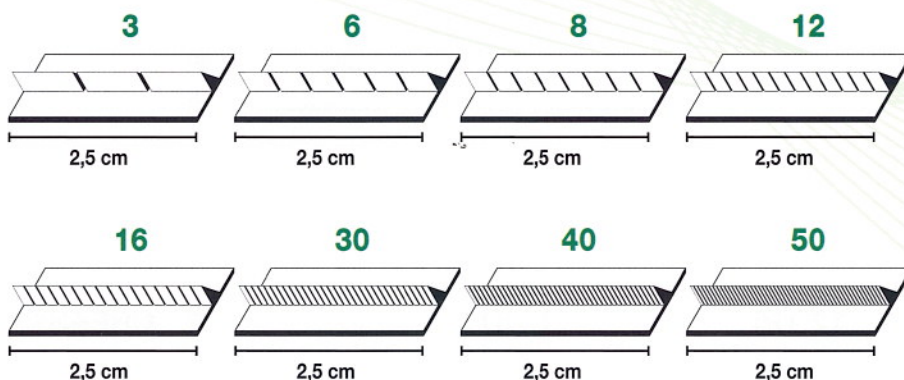
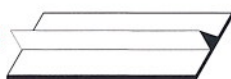



**SEMPRE IN STOCK  
ALWAYS IN STOCK  
SIEMPRE EN STOCK**



**CENTRALI - CENTRAL - CENTRALES**

3 TPI	COD. 2720090
6 TPI	COD. 2720091
8 TPI	COD. 2720092
12 TPI	COD. 2720093
16 TPI	COD. 2720094

**MICROPERF**

30 TPI	COD. 2720095
40 TPI	COD. 2720096
50 TPI	COD. 2720097
CREASING	COD. 2720098
CUTTING	COD. 2720099

**LATERALI - SIDE - LATERALES**

3 TPI	COD. 2720100
6 TPI	COD. 2720101
8 TPI	COD. 2720102
12 TPI	COD. 2720103
16 TPI	COD. 2720104

**MICROPERF**

30 TPI	COD. 2720105
40 TPI	COD. 2720106
50 TPI	COD. 2720107
CREASING	COD. 2720109
CUTTING	COD. 2720111



Copicalamaio per macchine  
Cubretinteros para maquinas  
Ink duct foils for

BREVETTATO

MANROLAND  
PATENTED

PATENTADO

# Perfecto!



CODE	MACHINE MODEL	SIZE A IN MM	SIZE D IN MM
18239	PRAKTICA 00 ONE-/TWO-COLOUR (NO SECTORS)	107	509
18240	PRAKTICA 00 TWO-COLOUR (WITH SECTORS)	150	509
18245	PRAKTICA 01		
18250	ROLAND FAVORIT (NO "CPC")	111	730
18255	ROLAND FAVORIT RVF (WITH "CPC")	104	717
18260	ROLAND 200 (NO "CPC")	127	730
18265	ROLAND 200 (WITH "CPC")	98	821
18270	ROLAND 300	147,5	719
18275	ROLAND 500	147,5	719
18280	ROLAND REKORD RZK (NO "CPC")	107	1029
18285	ROLAND REKORD/ROLAND 600 (WITH "CPC") <b>SPECIAL</b>	116	1016
18286	ROLAND REKORD RVK III B (WITH "CPC")	114	1020
18140	ROLAND 700 (ALL MODELS)	142	1020
18141	ROLAND 800 V° (92 X 132) <b>SPECIAL</b>	157	1326
18142	ROLAND 800 VI° (100 X 140)	157	1422
18144	ROLAND 800 VI° (100 X 140) <b>SPECIAL WITH "TGC" SYSTEM</b>	157	1400
18146	ROLAND 800 VII° (120 X 160)	157	1622
18150	ROLAND 900 / 5 (92 X 132)	220	1320
18151	ROLAND 900 / 6 (100 X 140)	220	1440
18154	ROLAND 900 XXL (120 X 160)	210	1620

I continui cicli di lavorazione e i frequenti cambi di inchiostro richiedono una costante attenzione del calamaio che deve risultare sempre ben pulito, privo di accumuli e residui di inchiostro essiccato. Tale attenzione comporta ripetute operazioni di lavaggio molto accurate e la rimozione di eventuali parti essiccate, da eseguire manualmente, ad ogni cambio di inchiostro.

Queste operazioni procurano notevoli tempi di fermo macchina incidendo fortemente sulla mancata produttività.

I copricalamaio "Perfecto"™ aiutano a ridurre notevolmente i tempi di inoperatività garantendo agli operatori maggior facilità, rapidità e flessibilità nei vari cicli produttivi.

Continuous work cycles and frequent ink changes require the constant attention of the ink duct, which must always be well cleaned, free of any accumulations or residues of dried ink. This attention necessitates repeated and careful wash operations and the removal of any dried dirt, which has to be done manually every time you change the ink.

These cleaning operations cause considerable downtimes which significantly reduce the productivity of the press.

The "Perfecto"™ duct foils help to considerably shorten the periods of non-productivity, guaranteeing the operators a greater ease, speed and flexibility in the various production cycles.

Los continuos ciclos de trabajo y los frecuentes cambios de tinta precisan de una constante atención sobre el tintero, que debe estar siempre limpio sin que hayan acumulados residuos de tinta seca.

Esta atención comporta repetidas operaciones de lavado muy a fondo para eliminar los eventuales residuos secos, haciéndolo manualmente, en cada cambio de tinta. Estas operaciones provocan notables tiempos de paradas de máquina, incidiendo fuertemente sobre la falta de productividad.

Los cubretinteros "Perfecto"™ ayudan a reducir notablemente los tiempos de parada de máquina, garantizando al operario una mayor facilidad, rapidez y flexibilidad en los varios ciclos productivos.

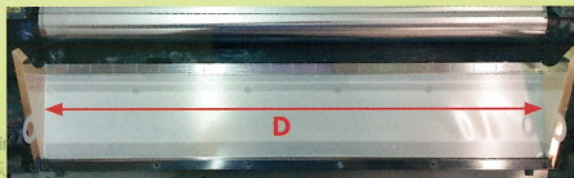
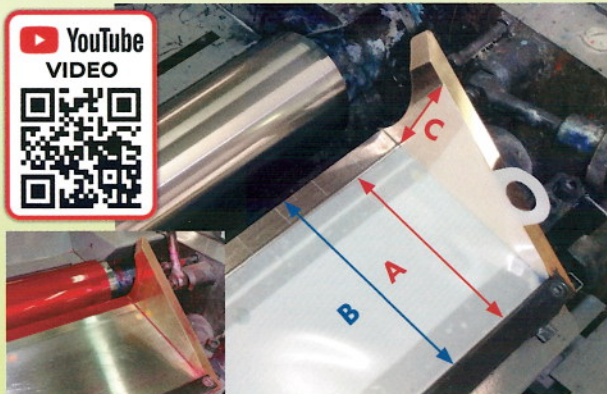



BREVETTATO . PATENTED . PATENTADO

# Perfecto!

SCHEDA PER REALIZZAZIONE NUOVI MODELLI  
FORM FOR THE MANUFACTURE OF NEW MODELS  
FICHA PARA LA REALIZACION DE NUEVOS MODELOS

## MACHINE:

### SIZES

\*\*A: mm \_\_\_\_\_  
(WIDTH OF INK DUCT,  
SECTORS EXCLUDED)

B: mm \_\_\_\_\_  
(WIDTH OF INK DUCT,  
SECTORS INCLUDED)

C: mm \_\_\_\_\_

\*\*D: mm \_\_\_\_\_

\*\* MOST IMPORTANT

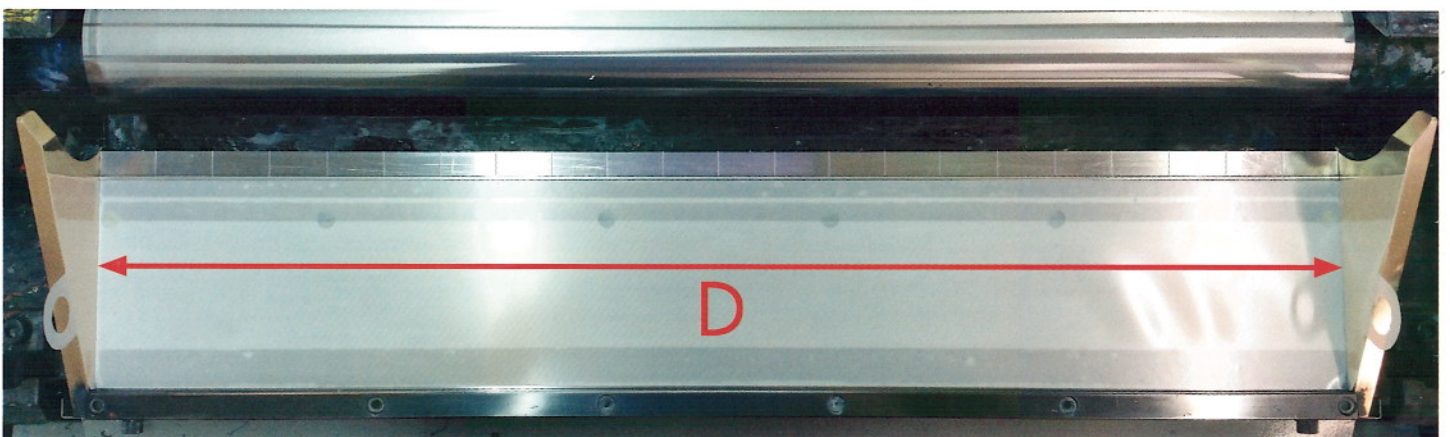
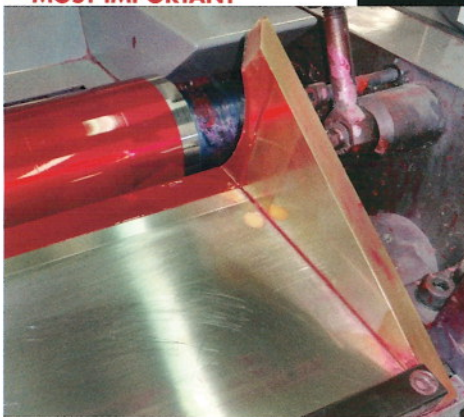
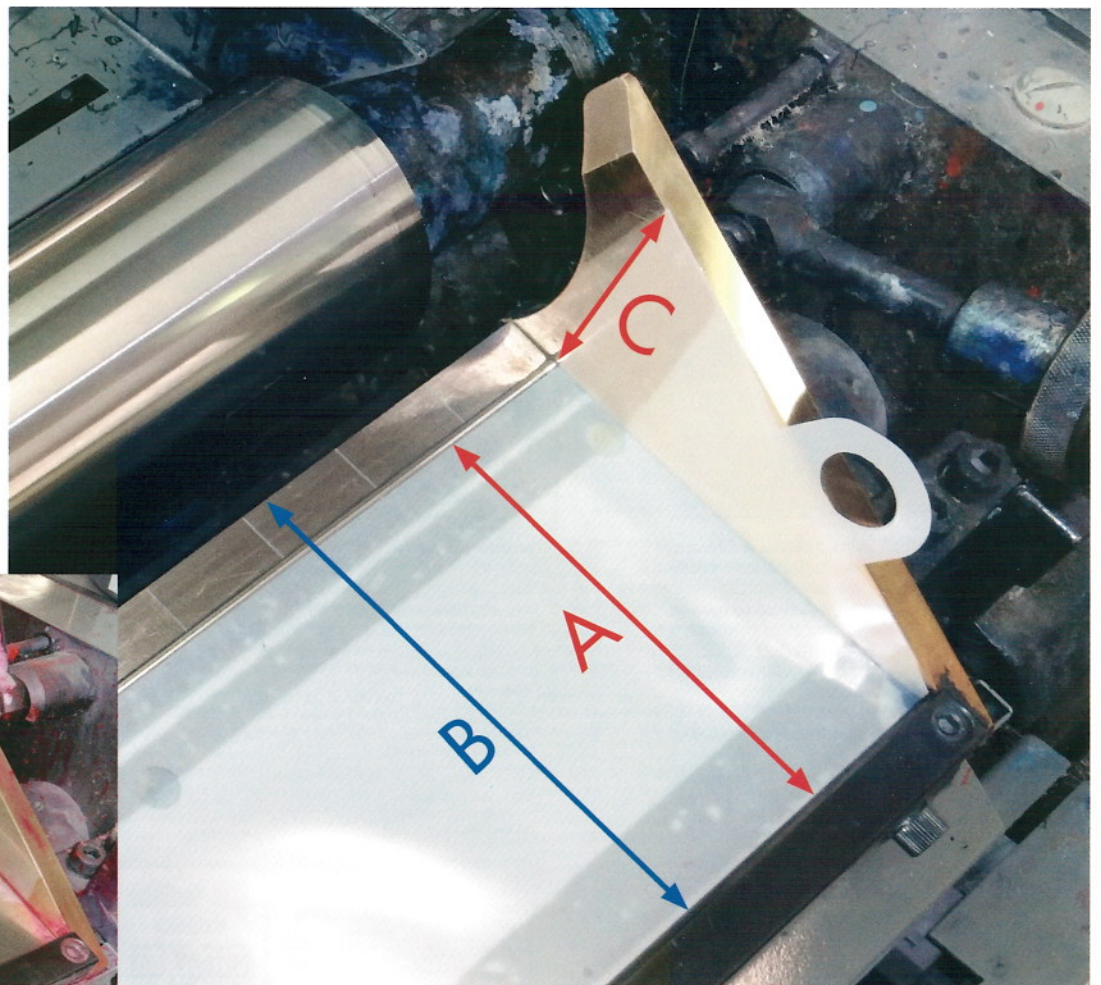



# FOILTEX® WASHCLOTH PRODUCTS FOR MANUAL CLEANING



CODE 27.22384 **FOILTEX® BLU-TEX STANDARD VERSION\*** (68gr/sqm)  
 CODE 27.22384A **FOILTEX® BLU-TEX MARINE STANDARD VERSION\*** (68gr/sqm)

CODE 27.22382 **FOILTEX® WHITE-TEX VERSION** (68gr/sqm)  
 CODE 27.22386 **FOILTEX® SONTARA VERSION** (68gr/sqm)

**1 BOX = 500 CLOTHS**  
**CLOTH SIZE: 400MM X 310MM | \* STANDARD = MOST FREQUENTLY SOLD**



CODE 27.22384B **FOILTEX® BLU-TEX MAXI VERSION** (68gr/sqm)  
 CODE 27.22384C **FOILTEX® BLU-TEX MARINE MAXI VERSION** (68gr/sqm)

**1 BOX = 625 CLOTHS**  
**CLOTH SIZE: 400MM X 500MM**



CODE 27.22386A **FOILTEX® RAINBOW STANDARD VERSION** (68gr/sqm)

**1 BOX = 500 CLOTHS MULTICOLOR**  
**CLOTH SIZE: 400MM X 310MM**



CODE 27.22389 **FOILTEX® WHITE-TEX KING STANDARD VERSION**  
 (100gr/sqm)

**1 BOX = 400 CLOTHS**  
**CLOTH SIZE: 400MM X 310MM**



CODE 27.22383 **FOILTEX® PERFECTING STANDARD VERSION**  
 SPECIFIC WASHCLOTH FOR MANUAL CLEANING OF SURFACES WITH ANTI-MARKING TREATMENT

**1 BOX = 250 CLOTHS**  
**CLOTH SIZE: 400MM X 310MM**



CODE 27.22381 **ALL-TEX® UNIVERSAL STANDARD VERSION**  
 MICRO-PERFORATED CLOTH FOR MANUAL CLEANING OF EVERY KIND OF SURFACES

**1 BOX = 300 CLOTHS**  
**CLOTH SIZE: 400MM X 310MM**



CODE 27.22385 **SUPERTEX MINI-ROLLS**  
 FOR MANUAL CLEANING

**N. 650 TEAR-OFF CLOTHS**  
**CLOTH SIZE: 400MM X 280MM**

CODE 27.22388 **SUPERTEX MINI-ROLLS**  
 FOR MANUAL CLEANING

**NO TEAR-OFFS ON ROLL**  
**ROLL SIZE: 230-260MM X 500MT**  
 (The roll width may vary from 230-260mm depending on availability)

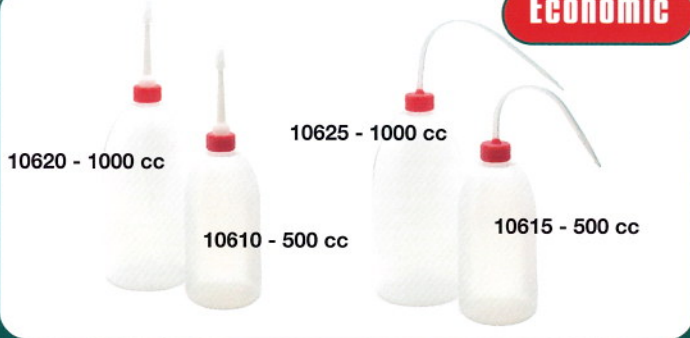

**Economic**

10620 - 1000 cc

10625 - 1000 cc

10610 - 500 cc

10615 - 500 cc

BOTTIGLIE DI LAVAGGIO ECONOMICHE  
CON BECCUCCIO DIRITTO O CURVO DA 500 E 1000 CC

ECONOMICAL WASH BOTTLES  
WITH STRAIGHT OR BENT SPOUT - 500 CC AND 1000 CC

BOTELLA DE LAVADO ECONOMICA  
CON TUBO RECTO O CURVADO DE 500 Y 1000 CC

CODICE - CODE - CÓDIGO

10610 / 10615

10620 / 10625

**Top Quality**

BOTTIGLIE DI LAVAGGIO DI ALTA QUALITÀ E RESISTENZA  
AI VARI SOLVENTI - 1000 CC

HIGH QUALITY SOLVENT-RESISTANT WASH BOTTLES - 1000 CC

BOTELLA DE LAVADO DE ALTA CALIDAD Y RESISTENCIA  
A SOLVENTES VARIOS DE 1000 CC

CODICE - CODE - CÓDIGO

10600

ESCLUSIVA MONDIALE  
WORLDWIDE EXCLUSIVE  
EXCLUSIVA MONDIAL



CONFEZIONE DA 12 PEZZI  
PACKET OF 12 PCS  
CONFECCION DE 12 UNIDADES



## SUPER GLOVES PROFESSIONAL

GUANTI SPECIALI IN NITRILE DI ALTISSIMA QUALITÀ RESISTENTI AGLI ACIDI ED AI SOLVENTI

SPECIAL HIGH QUALITY NITRILE GLOVES RESISTANT TO ACIDS AND SOLVENTS

GUANTES ESPECIALES DE NITRILLO DE ALTISSIMA CALIDAD, RESISTENTES A LOS ACIDOS Y SOLVENTES

CODICE CODE - CÓDIGO	MISURA - SIZE - MEDIDA
10660	8
10662	9
10664	10

TOP QUALITY  
ORIGINAL



## ROYAL SPONGES

SPUGNE PRESSATE DI ALTISSIMA QUALITÀ

TOP QUALITY COMPRESSED SPONGES

ESPONJAS PRENSADA DE ALTISSIMA CALIDAD

CONFEZIONE DA 10 PEZZI PACKET OF 10 PCS CONFECCION DE 10 UNIDADES	DIMENSIONI - SIZE - TAMAÑO	CODICE - CODE - CÓDIGO
	140 x 95 x 35 mm	10651
	140 x 95 x 32 mm	10652

## SUPER SCRUBBER

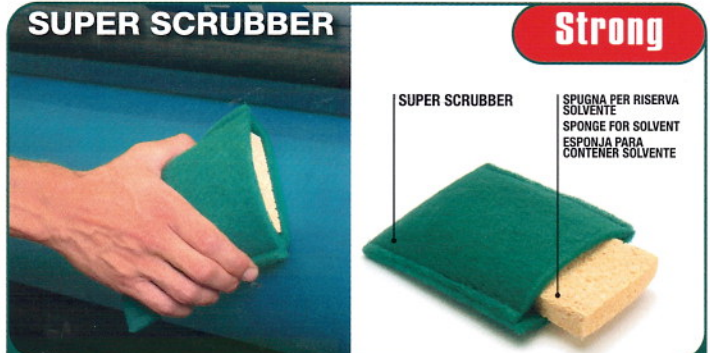
**Strong**

FIBRA ABRASIVA SPECIALE PER LA PULIZIA IN PROFONDITÀ DI TESSUTI GOMMATI MOLTO SPORCHI COMPLETA DI SPUGNA PER IL SOLVENTE

SPECIAL ABRASIVE FIBRE FOR DEEP CLEANING OF VERY DIRTY PRINTING BLANKETS, COMPLETE WITH SPONGE FOR SOLVENT

FIBRA ABRASIVA ESPECIAL PARA LA LIMPIEZA EN PROFUNDIDAD DE CAUCHOS MUY SUCIOS, CON ESPONJA PARA EL SOLVENTE

ORDINE MINIMO 4 PEZZI  
MINIMUM ORDER 4 PCS  
PEDIDO MINIMO 4 PIEZAS

CODICE - CODE - CÓDIGO

10640



**SUPER SCRUBBER**  
*white*



**Soft**



SUPER SCRUBBER *white*

SPUGNA PER RISERVA SOLVENTE  
SPONGE FOR SOLVENT  
ESPONJA PARA CONTENEDOR SOLVENTE

SPECIALE FIBRA SINTETICA NON ABRASIVA PER LA PULIZIA OTTIMALE DI TESSUTI GOMMATI MOLTO SPORCHI COMPLETA DI SPUGNA PER IL SOLVENTE  
SPECIAL SYNTHETIC NON-ABRASIVE FIBRE FOR THOROUGH CLEANING OF VERY DIRTY PRINTING BLANKETS, COMPLETE WITH SPONGE FOR SOLVENT  
FIBRA SINTETICA ESPECIAL NO ABRASIVA PARA LA PERFECTA LIMPIEZA DE CAUCHOS MUY SUCIOS, CON ESPONJA PARA EL SOLVENTE

ORDINE MINIMO 4 PEZZI MINIMUM ORDER 4 PCS PEDIDO MINIMO 4 PIEZAS	CODICE - CODE - CÓDIGO
	<b>10644</b>

**DUAL SUPER SCRUBBER**



**NEW** **1/2 Strong**  
**1/2 Soft**



SUPER SCRUBBER SOFT

SUPER SCRUBBER STRONG

SPUGNA PER RISERVA SOLVENTE  
SPONGE FOR SOLVENT  
ESPONJA PARA CONTENEDOR SOLVENTE

FIBRA ABRASIVA (STRONG) E SPECIALE FIBRA SINTETICA NON ABRASIVA (SOFT) PER PULIZIA OTTIMALE DI TESSUTI GOMMATI MOLTO SPORCHI COMPLETA DI SPUGNA PER IL SOLVENTE  
ABRASIVE FIBRE (STRONG) AND SPECIAL SYNTHETIC NON-ABRASIVE FIBRE (SOFT) FOR THOROUGH CLEANING OF VERY DIRTY PRINTING BLANKETS COMPLETE WITH SPONGE FOR SOLVENT  
FIBRA ABRASIVA (STRONG) Y FIBRA SINTETICA ESPECIAL NO ABRASIVA (SOFT) PARA LA PERFECTA LIMPIEZA DE CAUCHOS MUY SUCIOS CON ESPONJA PARA EL SOLVENTE

ORDINE MINIMO 4 PEZZI MINIMUM ORDER 4 PCS PEDIDO MINIMO 4 PIEZAS	CODICE - CODE - CÓDIGO
	<b>10640-A</b>

**COMPACT SCRUB**



**Strong**



FIBRA ABRASIVA SPECIALE PER LA PULIZIA IN PROFONDITÀ DI TESSUTI GOMMATI MOLTO SPORCHI  
SPECIAL ABRASIVE FIBRE FOR DEEP CLEANING OF VERY DIRTY PRINTING BLANKETS  
FIBRA ABRASIVA ESPECIAL PARA LA LIMPIEZA EN PROFUNDIDAD DE CAUCHOS MUY SUCIOS

ORDINE MINIMO 4 PEZZI MINIMUM ORDER 4 PCS PEDIDO MINIMO 4 PIEZAS	CODICE - CODE - CÓDIGO
	<b>10642</b>

**COMPACT SCRUB**  
*white*



**Soft**



SPECIALE FIBRA SINTETICA NON ABRASIVA PER LA PULIZIA OTTIMALE DI TESSUTI GOMMATI MOLTO SPORCHI  
SPECIAL SYNTHETIC NON-ABRASIVE FIBRE FOR THOROUGH CLEANING OF VERY DIRTY PRINTING BLANKETS  
FIBRA SINTETICA ESPECIAL NO ABRASIVA PARA LA PERFECTA LIMPIEZA DE CAUCHOS MUY SUCIOS

ORDINE MINIMO 4 PEZZI MINIMUM ORDER 4 PCS PEDIDO MINIMO 4 PIEZAS	CODICE - CODE - CÓDIGO
	<b>10646</b>

**DUAL COMPACT SCRUB**



**1/2 Strong**  
**1/2 Soft**

**NEW**



SUPER SCRUBBER SOFT

SUPER SCRUBBER STRONG

FIBRA ABRASIVA (STRONG) E SPECIALE FIBRA SINTETICA NON ABRASIVA (SOFT) PER PULIZIA OTTIMALE DI TESSUTI GOMMATI MOLTO SPORCHI  
ABRASIVE FIBRE (STRONG) AND SPECIAL SYNTHETIC NON-ABRASIVE FIBRE (SOFT) FOR THOROUGH CLEANING OF VERY DIRTY PRINTING BLANKETS  
FIBRA ABRASIVA (STRONG) Y FIBRA SINTETICA ESPECIAL NO ABRASIVA (SOFT) PARA LA PERFECTA LIMPIEZA DE CAUCHOS MUY SUCIOS

ORDINE MINIMO 4 PEZZI MINIMUM ORDER 4 PCS PEDIDO MINIMO 4 PIEZAS	CODICE - CODE - CÓDIGO
	<b>10646-A</b>

**SIMPLE SCRUBBER**



**Strong**



29 mm - 1,14"

120 mm - 4,72"

90 mm - 3,54"

SPECIALE SPUGNA REALIZZATA DA UN LATO CON UNA FIBRA SINTETICA ABRASIVA E DA UN LATO CON VERA SPUGNA IN CELLULOSA. SPECIFICA PER LA PULIZIA IN PROFONDITA' DI TESSUTI GOMMATI MOLTO SPORCHI.  
SPECIAL SPONGE MADE ON ONE SIDE WITH SYNTHETIC ABRASIVE FIBRE AND ON THE OTHER WITH REAL SPONGE IN CELLULOSE. SPECIFIC FOR DEEP CLEANING OF VERY DIRTY PRINTING BLANKETS.  
ESPONJA ESPECIAL REALIZADA DE UN LATO CON FIBRA SINTETICA ABRASIVA Y DEL OTRO CON ESPONJA VERDADERA EN CELLULOSA. ESPECIFICA PARA LA LIMPIEZA EN PROFUNDIDAD DE CAUCHOS MUY SUCIOS.

ORDINE MINIMO 4 PEZZI MINIMUM ORDER 4 PCS PEDIDO MINIMO 4 PIEZAS	CODICE - CODE - CÓDIGO
	<b>10647</b>



**Special**



TAMPONI SVILUPPO LASTRE  
PLATE DEVELOPER BUFFER  
BUFFER DESARROLLADOR DE PLACAS

ORDINE MINIMO 2 PEZZI  
MINIMUM ORDER 2 PCS  
PEDIDO MINIMO 2 PIEZAS

CODICE - CODE - CÓDIGO

**2722374**



**100% MADE IN ITALY**

PASTA LAVAMANI CON ABRASIVI NATURALI - 5000 ML/BARATTOLO  
HAND CLEANING PASTE WITH NATURAL SCRUBBING AGENT- 5000 ML/PAIL  
PASTA LAVAMANOS CON ABRASIVOS NATURALES - 5000 ML/FRASCO

ORDINE MINIMO - MINIMUM  
ORDER - PEDIDO MINIMO:  
**1 BOX = 4 PAILS**

CODICE - CODE - CÓDIGO

**2720220**



# ALL-TEX UNIVERSAL

**THE NEW MICRO-PERFORATED CLOTH  
FOR THE CLEANING OF ALL SURFACES !!**

**IL NUOVO PANNO MICROFORATO  
PER LA PULIZIA DI TUTTE LE SUPERFICI !!**

**CODE 27.22381**  
**ALL-TEX® UNIVERSAL**  
**BOX = 300 CLOTHS**  
**CLOTH SIZE: 400MM X 310MM**





# folex<sup>®</sup>

# PACK FOIL

 **FILM POLIESTERE DA UTILIZZARE NEI CILINDRI PORTA LASTRE E PORTA CAUCCIÙ PER IL RAGGIUNGIMENTO OTTIMALE DEL "PACK" NELLE MACCHINE DA SPAMPA.**

 **POLYESTER FOIL FOR PLATE AND BLANKET CYLINDERS TO OBTAIN OPTIMUM "PACK" ON THE PRINTING PRESS.**

 **FILM DE POLIESTER PARA UTILIZAR EN LOS CILINDROS PORTAPLANCHA Y PORTACAUCHOS, PARA CONSEGUIR UNA OPTIMA MANTILLA "PACK" EN LA MAQUINA DE IMPRIMIR.**

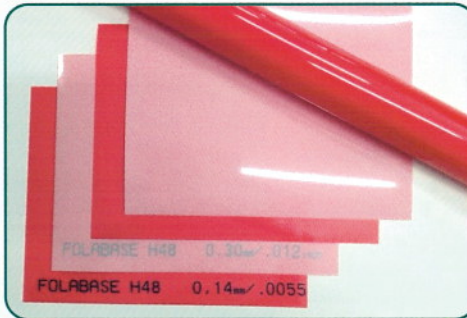

**SPESSORI  
THICKNESSES  
ESPEORES**

**PACK-FOIL ADESIVO - PACK-FOIL ADHESIVE - PACK-FOIL ADHESIVO (FOLEX H 48)**

mm 0,08 - 0,10 - 0,12 - 0,14 - 0,16 - 0,18 - 0,20 - 0,21 - 0,22 - 0,23 - 0,24 - 0,25 - 0,26 - 0,28 - 0,30 - 0,32 - 0,35 - 0,40 - 0,45 - 0,50

**PACK-FOIL NON ADESIVO - PACK-FOIL NON-ADHESIVE - PACK-FOIL NO ADHESIVO (FOLABASE "U")**

mm 0,10 - 0,12 - 0,14 - 0,16 - 0,18 - 0,20 - 0,23 - 0,25 - 0,28 - 0,30 - 0,35

**PACK-FOIL PUÒ ESSERE FORNITO IN ROTOLO O IN QUALSIASI FORMATO RICHIESTO  
PACK-FOIL CAN BE SUPPLIED IN ROLLS OR IN ANY SIZE OF CUT SHEETS YOU WISH TO REQUEST  
BAJO PEDIDO PODEMOS SUMINISTRAR EL PACK-FOIL EN ROLLOS O CORTADO EN CUALQUIER FORMATO**





# PERFECT BLADES®

RACLE DI LAVAGGIO PER RULLI INCHIOSTRATORI  
WASH-UP BLADES FOR INK ROLLERS  
REGLETAS DE LAVADO PARA RODILLOS ENTINTADORES

**MR** = metal and rubber

**MRE** = metal and rubber "EPDM"

**P** = plastic

**R** = rubber

**V** = vulcollan for "UV INKS" 

top quality rubber for traditional inks

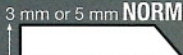
**T** = teflon for "UV INKS" 

**ST** = shaped teflon for "UV INKS"

The Number One



**PVC**

**SP** = special plastic

**FA** = laminated fibre and aluminium

**RA** = rubber and aluminium

**MRA** = metal and rubber coupled

**F** = laminated fibre



MATERIALE MATERIAL MATERIAL	SPESSORE - SEZIONE THICKNESS - SECTION ESPOSOR - SECCION	★★★ OTTIMO/EXCELLENTE/EXCELENTE ★★ MOLTO BUONO/VERY GOOD/MUY BIEN ★ BUONO/GOOD/BIEN	APPLICAZIONE APPLICATION APLICACION
<b>MR</b> METAL AND RUBBER		★★★	TRADITIONAL INKS
		★★	HYBRID INKS
		★	UV - H-UV - LED INKS
<b>MRE</b> METAL AND RUBBER  NBR + EPDM		★★★	TRADITIONAL INKS
		★★	HYBRID INKS
		★	UV - H-UV - LED INKS
<b>R</b> RUBBER		★★★	TRADITIONAL INKS
		★★	HYBRID INKS
		★	UV - H-UV - LED INKS
<b>P</b> PLASTIC		★★★	TRADITIONAL INKS
		★	UV - H-UV - LED INKS
<b>SP</b> SPECIAL PLASTIC		★★	HYBRID INKS
<b>P</b> PLASTIC		★★	TRADITIONAL INKS
		★★★	HYBRID INKS
<b>SP</b> SPECIAL PLASTIC		★	UV - H-UV - LED INKS
<b>P</b> PLASTIC		★★	UV - H-UV - LED INKS
		★★★	HYBRID INKS
<b>SP</b> SPECIAL PLASTIC		★	TRADITIONAL INKS
<b>T</b> TEFLON (NORMAL)		★★★	UV - H-UV - LED INKS
		★★★	HYBRID INKS
<b>ST</b> SHAPED TEFLON		★★★	UV - H-UV - LED INKS
		★★★	HYBRID INKS
		★★★	TRADITIONAL INKS
<b>V</b> VULCOLLAN		★★★	TRADITIONAL INKS
		★★★	HYBRID INKS
		★★★	UV - H-UV - LED INKS



**PIÙ DI 3000 DIVERSI TIPI  
DI RACLE DI LAVAGGIO!!  
MORE THAN 3000 DIFFERENT TYPES  
OF WASH-UP BLADES!!  
¡¡MAS DE 3000 TIPOS DIVERSOS  
DE REGLETAS DE LAVADO!!**



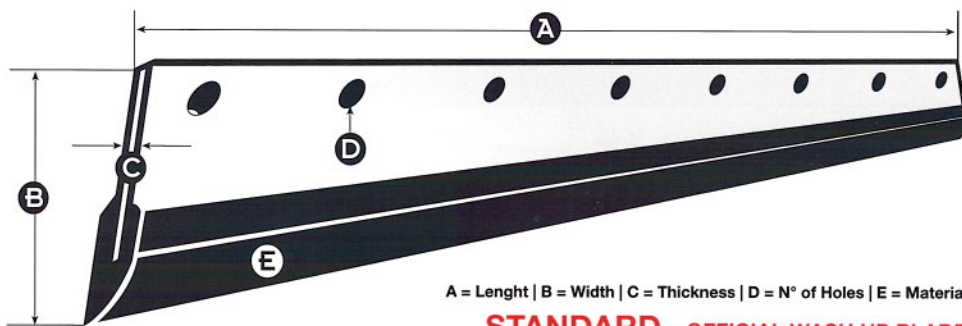

A = Length | B = Width | C = Thickness | D = N° of Holes | E = Material

**STANDARD = OFFICIAL WASH UP BLADE**

RACLE LAVARULLI PIÙ RICHIESTE - THE MOST POPULAR WASH-UP BLADES - REGLLETAS LAVA-RODILLOS MAS SOLICITADAS

**NB: MRE = MR +15% PRICE**

## MANROLAND

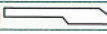
CODICE CODE CODIGO	MACCHINA E MODELLO - MACHINE & MODEL - MÁQUINA Y MODELO	A	B	C	D	E
		MM	MM	MM		
365	PRAKTICA - 00 (Numbering group)	520	38	0,5	11	MR
370	PRAKTICA - 00 (Special-Numbering group-folded)	520	68	0,5	9+4	MR
360	PRAKTICA - 00 (STANDARD)	555	68	0,5	6	MR
361	ROLAND 50 (Slots)	590	60	0,5	6	MR
362	ROLAND 50 (Slots) PLASTIC	590	60	1	6	P
366	ROLAND 50 TYPE R55-00 PLASTIC	610	60	1	6	P
380	PRAKTICA - 01 (Numbering group)	670	38	0,5	14	MR
382	PRAKTICA - 01 (Numbering group-folded)	670	64	0,5	6	MR
375	PRAKTICA - 01	705	68	0,5	7	MR
385	ROLAND 100 (STANDARD)	706	65	0,5	7	MR
390	ROLAND 100 SPECIAL	715	65	0,5	9	MR
410	ROLAND FAVORIT - RF - 01	720	65	0,5	8	MR
395	ROLAND 200 (OLD MODEL) (STANDARD)	785	65	0,5	8	MR
402	ROLAND 200 (NEW MODEL) SPECIAL PLASTIC	790	60	1	8	SP
403	ROLAND 200 (NEW MODEL)	790	60	0,5	8	MR
400	ROLAND 200 (NEW MODEL) (STANDARD)	800	65	0,5	8	MR
415	ROLAND FAVORIT - RF - OB/RF - 02 (STANDARD)	800	65	0,5	8	MR
420	ROLAND COLORMETAL PERLE	810	60	0,5	0	MR
421	ROLAND COLORMETAL PERLE	810	60	2	0	P
405	ROLAND 300/305 (STANDARD) SPECIAL PLASTIC (Holes)	817	60	1	8	SP
405B	ROLAND 300/305 (STANDARD) SPECIAL PLASTIC (Slots)	817	60	1	8	SP
405A	ROLAND 300 SPECIAL PLASTIC	817	40	1	0	SP
406	ROLAND 300	817	60	3	8	R
407	ROLAND 300	817	60	0,5	8	MR
408	ROLAND 500 SPECIAL PLASTIC	820	60	1	8	SP
408A	ROLAND 500	820	60	0,5	8	MR
408B	ROLAND 500 (For "UV" inks) VULCOLLAN	820	60	5	8	V
409	ROLAND 500 (NEW MODEL) / ROLAND 200E (NEW MODEL) SPECIAL PLASTIC	820	40	1	0	SP
409A	ROLAND 500 (NEW MODEL) / ROLAND 200E (NEW MODEL) VULCOLLAN	820	40	5	0	V
411	ROLAND 200 SPECIAL PLASTIC	827	40	1	0	SP
425	ROLAND/MILLER	840	102	0,5	5	MR
430	ROLAND - PARVA I - PR1	900	65	0,5	9	MR
435	ROLAND - PARVA II - PR/RZP II	920	65	0,5	10	MR
440	ROLAND - PARVA II - C (RP II C)	995	65	0,5	10	MR
445	ROLAND REKORD III	1042	65	0,5	11	MR
456	ROLAND REKORD - RZK III B (AUTOWASH)	1055	26	0,5	11	MR
558	ULTRA M.A.N.	1060	37	5	0	R
450	ROLAND REKORD - RVK III B	1075	65	0,5	11	MR
465	ROLAND 600 (Macinazione superiore/Upper grinding/Cuerpo superior)	1090	65	0,5	11	MR
475	ROLAND 700 (OLD MODEL)	1093	58	0,5	11	MR
470	ROLAND 600 (Macinazione inferiore/Lower grinding/Cuerpo Inferior)	1100	65	0,5	11	MR
455	ROLAND REKORD - RZK III B (STANDARD)	1100	65	0,5	11	MR
480	ROLAND 700 (NEW MODEL) (STANDARD)	1100	53	0,5	13	MR
481	ROLAND 700 (For "UV" inks) SPECIAL PLASTIC	1100	55	3	13	SP
482	ROLAND 700 (For "UV" inks) SPECIAL PLASTIC	1100	55	1	13	SP
483C	ROLAND 700 (For "UV" inks) TEFLON	1100	55	3	13	T
483	ROLAND 700 (For "UV" inks) SHAPED TEFLON  HERCULES BLADE	1100	55	5/3	13	ST
483B	ROLAND 700 (For "UV" inks) VULCOLLAN	1100	55	5	13	V
483A	ROLAND 700 (NEW VERSION)	1100	40	0,5	0	MR
483E	ROLAND 700 SPECIAL PLASTIC	1102	49	1	11	SP
483F	ROLAND 700 SPECIAL PLASTIC	1102	52	1	11	SP
483G	ROLAND 700 SPECIAL PLASTIC	1102	49	2	11	SP
483H	ROLAND 700 SPECIAL PLASTIC	1102	52	2	11	SP
483J	ROLAND 700 TEFLON	1102	49	2	11	T



CODICE CODE CODIGO	MACCHINA E MODELLO - MACHINE & MODEL - MÁQUINA Y MODELO	A	B	C	D	E
		MM	MM	MM		
483K	ROLAND 700 TEFLON	1102	52	2	11	T
483D	ROLAND 700 (NEW MODEL)	1105	40	0,5	0	MR
484	ROLAND 700 (NEW MODEL) SPECIAL PLASTIC	1108	40	1	0	SP
486	ROLAND 700 (NEW MODEL) (For "UV" inks) SPECIAL PLASTIC	1108	40	3	0	SP
487	ROLAND 700 (NEW MODEL) (For "UV" inks) SHAPED TEFLON  HERCULES BLADE	1108	40	5/3	0	ST
487A	ROLAND 700 (NEW MODEL) (For "UV" inks) TEFLON	1108	40	3	0	T
487B	ROLAND 700 (NEW MODEL) (For "UV" inks) VULCOLLAN	1108	40	5	0	V
487C	ROLAND 700 (NEW MODEL) EPDM	1108	40	0,5	0	MRE
460	ROLAND REKORD - RWK III B	1132	65	0,5	12	MR
485	ROLAND ULTRA IV° 1 MODEL	1145	65	0,5	11	MR
533	M.A.N.	1156	65	0,5	6	MR
490	ROLAND ULTRA IV° 2 MODEL	1195	65	0,5	11	MR
526	ROLAND 900/4 SPECIAL PLASTIC	1230	60	1	14	SP
526A	ROLAND 900/4 (NEW VERSION) (For "UV" inks) VULCOLLAN	1230	60	5	14	V
532	M.A.N. 5 - GS	1280	78	0,5	14	MR
495	ROLAND ULTRA V° - W	1335	65	0,5	13	MR
496	ROLAND ULTRA V°	1355	65	0,5	13	MR
560	ULTRA M.A.N.	1400	30	5	0	R
527A	ROLAND 900/5 SPECIAL PLASTIC	1404	40	1	0	SP
500	ROLAND 800 V° - 800 V° W	1410	65	0,5	13	MR
502	ROLAND SPRINT - LTG (LITOLATTA/TIN LITHOGRAPHIC PRESSES/METALGRAFICA) SPECIAL PLASTIC	1410	60	2	14	SP
527	ROLAND 900/5 SPECIAL PLASTIC	1410	60	1	14	SP
527B	ROLAND 900/5	1410	60	0,5	14	MR
527C	ROLAND 900/5 (For "UV" inks) VULCOLLAN	1410	60	5	14	V
535	M.A.N. GS 140	1436	78	0,5	15	MR
629A	MAN	1468	64	0,5	9	MR
505	ROLAND ULTRA VI° (STANDARD)	1475	65	0,5	14	MR
567	M.A.N.	1500	25	5	0	R
510	ROLAND 800 VI° (STANDARD)	1510	65	0,5	14	MR
511	ROLAND 900/6 PLASTIC	1522	40	1	0	P
536A	ROLAND 904 LU - 6 SPECIAL PLASTIC	1524	40	1	0	SP
536B	ROLAND 904 LU - 6	1524	40	0,5	0	MR
530	ROLAND 900/6 - 900 XL (STANDARD) SPECIAL PLASTIC	1530	60	1	16	SP
534	ROLAND 900/6 (For "UV" and bivalent inks) SPECIAL PLASTIC	1530	60	2	16	SP
536	ROLAND 900/6 (For "UV" and bivalent inks) SPECIAL PLASTIC	1530	60	3	16	SP
531	ROLAND 900	1530	60	0,5	16	MR
531A	ROLAND 900 (For "UV" inks) VULCOLLAN	1530	60	5	16	V
531B	M.A.N.	1530	64	0,5	15	MR
540	M.A.N. G 140	1540	60	0,5	12	MR
542	M.A.N. GS 140	1550	78	0,5	16	MR
570	LITHO - M.A.N.	1552	65	0,5	16	MR
572	ULTRA - M.A.N. VI°	1557	53	0,5	12	MR
573	M.A.N.	1560	64	0,5	8	MR
574	M.A.N.	1590	64	0,5	10+4	MR
571	ULTRA - M.A.N.	1593	64	0,5	17	MR
545	M.A.N. GS 160	1614	78	0,5	17	MR
515	ROLAND ULTRA VII° - ULTRA VII° B	1675	65	0,5	16	MR
575	LITHO - M.A.N.	1700	65	0,5	16	MR
520	ROLAND ULTRA VII° - VII° B - 802 - 804 - 806 V - 842	1710	65	0,05	16	MR
524	ROLAND 800 VULCOLLAN	1710	60	3	0	V
525	ROLAND 800 VII° - VIII° B	1710	65	0,5	16	MR
525A	ROLAND MAN	1720	64	0,5	18	MR
528	ROLAND 900 XXL7/7B - PLUS SPECIAL PLASTIC	1730	40	1	0	SP
528A	ROLAND 900 XXL7/7B - PLUS	1730	40	0,5	0	MR
577	ROLAND - M.A.N.	1730	65	0,5	9	MR
550	M.A.N. G 160	1749	78	0,5	19	MR
552	M.A.N. G 160	1749	92	0,5	19	MR
560A	ULTRA M.A.N. (RUBBER)	1750	30	5	0	R
579	ROLAND - ULTRA/M.A.N. ULTRA VII° G	1755	70	0,5	13	MR
636	MAN	1880	64	0,5	0	MR
529	ROLAND 900 XXL - 8 SPECIAL PLASTIC	1960	60	1	20	SP
529D	ROLAND 900 XXL SPECIAL PLASTIC	1960	50	1	20	SP
529B	ROLAND 900 XXL - 8	1960	60	0,5	20	MR
529A	ROLAND 900 XXL - 8 SPECIAL PLASTIC	1960	40	1	0	SP
529C	ROLAND 900 XXL - 8	1960	40	0,5	0	MR



# MANROLAND ROTATIVE - WEB - ROTATIVAS

CODICE CODE CODIGO	MACCHINA E MODELLO - MACHINE & MODEL - MÁQUINA Y MODELO	A	B	C	D	E
		MM	MM	MM		
620	OCTOMAN	743	55	0,5	12	MR
598	LITHOMAN III°	864	65	0,5	7	MR
589	MAN - UNISSET - PLAMAG CHROMOSET	1000	64	0,5	11	MR
605	LITHOMAN IV°	1020	65	0,5	8	MR
606	MAN CROMOMAN	1030	64	0,5	11	MR
579A	ROLAND - POLYMAN	1036	64	0,5	9	MR
615	POLYMAN/ROTOMAN (16 Pages)	1036	65	0,5	10	MR
588	ROTOMAN 8 (8 PAGES)	1036	65	0,5	10	MR
583	ROTOMAN - M	1040	65	0,5	10	MR
580	ROTOMAN	1040	65	0,5	6	MR
590	ROTOMAN	1060	65	0,5	9	MR
595	ROTOMAN (PLASTIC)	1060	68	1	9	P
591	ROTOMAN	1065	64	0,5	6	MR
592	LITHOMAN	1098	66	0,5	6	MR
581	LITHOMAN 1/5	1136	64	0,5	9	MR
625	COLORMAN	1330	65	0,5	7	MR
624	GEOMAN	1330	64	0,5	7	MR
599	LITHOMAN	1332	65	0,5	6	MR
600	LITHOMAN III° - 6/7 - MAN GEOMAN	1335	65	0,5	7	MR
582	COLORMAN	1340	65	0,5	7	MR
584	M.A.N. - E-LINE	1370	75	0,5	9+4	MR
565	COLORMAN	1400	65	0,5	14	MR
627	LITHOMAN	1467	50	0,5	13	MR
629	LITHOMAN	1468	65	0,5	12	MR
629A	M.A.N.	1468	64	0,5	9	MR
635	COLORMAN E-LINE	1470	76	0,5	9	MR
610	LITHOMAN	1477	90	0,5	16	MR
628	LITHOMAN	1516	65	0,5	13	MR
568	COLORMAN 35	1530	65	0,5	16	MR
569	M.A.N. GEOMAN	1530	65	0,5	8	MR
628A	LITHOMAN	1535	65	0,5	8	MR
574	M.A.N.	1590	64	0,5	10+4	MR
566	COLORMAN	1670	65	0,5	16	MR
566A	COLORMAN	1670	64	0,5	18	MR
626	UNIMAN	1760	65	0,5	9	MR
633	COLORMAN	1850	65	0,5	17	MR
636	M.A.N.	1880	64	0,5	0	MR
633A	LITHOMAN (64 Pages)	1980	65	0,5	10	MR
630	LITHOMAN	2060	65	0,5	11	MR
631	COLORMAN	2070	70	0,5	13	MR
634	COLORMAN	2080	65	0,5	0	MR
638	LITHOMAN	2135	65	0,5	13	MR
632	MAN - GEOMAN	2140	64	0,5	11	MR
637	COLORMAN	2170	64	0,5	13+5	MR
632A	COLORMAN XXXL	2230	64	0,5	12	MR

## EDELMANN (MANROLAND) FORM ALL - MODULO CONTINUO CONTINUOUS FORM - FORMULARIO CONTINUO

CODICE CODE CODIGO	MACCHINA E MODELLO - MACHINE & MODEL - MÁQUINA Y MODELO	A	B	C	D	E
		MM	MM	MM		
2645	JUNIOR PRINT	410	60	0,5	9	MR
2611	COMPUTER PRINT "V38"	412	62	0,5	5	MR
2615	FORM PRINT V38 (DRAWING - A)	415	60	0,5	9	MR
2616	FORM ALL	415	55	3	9	P
2610	PAK PRINT/WEB PRINT 39/JUNIOR/EXTREME V38	415	60	0,5	5	MR
2635	FORM PRINT 47	487	60	0,5	10	MR
2620	FORM PRINT SPECIAL	490	65	0,5	15	MR
2640	WEB PRINT 48 - FIVE	515	60	0,5	6	MR
2656	WEB 48	520	60	0,5	11	MR
2625	MINI PRINT	550	58	0,5	6	MR
2626	EVOPRINT	555	60	0,5	12	MR
2653	COLOR PRINT - V 52	572	58	0,5	6	MR
2630	VARIOPRINT 52	576	60	0,5	6	MR
2655	COLOR PRINT	774	58	0,5	8	MR
2650	WEB PRINT 39					



# RACLE SPECIALI - SPECIAL BLADES - REGLETAS ESPECIALES

## REALIZZAZIONE RACLE SPECIALI O PERSONALIZZATE

Qualsiasi racla non elencata nel presente catalogo potrà essere realizzata su specifica richiesta per un quantitativo minimo da convenire. Compilate questa scheda con tutti i dati ed inviatela per e-mail a: [pavan@pavanvr.com](mailto:pavan@pavanvr.com)

## MANUFACTURE OF SPECIAL OR PERSONALISED WASH-UP BLADES

Any blade not indicated in this catalogue can be made on specific request; the minimum order quantity is to be agreed. Please complete the form below with all the details and send it by e-mail to: [pavan@pavanvr.com](mailto:pavan@pavanvr.com)

## FABRICACION REGLETAS ESPECIALES O PERSONALIZADAS

Cualquier racla que no figure en el presente catálogo se podrá realizar, bajo pedido especial, por una cantidad mínima a convenir. Rellenar esta ficha con todos los datos y enviarla por e-mail a [pavan@pavanvr.com](mailto:pavan@pavanvr.com)

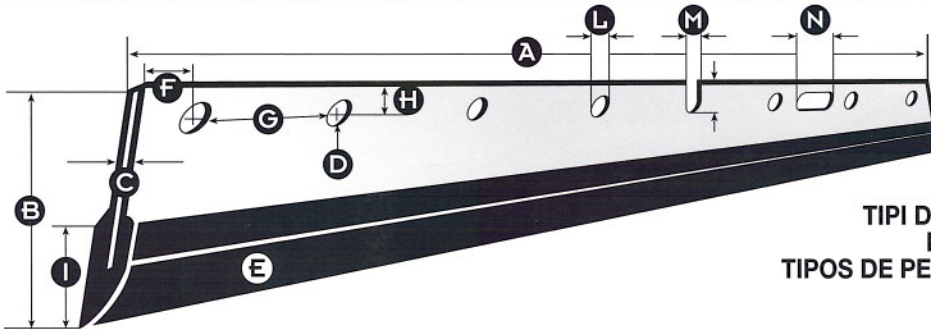

TIPI DI FORATURA  
HOLE TYPES  
TIPOS DE PERFORACION

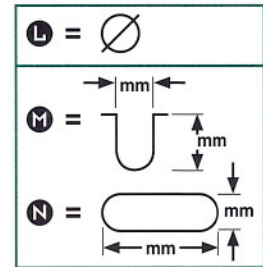

NOME DELLA MACCHINA E MODELLO	MACHINE NAME AND MODEL	NOMBRE DE LA MAQUINA Y MODELO
<p>N.B.: Per la buona riuscita dell'articolo si prega la gentile clientela di indicare esattamente le misure richieste in mm.</p> <p>N.B.: Please indicate the exact measurements in mm./inches to ensure the perfect reproduction of the blade</p> <p>N.B.: Para una perfecta produccion del articulo, se ruega a la gentil clientela de indicar exactamente las medidas solicitadas en mm.</p>		
LEGENDA	KEY	LLAVE DE LECTURA
<b>A = Lunghezza racla</b>	<b>A = Length of blade</b>	<b>A = Longitud regleta</b>
<b>B = Larghezza complessiva</b>	<b>B = Overall width</b>	<b>B = Ancho total</b>
<b>C = Spessore</b>	<b>C = Thickness</b>	<b>C = Espesor</b>
<b>D = Numero fori o asole</b>	<b>D = No. of holes or slots</b>	<b>D = N. de agujeros o muescas</b>
<b>E = Materiale</b>	<b>E = Material</b>	<b>E = Material</b>
MR = Metallo + gomma <input type="checkbox"/>	MR = Metal + rubber <input type="checkbox"/>	MR = Metal + goma <input type="checkbox"/>
MRE = Metallo + gomma EPDM <input type="checkbox"/>	MRE = Metal + rubber "EPDM" <input type="checkbox"/>	MRE = Metal + goma "EPDM" <input type="checkbox"/>
P = Plastica <input type="checkbox"/>	P = Plastic <input type="checkbox"/>	P = Plástico <input type="checkbox"/>
SP = Plastica speciale <input type="checkbox"/>	SP = Special plastic <input type="checkbox"/>	SP = Plástico especial <input type="checkbox"/>
R = Gomma <input type="checkbox"/>	R = Rubber <input type="checkbox"/>	R = Goma <input type="checkbox"/>
V = Vulcollan <input type="checkbox"/>	V = Vulcollan <input type="checkbox"/>	V = Vulcollan <input type="checkbox"/>
T = Teflon <input type="checkbox"/>	T = Teflon <input type="checkbox"/>	T = Teflón <input type="checkbox"/>
ST = Teflon sagomato <input type="checkbox"/>	ST = Shaped teflon <input type="checkbox"/>	ST = Teflon moldeado <input type="checkbox"/>
PVC <input type="checkbox"/>	PVC <input type="checkbox"/>	PVC <input type="checkbox"/>
FA = Fibra laminato + alluminio <input type="checkbox"/>	FA = Laminated fibre + aluminium <input type="checkbox"/>	FA = Fibra laminada + aluminio <input type="checkbox"/>
RA = Gomma + alluminio <input type="checkbox"/>	RA = Rubber + aluminium <input type="checkbox"/>	RA = Goma + aluminio <input type="checkbox"/>
MRA = Metallo + Gomma accoppiata <input type="checkbox"/>	MRA = Metal + Rubber coupled <input type="checkbox"/>	MRA = Metal + Goma acopiados <input type="checkbox"/>
F = Fibra laminata <input type="checkbox"/>	F = Laminated fibre <input type="checkbox"/>	F = Fibra laminada <input type="checkbox"/>
F = Distanza dallo spigolo al centro del primo foro	F = Distance from blade end to centre of first hole	F = Distancia del extremo al centro del primer agujero
G = Distanza dei fori (da centro a centro)	G = Hole spacing (centre to centre)	G = Distancia entre los agujeros (del centro al centro)
H = Distanza dal lato della racla al centro del foro	H = Distance from blade edge to centre of hole	H = Distancia del borde al centro del agujero
I = Altezza profilo in gomma	I = Rubber profile width	I = Ancho del perfil de goma
L = Diametro foro	L = Diametre of hole	L = Diámetro del agujero
M = Dimensioni asola	M = Sizes of slot	M = Dimensiones del las muescas
N = Dimensioni foro ovale	N = Sizes of oval hole	N = Dimensiones del agujero ovalado
"STANDARD" = Profilo in gomma "NBR" con durezza "STANDARD" a 95 shore (dura) <input type="checkbox"/>	"STANDARD" = Rubber profile "NBR" with 95 "STANDARD" shore (hard) <input type="checkbox"/>	"ESTANDAR" = Perfil de goma "NBR" con durezza "ESTANDAR" 95 shore (dura) <input type="checkbox"/>
"SOFT" = Profilo in gomma "NBR" con durezza "SPECIALE" a 85 shore (morbida) <input type="checkbox"/>	"SOFT" = Rubber profile "NBR" with 85 "SPECIAL" shore (soft) <input type="checkbox"/>	"SOFT" = Perfil de goma "NBR" con durezza "ESPECIAL" 85 shore (blanda) <input type="checkbox"/>
"UV" = Profilo in gomma "EPDM" con durezza 85 shore in presenza di macchine da stampa che utilizzano inchiostri "UV" <input type="checkbox"/>	"UV" = Rubber profile "EPDM" with 85 shore for "UV" ink printing machines <input type="checkbox"/>	"UV" = Perfil de goma "EPDM" con durezza 85 shore para máquinas que usan tintas "UV" <input type="checkbox"/>
<p>IMPORTANTE: Su specifica richiesta tutte le raclе lavarulli da noi prodotte possono essere fornite con lo speciale profilo in gomma "EPDM" avente durezza 85 shore necessario nei casi si presentino macchine da stampa che utilizzano inchiostri "UV"</p>	<p>IMPORTANT: On specific request, all the blades we manufacture can be supplied with special "EPDM" rubber profile with 85 shore, required for "UV" ink printing</p>	<p>IMPORTANTE: Bajo pedido especial, todas las regletas fabricadas por nosotros se pueden suministrar con el perfil en goma "EPDM" con durezza 85 shore, necesario para todas las máquinas que trabajan con tintas "UV"</p>





## ROLAND 200 / 300 / 500 / 700 / 900

### TRESU "D1" "D2" UNIVERSAL

MATERIALS AVAILABLE: FELT / FOAM / Rubber / Silicone

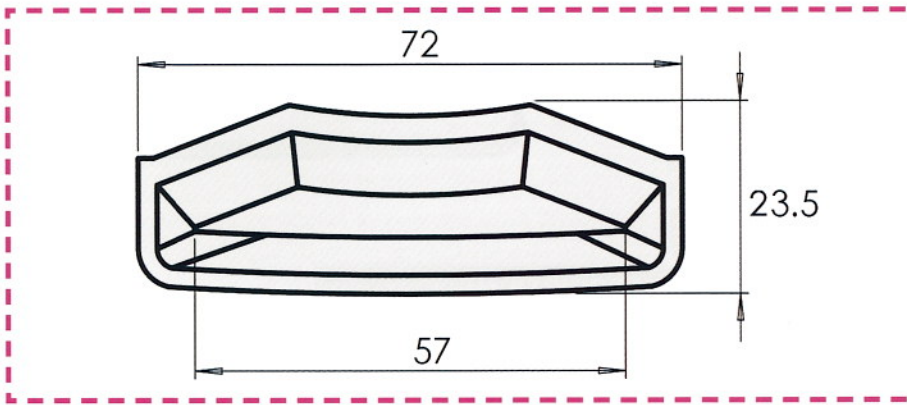

<b>MISURE REALI</b>
<b>REAL SIZES</b>
<b>MEDIDAS REALES</b>



Impregnated FELT code 18650-A



Rubber code 18650

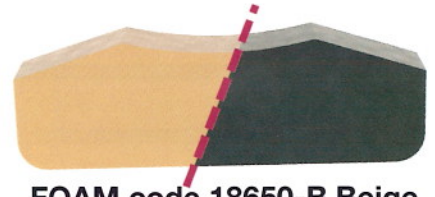

FOAM code 18650-B Beige  
FOAM code 18650-D Black

*confezione da 50 pz / packet of 50 pcs / confeccion de 50 pz*

## ROLAND 900 IV B / 900 V B / 900 VI B / 900 VII B / 900 VIII B

### TRESU "D4" UNIVERSAL

MATERIALS AVAILABLE: FELT / FOAM / Rubber

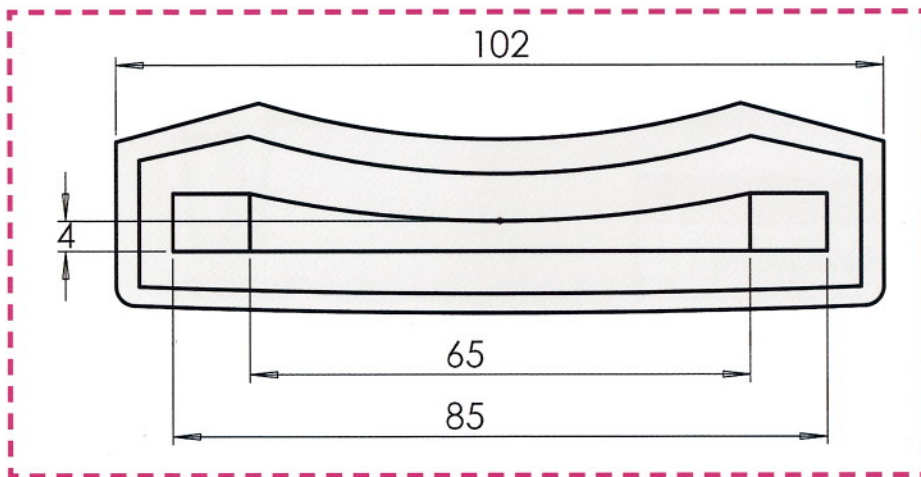

<b>MISURE REALI</b>
<b>REAL SIZES</b>
<b>MEDIDAS REALES</b>



Impregnated FELT code 18653-A



Rubber code 18653



FOAM code 18653-B Beige  
FOAM code 18653-C Black

*confezione da 50 pz / packet of 50 pcs / confeccion de 50 pz*



## BLOCKING CLIPS - MOLLE DI BLOCCAGGIO

CODE	DESCRIPTION
18651	BLOCKING CLIP D1 - D2 SMALL

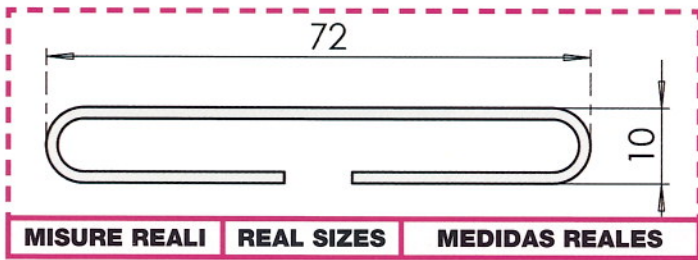

CODE	DESCRIPTION
18651A	BLOCKING CLIP D3 - D4 - D5 LARGE

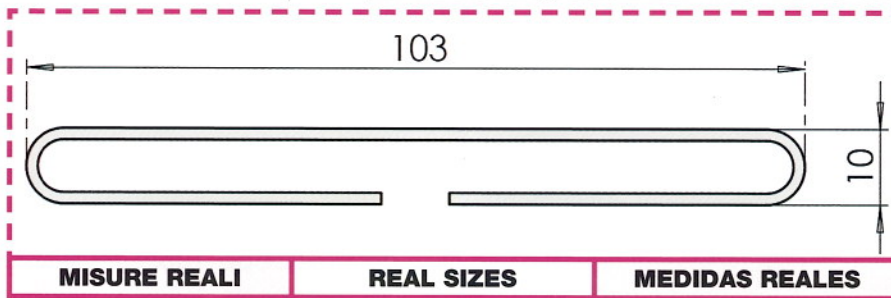

CODE	DESCRIPTION
18684	PINCER FOR SUPER COAT SEAL

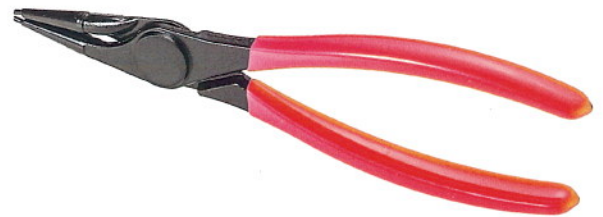

**NEW**

**SUPER GEL®**



CODE	DESCRIPTION
18686	SUPER GEL® (tube of 250 ml)

UNIVERSAL LUBRICATION FOR IMPREGNATED COAT SEALS - 250ML TUBE.

LUBRIFICANTE UNIVERSALE PER COAT SEALS - TUBETTO DA 250ML.

LUBRICANTE UNIVERSAL PARA COAT SEALS - TUBO 250ML.

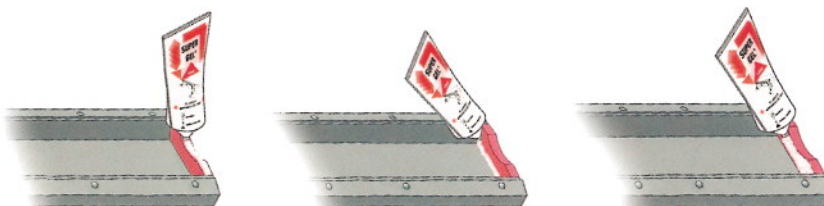

Correct lubrication of Coat Seals





# NEW SPECIAL ANILOX SPONGE®

CODE	DESCRIPTION
18645	SPECIAL ANILOX SPONGE

**SPECIAL SPONGE FOR OPTIMAL CLEANING OF THE ANILOX CYLINDER.**

**SPUGNA SPECIALE PER UNA PULIZIA OTTIMALE DEL CILINDRO ANILOX.**

**ESPONJA ESPECIAL PARA UNA LIMPIEZA ÓPTIMA DEL CILINDRO ANILOX.**

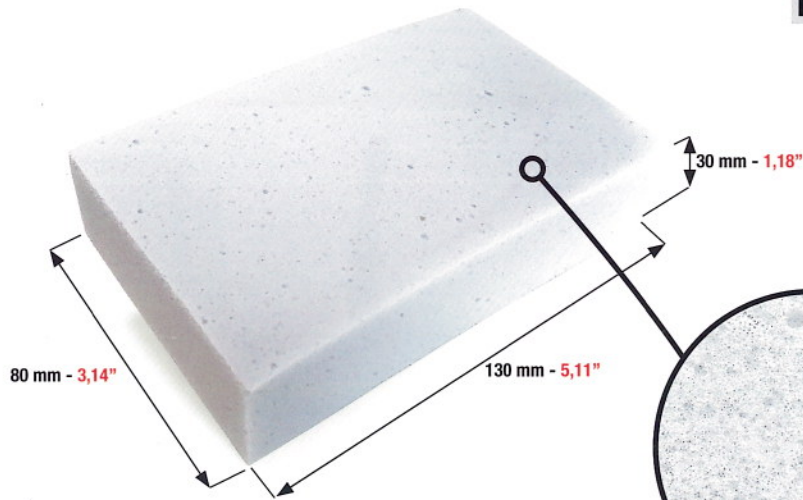

**SUPPLIED IN BOXES OF 50 PCS**

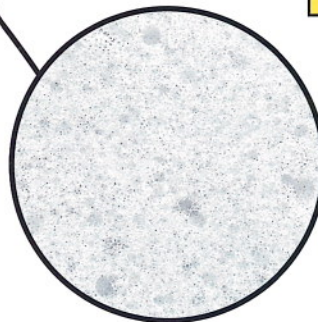

Special top quality material.  
Materiale speciale di altissima qualità.  
Material especial de primera calidad.

**PERFECT FOR EVERY ANILOX DESIGN - PERFETTO SU QUALSIASI TIPO DI ANILOX  
PERFECTO PARA CADA DISEÑO DE ANILOX**

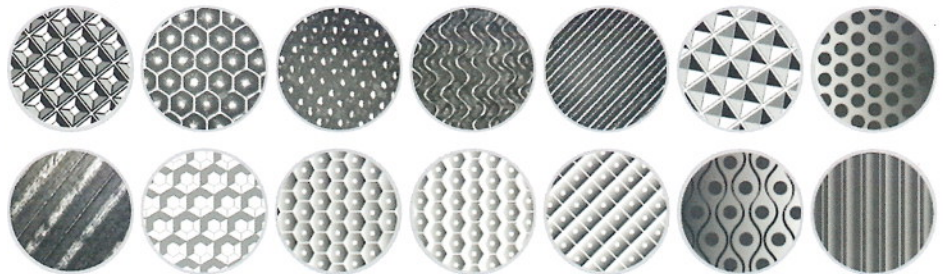

**REQUEST BY E-MAIL THE PRICE LIST RESERVED FOR YOU.  
RICHIEDETE PER E-MAIL IL LISTINO PREZZI A VOI RISERVATO.  
SOLICITE POR CORREO ELECTRONICO LA LISTA DE PRECIOS RESERVADA PARA USTED.**





# ROYAL CUTTER

FOR DOCTOR BLADES

The new Royal Cutter for Doctor Blades allows you to cut to any size in total freedom. Furthermore, to make it easier for you, we have created three versions with variable maximum extension.

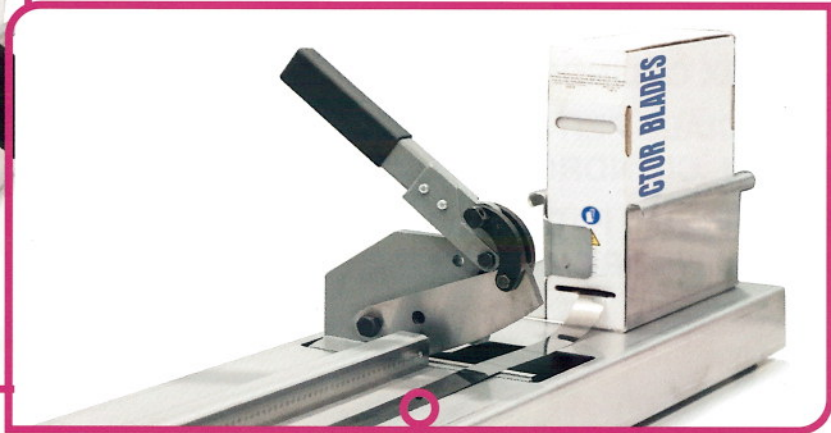

**NEW**

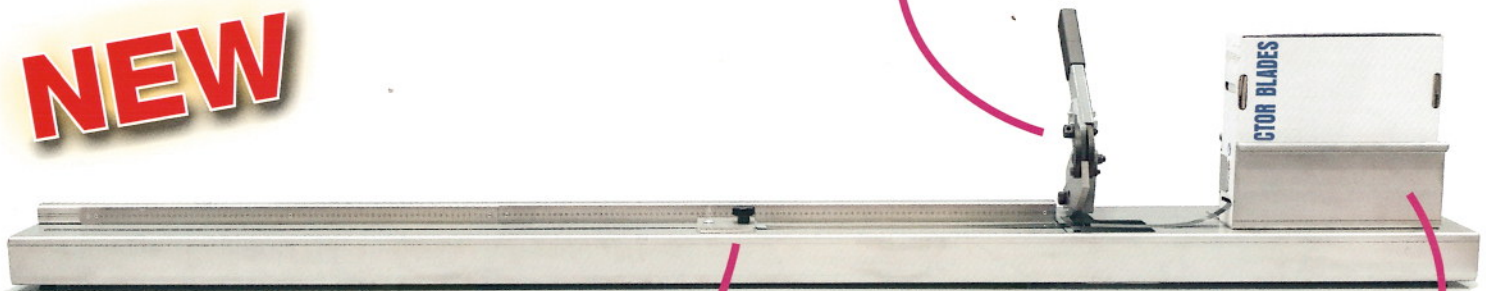

**THE WIDTH  
AND THE HEIGHT  
CAN BE REGULATED !!**

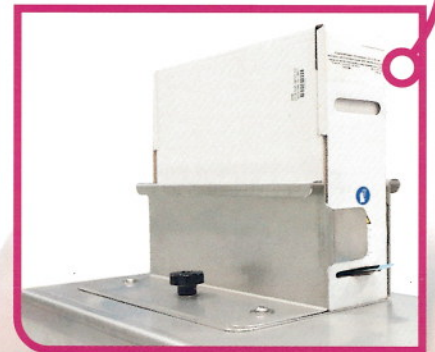

CODE	DESCRIPTION - SIZE
18740	ROYAL CUTTER SIZE 1300mm
18741	ROYAL CUTTER SIZE 1500mm
18742	ROYAL CUTTER SIZE 1700mm



**TOP QUALITY**



# SUPER DOCTOR BLADES

IN ACCIAIO - IN STEEL - EN ACERO

UNIVERSAL  
PRODUCT

PER VERNICI ACRILICHE A BASE DI ACQUA E VERNICI "UV"  
FOR ACRYLIC WATER BASED AND "UV" VARNISHES  
PARA BARNICES ACRILICOS BASE AGUA Y BARNICES "UV"

IN ROTOLO - IN ROLLS - EN ROLLOS

CODICE CODE CODIGO	MODELLO MACCHINA MACHINE MODEL MODELO DE MAQUINA	ALTEZZA / SPESSORE IN MM WIDTH / THICKNESS IN MM ANCHO / ESPESOR IN MM	FORNITO IN ROTOLO SUPPLIED IN ROLLS SUMINISTRADO IN ROLLOS	GRUPPO DI VERNICIATURA VARNISHING GROUP GRUPO DE BARNIZADO
18504-A	MANROLAND	35 MM X 0,20 MM	ROLL OF 100 MT.	<b>TRESU</b>

IN LUNGHEZZE PRE-TAGLIATE - IN PRE-CUT LENGTHS  
EN LONGITUD PRECORTADAS "TRESU"

CODICE CODE CODIGO	MODELLO MACCHINA MACHINE MODEL MODELO DE MAQUINA	ALTEZZA / SPESSORE IN MM WIDTH / THICKNESS IN MM ANCHO / ESPESOR IN MM	LUNGHEZZA IN MM LENGTH IN MM LONGITUD IN MM
18610	ROLAND 200/300/500	33 MM X 0,20 MM	788 MM
18614	ROLAND 700	35 MM X 0,20 MM	1090 MM
18616	ROLAND 900/4B	35 MM X 0,20 MM	1170 MM
18618	ROLAND 900/5B	35 MM X 0,20 MM	1350 MM
18620	ROLAND 900/6B	35 MM X 0,20 MM	1470 MM
18622	ROLAND 900/7B	35 MM X 0,20 MM	1674 MM
18624	ROLAND 900/8B	35 MM X 0,20 MM	1904 MM

# SUPER DOCTOR BLADES

IN PLASTICA - IN PLASTIC - EN PLASTICO

DISPONIBILI SU RICHIESTA - AVAILABLE ON REQUEST - DISPONIBLES POR PEDIDO

	 SECTION	 SECTION
CODICE CODE CODIGO	ALTEZZA / SPESSORE IN MM WIDTH / THICKNESS IN MM ANCHO / ESPESOR IN MM	LUNGHEZZA IN MT. LENGTH IN MT. LONGITUD IN MT.
18704A	28 MM X 0,35 MM	ROLL OF 100 MT.
18705A	32 MM X 0,35 MM	ROLL OF 100 MT.
18705B	35 MM X 0,35 MM	ROLL OF 100 MT.
18706A	38 MM X 0,35 MM	ROLL OF 100 MT.
18706B	40 MM X 0,35 MM	ROLL OF 100 MT.

**NEW**





# ROYAL TOP PLATE®

THE NUMBER ONE SINCE 1987



## HIGH QUALITY COATING PLATES

### SURFACE IN RESIN

- VERY EASY TO STRIP.
- 100% SPLITTING (COATING TRANSFER).
- NO INK BUILD-UP.
- SHARP AND CLEAN EDGES EVEN AFTER LONG PRINT RUNS.
- COMPATIBLE WITH ALL TYPES OF COATINGS: UV, WATER-BASED, GLOSSY, MATT, ETC..
- HIGH DIMENSIONAL STABILITY ALWAYS GUARANTEES A PERFECT REGISTER.
- AVAILABLE IN ANY SIZE.
- SPECS:

COLOUR	Blue	Blue
BI-DIRECTIONAL	Yes	Yes
CARRIER	Polyester	Polyester
NOMINAL THICKNESS MM Tolerance +/- 0,02mm	1,15mm	1,35mm
THICKNESS OF CARRIER	0,35mm	0,35mm
THICKNESS OF THERMOPLASTIC STRIPPING LAYER MM	0,80mm	1,00mm
COATING COMPATIBILITY	Water-based and UV	Water based and UV
ROUGHNESS (Ra:µm)	0,8 – 1,2 µm	0,8 – 1,2 µm
STRIPPING DEPTH MM	0,80mm	1,00mm
SURFACE HARDNESS (Shore A)	75°	75°

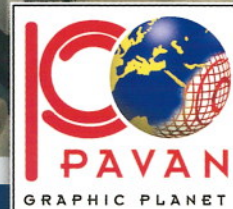



# ROYAL COAT COATING PLATES WITH RUBBER SURFACE

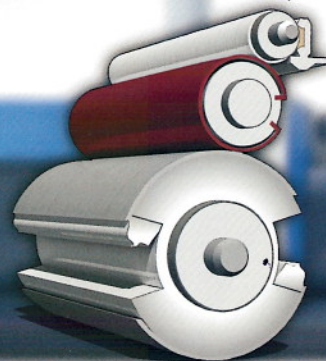

## ROYAL COAT

COLOUR	Blue	Blue	Blue
BI-DIRECTIONAL	Yes	Yes	Yes
CARRIER	Polyester	Polyester	Polyester
NOMINAL THICKNESS MM Tolerance +/- 0,02mm	1,15mm	1,35mm	1,95mm
THICKNESS OF CARRIER	0,35mm	0,35mm	0,35mm
COMPRESSIBLE layer	-	-	yes
THICKNESS OF COMPRESSIBLE LAYER MM	-	-	0,60
COATING COMPATIBILITY	aqueous + UV	aqueous + UV	aqueous + UV
ROUGHNESS (Ra:µm)	0,6 – 0,9 µm	0,6 – 0,9 µm	0,6 – 0,9 µm
STRIPPING DEPTH MM	0,80mm	1,00mm	1,00mm

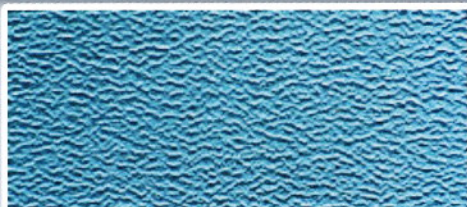

## ROYAL COAT PLUS "DUAL PURPOSE"

COLOUR	Grey	Grey	Grey
BI-DIRECTIONAL	Yes	Yes	Yes
CARRIER	Polyester	Polyester	Polyester
NOMINAL THICKNESS MM Tolerance +/- 0,02mm	1,15mm	1,35mm	1,95mm
THICKNESS OF CARRIER	0,35mm	0,35mm	0,35mm
COMPRESSIBLE layer	-	-	yes
THICKNESS OF COMPRESSIBLE LAYER MM	-	-	0,60
COATING COMPATIBILITY	aqueous + UV	aqueous + UV	aqueous + UV
ROUGHNESS (Ra:µm)	0,5 – 0,7 µm	0,5 – 0,7 µm	0,5 – 0,7 µm
STRIPPING DEPTH MM	0,80mm	1,00mm	1,00mm



## ROYAL COAT UV SPECTRA

COLOUR	Orange	Orange	Orange
BI-DIRECTIONAL	Yes	Yes	Yes
CARRIER	Polyester	Polyester	Polyester
NOMINAL THICKNESS MM Tolerance +/- 0,02mm	1,15mm	1,35mm	1,95mm
THICKNESS OF CARRIER	0,35mm	0,35mm	0,35mm
COMPRESSIBLE layer	-	-	yes
THICKNESS OF COMPRESSIBLE LAYER MM	-	-	0,60
COATING COMPATIBILITY	UV	UV	UV
ROUGHNESS (Ra:µm)	0,6 – 0,8 µm	0,6 – 0,8 µm	0,6 – 0,8 µm
STRIPPING DEPTH MM	0,80mm	1,00mm	1,00mm



## NEW ROYAL COAT GOLD

COLOUR	Yellow	Yellow	Yellow
BI-DIRECTIONAL	Yes	Yes	Yes
CARRIER	Polyester	Polyester	Polyester
NOMINAL THICKNESS MM Tolerance +/- 0,02mm	1,15mm	1,35mm	1,95mm
THICKNESS OF CARRIER	0,35mm	0,35mm	0,35mm
COMPRESSIBLE layer	-	-	yes
THICKNESS OF COMPRESSIBLE LAYER MM	-	-	0,60
COATING COMPATIBILITY	aqueous + UV	aqueous + UV	aqueous + UV
ROUGHNESS (Ra:µm)	0,5 – 0,7 µm	0,5 – 0,7 µm	0,5 – 0,7 µm
STRIPPING DEPTH MM	0,80mm	1,00mm	1,00mm

*The dawn of a new era for coating plates.*

## RSB ROYAL STRIP BLANKETS



COLOUR	BLUE
CONSTRUCTION	3 FABRIC LAYERS
COMPRESSIBLE LAYER	CLOSED CELLS
THICKNESS MM	1,95 ± 0,02 MM
HARDNESS ( TOTAL )	80° SHORE A
TENSILE STRENGTH	105 ( N/MM )
COMPRESSIBILITY	650 N/3 CM <sup>2</sup>
APPLICATION FIELDS	VARNISHING GROUP
IDENTIFICATION LINES	SINGLE LINE
INK COMPATIBILITY	70% ACRYLIC VARNISH, 30% UV VARNISH



ROYAL UNDER COAT

# ROYAL UNDER COAT®

UNDERPACKING SPECIFIC  
FOR COATING PLATES

Thicknesses  
mm.



## ROYAL UNDERCOAT NON ADHESIVE

- FABRIC
- FABRIC

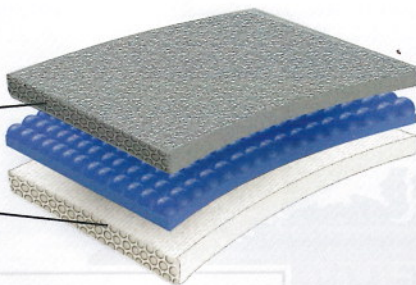

## ROYAL UNDERCOAT ADHESIVE

- FABRIC
- FABRIC
- ADHESIVE



## ROYAL UNDERCOAT ADHESIVE + POLYESTER

- FABRIC
- POLYESTER
- FABRIC
- ADHESIVE

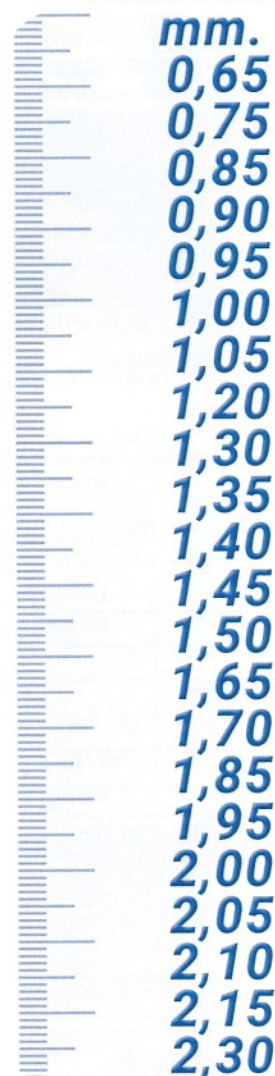
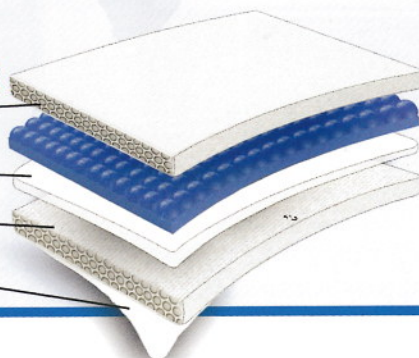

other thicknesses  
available on request

Surface: Fabric  
Tolerance +/- 0,01



FOGRA CERTIFICATION  
IN PREPARATION





TOP QUALITY

VERNICIATURA INDIRETTA - OFF-LINE COATING - BARNIZADO INDIRECTO

# SUPER COAT®

SPECIALE RIVESTIMENTO PLASTICO AUTOADESIVO PER VERNICIATURA INDIRETTA CON RISERVE

SPECIAL SELF-ADHESIVE PLASTIC MATERIAL FOR OFF-LINE SPOT COATING

REVESTIMIENTO PLASTICO ESPECIAL AUTOADHESIVO PARA BARNIZADO INDIRECTO CON RESERVA

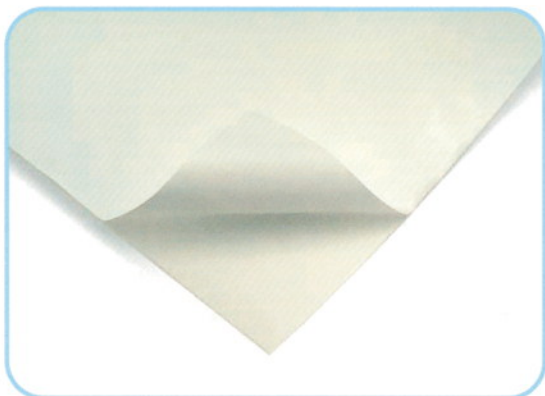

## SUPER COAT "PLUS"

SPESSORE THICKNESS ESPESOR		SEMITRASPARENTE SEMITRASPARENTE SEMITRASPARENTE		COLORE COLOUR COLOR
mm	inch.	adesivi		
0,53	0,021	x	x	neutro neutral

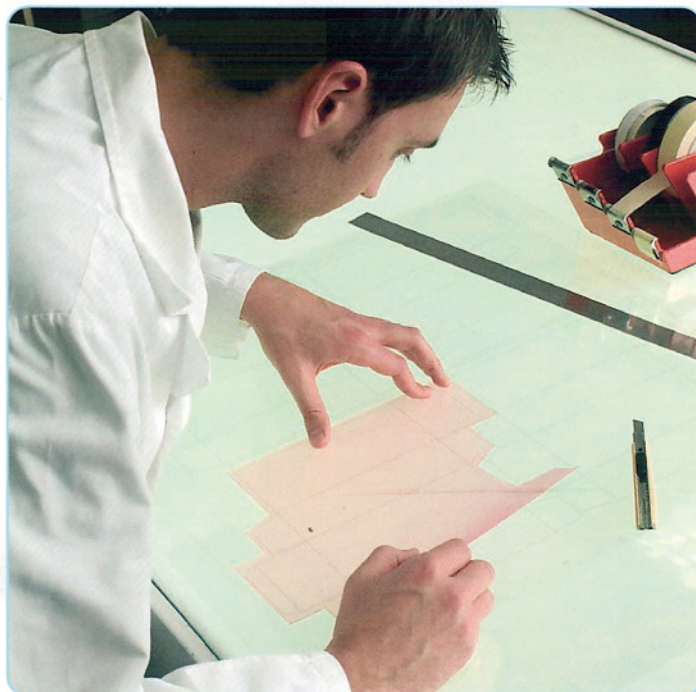

SUPER COAT PUÒ ESSERE FORNITO IN ROTOLO O IN QUALSIASI FORMATO RICHIESTO

SUPER COAT CAN BE SUPPLIED IN ROLLS OR IN ANY SIZE OF CUT SHEETS YOU WISH TO REQUEST

BAJO PEDIDO PODEMOS SUMINISTRAR EL SUPER COAT EN ROLLOS O CORTADO EN CUALQUIER FORMATO



# THE EVERLASTING CAN-OPENER!

CODE - CODICE - CODIGO

## 26.10419

\*MADE OF STEEL



# SUPERIOR MAGNIFYING GLASSES LENTINI E MICROSCOPI ILLUMINATI - MAGNIFYING GLASSES CUENTAHILOS Y MICROSCOPIOS ILLUMINADOS

**NEW**



**MASTER MAG**  
( 12x + LIGHT )

CODICE - CODE - CÓDIGO

**13536**

**NEW**

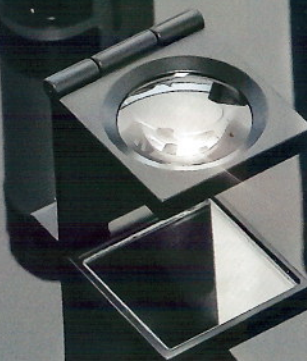

**ULTRA MAG**  
( 60x - 120x + LIGHT )

CODICE - CODE - CÓDIGO

**13533**

**NEW**

**SPACE MAG**  
( 10x + LIGHT )

CODICE - CODE - CÓDIGO

**13531**

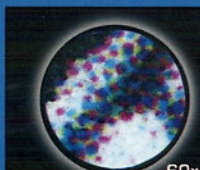

60x

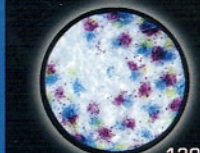

120x



**NEW**







CODICE CODE - CÓDIGO	MISURA SIZE - MEDIDA	INGRANDIMENTI ENLARGEMENTS - AUMENTOS
<b>13501</b>	<b>15x15</b>	<b>10</b>



CODICE CODE - CÓDIGO	MISURA SIZE - MEDIDA	INGRANDIMENTI ENLARGEMENTS - AUMENTOS
<b>13505</b>	<b>20x20</b>	<b>8</b>



CODICE CODE - CÓDIGO	MISURA SIZE - MEDIDA	INGRANDIMENTI ENLARGEMENTS - AUMENTOS
<b>13507</b>	<b>25x25</b>	<b>6</b>

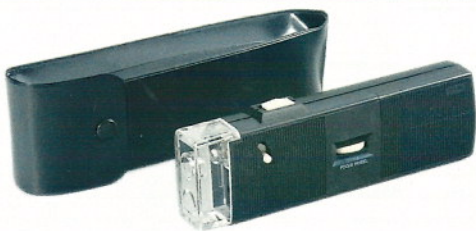

CODICE CODE - CÓDIGO	MICROSCOPIO ILLUMINATO MICROSCOPE WITH LIGHT MICROSCOPIO ILUMINADO	INGRANDIMENTI ENLARGEMENTS - AUMENTOS
<b>13525</b>		<b>50</b>



**PERSONALIZZABILE - CUSTOMIZABLE - PERSONALIZABLE**



CODICE CODE - CÓDIGO	MISURA SIZE - MEDIDA	INGRANDIMENTI ENLARGEMENTS - AUMENTOS
<b>13510</b>	<b>30x30</b>	<b>6</b>



**PERSONALIZZABILE - CUSTOMIZABLE - PERSONALIZABLE**



CODICE CODE - CÓDIGO	MISURA SIZE - MEDIDA	INGRANDIMENTI ENLARGEMENTS - AUMENTOS
<b>13530</b>	<b>-</b>	<b>10</b>

Questo kit rappresenta la massima espressione della praticità e dell'eleganza. Può essere fornito sia in forma "neutra" o su richiesta con il "logo" stampato ad un colore sul lentino (30x30) e impresso a caldo sulla custodia in cuoio.

This kit represents the maximum in practicality and elegance, it may be supplied in "neutral" form or, on specific request, with the "logo" printed in one colour on the magnifying glass (30x30) and heat-printed on the leather case.

Este kit representa la máxima expresión de lo práctico y de la elegancia. Se puede suministrar tanto de forma "neutra", como bajo pedido con el "logo" impreso a un color en el cuentahilos (30x30) e impreso por calor en el estuche de cuero.

CODICE CODE - CÓDIGO	MAGNIFYING GLASSES KIT	CUSTODIA + LENTINO CASE AND MAGNIFYING GLASS ESTUCHE Y CUENTAHILOS
<b>13535</b>		



# ROYAL MEASURING AND CONTROLLING INSTRUMENTS

STRUMENTI DI CONTROLLO E MISURAZIONE  
MEASURING AND CONTROLLING INSTRUMENTS  
INSTRUMENTOS DE CONTROL Y MEDIDA





# TOP UNIVERSAL INDIKATOR

SCALA DI MISURAZIONE "PH" DA 0 A 14 - "PH" MEASURING SCALE FROM 0 TO 14 - ESCALA DE MEDICION "PH" DE 0 A 14

 DA SEMPRE LE PIÙ SICURE, PRECISE E AFFIDABILI STRISCE PER LA MISURAZIONE DEL "pH" DELLE SOLUZIONI DI BAGNATURA

 ALWAYS THE SAFEST, MOST ACCURATE AND RELIABLE STRIPS FOR MEASURING THE "pH" LEVEL IN FOUNTAIN SOLUTIONS

 DESDE SIEMPRE LA MAS SEGURA, PRECISA Y FIABLE TIRA PARA LA MEDICION DEL "pH" EN LA SOLUCION DE MOJADO

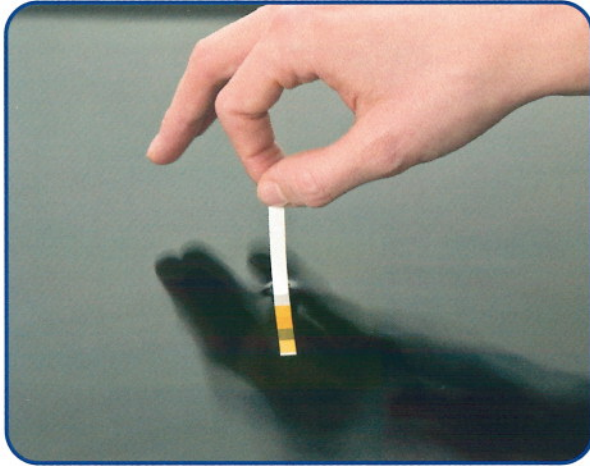

CODICE-CODE-CÓDIGO  
**272217**

CONFEZIONE IN PLASTICA CONTENENTE 100 STRISCE GRADUATE  
PLASTIC PACKET CONTAINING 100 GRADUATED STRIPS  
CONFECCION EN PLASTICO CONTENIENDO 100 TIRAS GRADUADAS

## TOP INDICATOR®

ALCOLOMETRO DI ALTA PRECISIONE - HIGH PRECISION ALCOHOLMETER  
ALCOHOLIMETRO DE ALTA PRECISION



 L'ALCOLOMETRO TOP INDICATOR® È LO STRUMENTO PIÙ ECONOMICO, PRECISO E FACILE DA UTILIZZARE INDISPENSABILE PER OGNI INDUSTRIA GRAFICA OGNI QUALVOLTA SI VOGLIA CONTROLLARE LA QUALITÀ DI ALCOOL ISOPROPILICO (IPA) NELLA SOLUZIONE DI BAGNATURA.

 THE ALCOHOLMETER TOP INDICATOR® IS THE MOST ECONOMICAL, MOST PRECISE AND EASIEST INSTRUMENT TO USE. NO PRINTING COMPANY SHOULD BE WITHOUT ONE WHENEVER THEY NEED TO CHECK THE AMOUNT OF ISOPROPILIC ALCOHOL (IPA) IN THE FOUNTAIN SOLUTION.

 EL ALCOHOLÍMETRO TOP INDICATOR® ES EL INSTRUMENTO MÁS ECONOMICO, PRECISO Y FACIL DE UTILIZAR, INDISPENSABLE PARA CADA INDUSTRIA GRAFICA PARA CADA VEZ QUE SE QUIERA CONTROLAR LA CALIDAD DEL ALCOHOL ISOPROPÍLICO (IPA) EN LA SOLUCIÓN DE MOJADO.





CODICE-CODE-CÓDIGO  
**2722400**





# TOP MICROMETER®

## SPECIALE MICROMETRO CON SUPERFICIE DI CONTATTO A DISCO - SPECIAL MICROMETER WITH DISC CONTACT SURFACE - MICRÓMETRO ESPECIAL CON SUPERFICIE DE CONTACTO DE DISCO

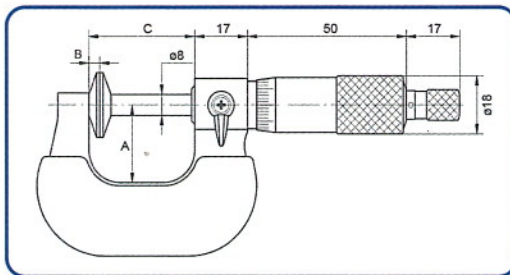
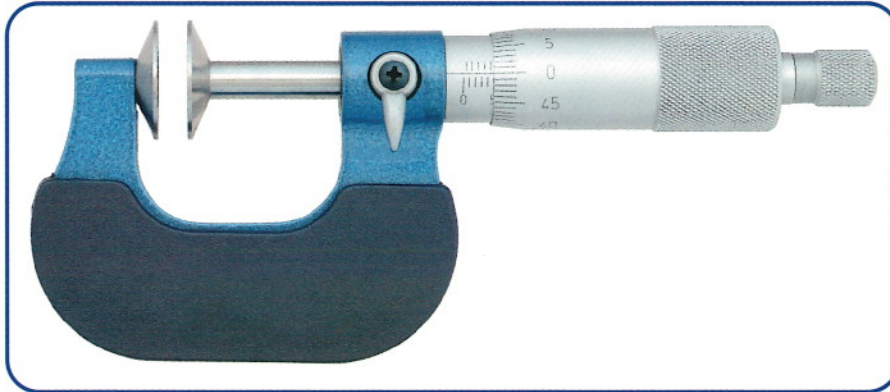

-  STRUMENTO DI ALTISSIMA PRECISIONE IN ACCIAIO FUCINATO VERNICIATO CON GUANCIALINI ISOLANTI. CAMPO DI MISURA 0.01 - 25MM. FORNITO COMPLETO DI ASTUCCIO, ASTA DI RISCONTRO (OLTRE I 25 MM), CHIAVE DI REGOLAZIONE.
-  VERY HIGH PRECISION INSTRUMENT IN PAINTED FORGED STEEL WITH INSULATING CHEEK PADS. MEASUREMENT RANGE 0,01 - 25 MM. SUPPLIED COMPLETE WITH CASE, CHECK ROD (OVER 25 MM), ADJUSTMENT KEY.
-  INSTRUMENTO DE MUY ALTA PRECISIÓN EN ACERO FORJADO PINTADO CON ALMOHADILLAS AISLANTES PARA LAS MEJILLAS. RANGO DE MEDIDA 0,01 - 25 MM. SE SUMINISTRA COMPLETO CON ESTUCHE, VARILLA DE RETENCIÓN (MÁS DE 25 MM), LLAVE DE AJUSTE.



CODICE-CODE-CÓDIGO  
**2722303**

# TOP DIGITAL CONTROLLER®

## SPECIALE MICROMETRO DIGITALE CON SUPERFICIE DI CONTATTO A DISCO SPECIAL DIGITAL MICROMETER WITH DISC CONTACT SURFACE MICRÓMETRO DIGITAL ESPECIAL CON SUPERFICIE DE CONTACTO DE DISCO

-  STRUMENTO DIGITALE DI ALTISSIMA PRECISIONE CON GUANCIALINI ISOLANTI. CAMPO DI MISURA 0.01 - 25MM. FORNITO COMPLETO DI ASTUCCIO E ASTA DI RISCONTRO (OLTRE I 25 MM).
-  VERY HIGH PRECISION DIGITAL INSTRUMENT WITH INSULATING CHEEK PADS. MEASUREMENT RANGE 0,01 - 25 MM. SUPPLIED COMPLETE WITH CASE AND CHECK ROD (OVER 25 MM).
-  INSTRUMENTO DIGITAL DE MUY ALTA PRECISIÓN CON ALMOHADILLAS AISLANTES PARA LAS MEJILLAS. RANGO DE MEDIDA 0,01 - 25 MM. SE SUMINISTRA COMPLETO CON ESTUCHE E VARILLA DE RETENCIÓN (MÁS DE 25 MM).





CODICE-CODE-CÓDIGO  
**2722304**



# TOP DIGITAL MICROMETER®

NUOVO MODELLO - NEW MODEL - NUEVO MODELO - NUOVO MODELLO - NEW MODEL - NUEVO MODELO

-  STRUMENTO DI ALTISSIMA PRECISIONE PER LA MISURAZIONE E LA CALIBRAZIONE DEGLI SPESSORI.
-  TOP QUALITY INSTRUMENT FOR THE MEASUREMENT AND GAUGING OF THE THICKNESSES.
-  INSTRUMENTO DE ALTÍSIMA PRECISIÓN PARA LA MEDIDA Y LA CALIBRACIÓN DE LOS GROSORES.

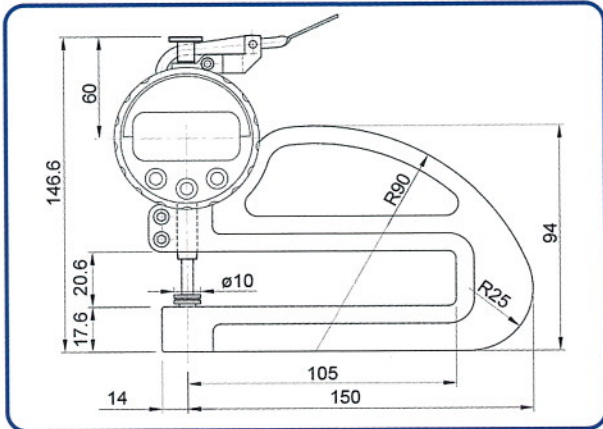

PROGETTATO PER OFFRIRE LA MASSIMA RIGIDITÀ E PRECISIONE.  
DESIGNED TO OFFER MAXIMUM RIGIDITY AND PRECISION.  
DISEÑADO PARA OFRECER LA MÁXIMA RIGIDEZ Y PRECISIÓN.





CODICE-CODE-CÓDIGO

**2722307**



## TENSION KIT

**KIT TENSIONATORE PER CAUCCIÙ  
TENSION KIT FOR BLANKETS  
KIT TENSIONADOR DE CAUCHOS**

-  IL KIT CHE GARANTISCE "SICUREZZA E QUALITÀ", IL KIT CHE OGNI INDUSTRIA GRAFICA DOVREBBE EQUIPAGGIARE IN DOTAZIONE ALLE PROPRIE MACCHINE DA STAMPA
-  THE KIT THAT GUARANTEES "RELIABILITY AND QUALITY", THE KIT THAT NO PRINT-SHOP SHOULD BE WITHOUT
-  EL KIT QUE GARANTIZA "SEGURIDAD Y CALIDAD", EL KIT CON EL QUE CADA INDUSTRIA GRAFICA DEBERIA ESTAR EQUIPADO, COMO DOTACION A LA PROPIA MAQUINA DE IMPRESION



CODICE-CODE-CÓDIGO

**2722580**



## PAPER SCALE

**BILANCIA PESA CARTA  
PAPER WEIGHING SCALE  
BÁSCULA DE PESAJE DE PAPEL**

-  BILANCIA PESA CARTA DA 0 A 350 GR./M2 - MADE IN GERMANY
-  PAPER WEIGHING SCALE FROM 0 TO 350 GR./M2 - MADE IN GERMANY
-  BÁSCULA DE PESAJE DE PAPEL DE 0 A 350 GR. /M2 - FABRICADA EN ALEMANIA

CODICE-CODE-CÓDIGO

**2831207**

